

NEW HOLLAND BOROUGH

**NEW HOLLAND BOROUGH
LANCASTER COUNTY
PENNSYLVANIA**

SPECIFICATIONS

FOR CONSTRUCTION OF

SANITARY SEWERS / WATER FACILITIES

June 2025

Prepared by:



**BECKER
ENGINEERING**

1848 Charter Lane | Suite 214
Lancaster, PA 17601

New Holland Borough
Lancaster County, Pennsylvania

Table Of Contents

<u>DESCRIPTION</u>	<u>SECTION</u>
Administrative Procedures.....	AP
Definitions and Special Conditions.....	SC
Provisions for Grease/Sand Interceptors.....	GT
Utility Easements.....	UE
Submittals.....	01300
Trench Excavation and Backfill.....	02201
Water Mains and Appurtenances.....	02665
Manholes.....	02730
Sanitary Sewer Pipe.....	02731
Force Mains.....	02732
Low Pressure Sanitary Sewer.....	02733
Packaged Individual Grinder Pump Stations.....	11309
Construction Details	

ADMINISTRATIVE PROCEDURES

ADMINISTRATIVE PROCEDURES

I. INTRODUCTION

The following Administrative Procedures and Standard Specifications for Construction of Sanitary Sewers/Water Facilities are in accordance with, and subject to Ordinance No. 581 and Resolution 490 (and subsequent amendments) as adopted by the New Holland Borough, hereinafter referred to as the Borough. A copy of this information is available for download online at <https://newhollandborough.org/>.

II. ADMINISTRATIVE PROCEDURES

A. APPLICATION FOR RESERVATION OF SANITARY SEWER / WATER CAPACITY

1. All developers of a subdivision or land development subject to a reserve capacity charge shall prepare and submit to the Borough, with their preliminary development plan, and in no event less than thirty (30) days prior to the date of the Borough's consideration of a plan as the final plan, a written application to the Borough requesting the allocation to and reservation of sanitary sewer and/or water capacity for the development.
2. The application for the reservation of such sanitary sewer capacity shall be in writing, including the current application form (available at the Borough office) and contain a time schedule for the development of the subdivision or land development, and include such other information and supporting data as the Authority shall determine is reasonably necessary to estimate a five (5) year sewage flow from the development.
3. The Authority shall, in its sole discretion, based upon competent engineering advice, and all other factors and conditions relating to the sanitary sewage and/or water system existing at the time of approval,

determine the sanitary sewer capacity and/or water capacity to be allocated to and reserved by the applicant for the development.

4. The Authority shall determine, based on the extent and complexity of the application, the necessary escrow required to process, review and inspect the proposed activity/connection. A separate agreement between the Authority and the applicant will be executed to detail the escrow requirement.
5. Capacity will not be granted or reserved until the escrow agreement has been completed and the necessary reservation and escrow fees paid.

B. APPLICATION PROCEDURE FOR EXTENSION AND/OR CONNECTION OF SANITARY SEWER SYSTEM AND/OR WATER SYSTEM

1. Any person or persons desiring extension and/or connection of the sanitary sewer/water facilities shall make preliminary application in writing to the Authority. This application shall be accompanied by the sufficient data and/or plans to allow the Authority to review and determine the extent to the proposed activity. All submissions shall include a minimum of three (3) sets of plans for review. The Authority will retain all three (3) sets of review plans. The required plans shall be in accordance with the Authority's Standard Specifications for Construction of Sanitary Sewers/Water Facilities. The application and supporting data shall be submitted prior to, or at the time the preliminary subdivision plan is submitted. The requesting party shall bear all costs incident to the application, design, review, construction and inspection of said extension and/or connection.
2. Coincident with the submission of the preliminary application an escrow amount (to be specified by the Borough) shall be submitted for reimbursement of (1) the Borough Engineer's cost in review of the plans, shop drawings, observation of the improvements and record

drawing review and, (2) the Borough Solicitor's cost in review of right-of-way plats and deeds and preparation of a developer's agreement, and (3) anticipated observation costs, if required. Should the actual costs of these services exceed the escrowed amount, the person(s) desiring the extension shall be liable for the additional costs and shall pay an additional escrow amount when and as determined by the Borough. Any unused portion of the escrowed amount will be returned to the applicant.

3. Upon receipt of the preliminary application and required supplemental data, the Borough will submit the same to the Borough Engineer for review and comment. Upon receipt of the Borough Engineer's recommendations, the Borough will review the preliminary application and advise the requesting party of the results of the review.
4. If the Borough permits the extension of the sewer system/water system, the Borough will recommend to the New Holland Borough Council submission of the Planning Module for Land Development to the local office of the Department of Environmental Protection (DEP) for review and approval.
5. If the DEP approves the Planning Module, a letter from the agency will be forwarded to the Borough informing of such approval and notifying whether or not an application for the DEP Water Quality Management extension permit will be required.
6. With regards to sewer extensions and/or connections, the applicant, upon the Borough's receipt of the DEP's approval of the Planning Module, will apply for the DEP extension permit (if necessary). After issuance of the permit (in the name of the New Holland Borough) by the DEP, the Borough will forward to the requesting party an agreement of the extension of the system.

7. A Sampling Plan shall be submitted to the Borough for review and approval prior to final plan approval for all non-residential customers. For sampling requirements, contact the Borough.
8. Internal plumbing plans shall be submitted to the Borough Engineer for review and approval prior to issuance of the building permit for all non-residential customers.
9. The Borough may, at its discretion, require the applicant to prepare and deposit, with the Borough, an improvement construction guarantee, which shall be computed as provided hereinafter, sufficient to cover the construction costs of the extension and/or connections to the water systems. If the improvements are to be subject to such improvement construction guarantee, the applicant shall be advised of the requirement at the time of submission of capacity application. Such guarantees shall be equal to one hundred ten percent (110%) of the costs as estimated by bonafide bids from contractors selected by the party posting security or, in the absence of such bids, an estimate prepared by a registered Pennsylvania Professional Engineer and reviewed/approved by the Borough Engineer. The following forms of guarantees shall be acceptable to the Borough provided, however, that the final form thereof shall be approved by the Borough's Solicitor:
 - a. A letter of credit provided by the developer from a Federal or Commonwealth chartered financial institution or other reputable institution.
 - b. A deposit of cash either with the Borough or in an escrow or restrictive account held in trust by a lending institution until released by the Borough.
10. The requesting party may then undertake the construction of the extension and/or connection in accordance with the Borough's Standard Specifications for Construction of Sanitary Sewers and

Water Facilities. The Borough Engineer or Resident Representative of the Borough will conduct periodic observations during the construction of the improvements as necessary.

11. The applicant posting security for improvement construction guarantee may request release of funds as improvements are completed. In such a case, the Borough may have the Borough Engineer report on the status of completion. The Borough shall release ninety percent (90%) of the estimated cost of partial improvements, retaining the remainder until final inspection and acceptance by the Borough.
12. Upon completion of construction, the requesting party shall immediately notify the Borough in writing by certified or registered mail of the completion of the improvements and shall send a copy to the Borough Engineer.
13. Upon completion of construction, and prior to dedication of the facilities to the Borough, the requesting party shall submit one set of record drawings to the Borough Engineer for review. After the Borough Engineer reviews and approves the submitted Record Drawings, two print sets, and two digital copies of the Record Drawings (1 CAD and 1 PDF) shall be submitted to the Borough. The Borough will not accept dedication of the facilities until the appropriate copies of the approved Record Drawings are submitted.
14. The Borough shall, within 10 days after receipt of such notification, direct the Borough Engineer or Resident Representative of the Borough to conduct a final inspection of the improvements. The Borough Engineer or Resident Representative of the Borough will, within 30 days of receipt of the Borough's above notification, file a report with the Borough concerning the findings of such final inspection.

15. The Borough may, at its discretion, require the applicant to submit a maintenance guarantee in order to guarantee the integrity and proper functioning of the improvements. If the improvements are to be subject to a maintenance guarantee, the applicant shall be advised of the requirement at the time of submission of the capacity request. Financial security shall not exceed fifteen percent (15%) of the installation costs of sanitary sewer and/or water facilities being dedicated to the Borough. The financial security shall be in one of the forms permitted in Paragraph 9 above and be subject to the approval of the Borough's Solicitor. The terms of a maintenance guarantee shall not exceed eighteen (18) months.
16. Immediately upon the recording of any applicable deeds of dedication and final approval and acceptance of ownership, all pipes, fittings, connections, and appurtenances located within rights-of-way or streets, along with the connections to the curb stop, shall become the property of the Borough. All permanent rights-of-way across private property shall be approved by the Borough's Solicitor and shall be a minimum of 30 feet width and shall be transferred to the Borough reciting all details and right to enter thereon for any purpose appropriate to the inspection, repair or maintenance of the Borough's sanitary sewers and/or water system.
17. All subsequent resolutions affecting water and/or sewer facilities owned by the Borough shall be binding upon the requesting party, their successor, heirs, assignees or agents.
18. Upon completion of the construction and acceptance by the Borough, the requesting party may apply for connection permits and shall be subject to all current rates and charges attendant to the facility.

DEFINITIONS AND SPECIAL CONDITIONS

DEFINITIONS AND SPECIAL CONDITIONS

I. GENERAL:

It is the intent of these Specifications to govern the Developer/Contractor in furnishing all labor and materials, and performing all work necessary for construction of extensions to the New Holland Borough sanitary sewer and water system.

II. DEFINITIONS:

"Application" shall mean a form available at the Borough office containing a checklist of plan requirements and other general information used for administrative purposes to aid in the review of the subdivision, land development plan, or improvements.

"Borough" shall mean the New Holland Borough, its agents (including New Holland Authority), or any person or persons authorized by the New Holland Borough to act on behalf of the New Holland Borough.

"Borough Engineer" shall mean the special or regular individual or entity appointed by and representing the Borough with respect to engineering matters described in these specifications.

"Contract" shall mean the written agreement executed by and between the developer and contractor, covering the performance of the work and the furnishing of labor, materials, and service in construction of improvements.

"Developer/Contractor" shall mean the party or parties constructing the sanitary sewer and/or water extension.

"Easement" shall mean a right-of-way granted for limited use of land for public, quasi-public, or private purpose.

"Inspection/Observation" shall mean the examination of the work performed by the contractor to ascertain its conformity with these specifications.

"Right-of-Way" shall mean a strip of land granted for public or private use.

"Public Sewerage System" shall mean a sewage disposal system and treatment facility complying with all the requirements and duly approved by the Department of Environmental Resources, and owned and operated by a municipality, municipal Borough, or public utility as defined and regulated by the Pennsylvania Public Utility Commission.

"Public Water Service" shall mean the supplying of safe, palatable, and potable water in sufficient quantities for the proposed potable use and not guaranteeing any specific quantity for use as fire protection. Said water to be supplied by, and only by, a municipality or municipal Borough.

"Solicitor" shall mean the special or regular individual or entity appointed by and representing the Borough with respect to legal matters described in these specifications.

III. BASIS OF DESIGN:

The design of all water system extensions or any other utility which shall cross the water system and/or any upgrades or improvements to the existing Authority water system shall be in accordance with these Specifications and the Pennsylvania Department of Environmental Protection Public Water Supply Manual.

The design of all sewer system extensions or any other utility which shall cross the sewer system and/or any upgrades or improvements to the existing Authority sewer system shall be in accordance with these Specifications and the Pennsylvania Department of Environmental Protection Domestic Wastewater Facilities Manual.

All sewer and water system extensions shall extend to the limits of the subject property being developed. Only one sanitary sewer or water lateral is permitted for each parcel.

The Developer/Contractor shall also comply with all applicable local, state, and federal requirements. All plans submitted to the Borough shall be sealed by a registered professional engineer licensed to practice in the Commonwealth of Pennsylvania, and shall be at a scale of 1" = 50' horizontal and 1" = 10' vertical. All sanitary sewer and water design plans shall be oriented so that the design plan view is located above the corresponding design profile for all sanitary sewer facilities.

IV. SPECIAL CONDITIONS:

The Borough reserves the right to make any corrections, additions, or deductions to these Specifications at any time without prior notification.

The Borough reserves the right to request additional work and/or materials, where, in its opinion, conditions warrant such work and materials.

Any design of facilities such as pumping stations, metering chambers, etc. which are not covered in these Specifications, shall be reviewed by the Borough on a case-by-case basis.

All existing sanitary sewer laterals connected to the Borough sanitary sewer system not being used shall be capped at the sanitary sewer main and the cap shall be encased in concrete.

All existing water service lines connected to the Borough water system not being used shall be disconnected at the water main and a Ford Abandoned Corporation Cap shall be installed.

V. INSURANCE:

CONTRACTOR'S LIABILITY INSURANCE

The limits of liability insurance shall provide coverage for not less than the following amounts or greater where required by laws and regulations:

Commercial General Liability:

1)	Each Occurrence:	\$1,000,000
2)	Damage to Rented Premises (Ea. Occurrence):	\$100,000
3)	Medical Expenses:	\$10,000
4)	Personal & Adv. Injury:	\$1,000,000
5)	General Aggregate:	\$2,000,000
6)	Products:	\$2,000,000

Automobile Liability:

1)	Combined Single Limit:	\$1,000,000
----	------------------------	-------------

Umbrella Liability:

1)	Each Occurrence:	\$1,000,000
----	------------------	-------------

Workers Compensation and Employer's Liability:

1)	Each Accident:	\$100,000
2)	Each Employee:	\$100,000
3)	Policy Limit:	\$500,000

CONTRACTOR's Liability Insurance Policies shall name the New Holland Borough, New Holland Borough Authority, Borough Engineer, Borough Solicitor, as additional insured parties.

PROPERTY INSURANCE

CONTRACTOR shall purchase and maintain until final payment property insurance upon the Work at the site to the full insurable value thereof (subject to such deductible amounts as may be provided in these Special Conditions or required by laws and regulations). This insurance shall include the interests of the Borough, New Holland Borough Authority, Contractor, Subcontractors, Borough Engineer, Solicitor and Borough Engineer's Consultants in the work (all of whom shall be listed as insured or additional insured parties). This insurance shall insure against the perils of fire and extended coverage, shall include "all-risk" insurance for physical loss and damage including theft, vandalism and malicious mischief, collapse and water damage, and such other perils as may be provided in these Special Conditions, and shall include damages, losses and expenses arising out of or resulting from any insured loss or incurred in the repair or replacement of any insured property (including but not limited to fees and charges of engineers, architects, attorneys and other professionals). If not covered under the "all-risk" insurance or otherwise provided in these Special Conditions, Contractor shall purchase and maintain similar property insurance on portions of the Work stored on and off the site or in transit.

DEDUCTIBLES

The maximum deductible amount for all property insurance to be provided by Contractor as required for this contract shall be \$10,000 or such limit as may be acceptable to the Borough. Approval of a deductible limit higher than \$10,000 shall be requested in writing and shall be accompanied by a copy of the insurance policy.

SPECIAL INSURANCE

Contractor shall, at its discretion, purchase any special property insurance as necessary and such additional coverage may be a part of the required property insurance policy.

ACCEPTANCE OF INSURANCE

If the Borough has any objection to the coverage afforded by or other provisions of the insurance required to be purchased and maintained by Contractor, the Borough shall notify Contractor in writing thereof within ten (10) days of the date of delivery of such certificates. Contractor shall provide to the Borough such additional information in respect to insurance provided as the Borough may reasonably request. Failure by the Borough to give any such notice of objection within the time provided shall constitute acceptance of such insurance purchased by the Contractor.

At the request of the Borough, Contractor shall provide a copy of the insurance policy under which the coverage for the contract is provided.

The Borough shall review insurance coverage or will assign, at its discretion, a qualified party to review all insurance coverages to be provided. Upon completion of review, Contractor and Contractor's property insurer or insurers may be required to sign an Insured Claim Waiver, or Contractor, if required, shall secure similar signatures on such forms from all subcontractors and their property insurers.

The Borough Engineer shall have no responsibilities regarding the advising, requiring, or obtaining of any form of insurance.

INSURANCE COMPANY RATING

All Property and Liability Insurance to be purchased by Contractor shall be placed with insurance companies which carry a rating of A- or better from A.M. Best and Company Insurance Rating Service and are admitted to do business in the Commonwealth of Pennsylvania.

PROVISIONS FOR GREASE/SAND INTERCEPTORS

PROVISIONS FOR GREASE/SAND INTERCEPTORS

A sand and/or grease interceptor shall be installed in a building sewer and/or wastewater drainage system whenever, in the opinion of the Authority, a hazard may exist from the careless disposal of waste material containing oils, fats, grease, sand, grit, heavy settleable solids and other flammable and deleterious materials.

A grease interceptor shall be installed in the building sewer of the following establishments: automobile service and repair facilities, garages where vehicles are washed or gasoline stored, dry cleaners using flammable solvents, aniline plants, tanneries, paint and varnish manufacturing plants, printing ink plants, shoe-polish plants, explosive plants, soap plants, cleaning fluid manufacturing plants, testing laboratories or any place of manufacture where volatile flammable liquid is used and which by accident or otherwise may be admitted into the drainage system.

A grease interceptor shall be installed in the waste line leading from sinks, drains or other fixtures in the following establishments: restaurants, hotel kitchens or bars, factory cafeterias or restaurants, clubs or other establishments with food preparation or kitchen facilities where oils, grease and fats may be introduced into drainage systems in quantities that may cause buildup in the lines, line stoppage or otherwise hinder or have an adverse affect on efficient sewage disposal. (Under sink grease traps do not qualify as final grease treatment).

The Authority, in addition to the other powers set forth in this Specification, shall have the authority to exempt from the requirements of this ordinance, existing establishments which now contain a functioning grease and/or sand interceptor which, after inspection, the Authority determines are being effectively maintained and operated so as to prevent fats, grease, oils, sands, grit or heavy settleable solids from being deposited into the sewer system of New Holland Borough Authority. Said exemption shall apply for only so long as the Authority determines that said existing facilities are functioning properly and are being properly maintained and cleaned. The Authority shall have the authority to require any owner to present a written certificate or other evidence acceptable to the Authority of regular periodic cleaning of the system if the Authority, in the Authority's discretion, deems that a problem may exist. All facilities operating grease interceptors shall provide proof of

cleaning and inspection at a frequency of 1 per 12 months at a minimum, and more if regular cleanings are required. The scheduled cleanings shall be coordinated with the Authority.

Sand interceptors shall be installed in addition to grease interceptors in any of the establishments referenced in the immediately preceding Section that also discharge into the sewerage system, liquid wastes containing sand, grit or heavy settleable solids.

Grease interceptor sizing calculations shall be submitted to the Authority Engineer as part of the Final Plan Review process and must be approved by the Authority prior to final plan approval. The criteria below shall be used to determine the appropriate size of the proposed grease interceptor.

A grease interceptor shall consist of one of the following:

- (1) a three-stage grease interceptor consisting of three separate tanks or one or more tanks divided into three segments by grease trapping baffles;
- (2) a three-stage manufactured/engineered grease interceptor consisting of a double baffled three (3) compartment unit installed in containment vaults with flow valves and vent lines as recommended by the manufacturer; or
- (3) a multi-stage grease interceptor of a configuration (baffles or piping) and orientation to comply with the requirements of this specification, sized to match the needs of the discharge being permitted.

A sand interceptor shall consist of one of the following:

- (1) a single or multi-stage interceptor baffled or fitted with flow directing vents and having suitable solid storage for adequate containment between cleaning;
- (2) a manufactured/engineered sand interceptor installed as per the manufacturer's recommendations.

The size and capacity of three stage grease interceptors shall be in accordance with the following criteria and the formula requiring the largest size shall be used:

- (1) Six gallons of capacity per stage, for every restaurant seat.
- (2) Three gallons per food customer served per peak day of operation, or anticipated peak day of operation in the case of a new business.
- (3) Such size as is sufficient to allow a minimum of one hour of detention of flow at the maximum flow rate generated at any time.

Manufactured/engineered grease interceptors shall be sized in accordance with the previous sizing requirements, or in accordance with the manufacturer's recommendations, whichever produces the larger tank.

All grease and sand interceptors shall be constructed of impervious materials capable of withstanding abrupt and extreme changes in temperature. The interceptors shall be of substantial construction, water-tight and equipped with easily removable covers. The interceptor's outlet shall be oversized or vented to prevent siphonage of tank contents.

All drawings, sketches, catalog information showing location, dimensional sizes, distances and construction materials and any other pertinent information, along with sizing calculations of all proposed interceptors, must be submitted to the Authority for its review and approval before any interceptor may be installed.

All owners who are required under this Specification to install sand and/or grease interceptors shall be totally responsible for the maintenance, upkeep, repair, replacement and operation of said interceptor(s) and shall keep the same in good operation and repair and shall be responsible or liable for any loss or damage occurring from any failure to operate, maintain and replace when needed, said interceptor(s).

A vent and trap shall be installed in the building sewer lateral between the building and the interceptor. A cleanout/test tee shall be installed in the lateral between the building sewer interceptor and sewer system main.

UTILITY EASEMENTS

UTILITY EASEMENTS

I. GENERAL

1. Easements shall be required for all sewer and/or water facilities intended for dedication to the Authority that are constructed outside the limits of a public street right-of-way. This includes, without limitation, sewer and/or water facilities installed within private streets and yard areas. In addition, easements may be required for sewer and/or water facilities constructed within a public street right-of-way if the existing right-of-way does not provide sufficient room for access or maintenance of the sewer and/or water facility.
2. Easements shall be a minimum of 30 feet wide and shall be, in general, centered over the sewer and/or water facilities unless otherwise approved by the Authority. Additional easement width may be required by the Authority on a case-by-case basis. Easements shall be for the exclusive use of sanitary sewer and/or water facilities owned or proposed to be dedicated to the New Holland Borough Authority. All other utilities shall remain outside the limits of the Authority's easement unless otherwise specifically approved by the Authority.
3. The Authority and its agents, contractors, or employees shall have free ingress, egress and regress on, over and through the easement at all times and seasons, with reasonable prior notice except in the case of an emergency, in order to inspect, monitor, maintain, reconstruct, enlarge, repair, remove, relocate, or related functions any sewer and/or water main or mains, manholes, connection fittings or other appurtenances as the Authority deems necessary in its sole discretion.
4. No building, fence, lighting fixture, pond, swimming pool, driveway, parking lot or other permanent structure shall be erected or located within the sewer and/or water easement. No vehicles, campers, trailers, boats or other large equipment or facilities shall be stored within the easement on a long-term basis. No trees, shrubbery or bushes shall be planted within the boundaries of the easement. In the event that the Authority is not able to access the easement due to any of the foregoing, the Authority shall have the right, but not the obligation, to remove such obstruction at the owner's expense.
5. Property owners shall not be due compensation from the Authority for damage to permanent structures, vehicles, or other large equipment, or loss of trees, shrubbery or bushes resulting from work performed by the Authority and its agents, contractors or employees that occurs to such items that are placed within the easement following execution of an access/easement agreement.
6. Property owners shall not alter the grade or construct landscaping features within the easement that would impair access by the Authority.

II. REQUIREMENTS FOR DEVELOPERS/EXTENDORS

1. Individual plot plans (exhibits) and legal descriptions shall be provided for all easements.
 - a. When an easement crossing multiple parcels is proposed by a developer, a single plot plan (at a legible scale) and legal description shall be acceptable only if the developer owns all parcels impacted by the easement at the time when the easement is offered for dedication. Otherwise, individual plot plans and legal description shall be required for all parcels containing a portion of the easement.
 - b. The developer, at its sole cost and expense, shall be responsible for securing all easements from private property owners when facilities are constructed across private property to serve the developer's property. Those easements shall be assigned to the Authority following review and approval of Record Drawings and prior to dedication of the newly constructed sewer and/or water facilities.
 - c. The developer, at its sole cost and expense, shall provide evidence that proposed sewer and/or water easements are incorporated into the deeds for individual properties within the development.
2. Dedication of easements shall occur following review and approval of Record Drawings and prior to dedication of the newly constructed sewer and/or water facilities.

SECTION 01300

SUBMITTALS

SECTION 01300 - SUBMITTALS

PART 1 - GENERAL

1.1 SUBMITTAL PROCEDURES:

- A. All submittals shall be delivered to the Borough at the New Holland Borough Office. An electronic copy of the submittal shall be provided to the Borough.
- B. Each transmittal shall be numbered in sequence. Identify project, street address, contractor, subcontractor, major supplier; identify any and all deviations from Borough Specifications. Provide space for Contractor and Borough Engineer review stamps.
- C. Submit three (3) copies of drawings not larger than 24" X 36" and drawn to a scale no smaller than fifty (50) feet to the inch. Scale shall be clearly noted on the drawings. An electronic copy of the submittal shall be provided to the Borough.
- D. All drawings showing water and/or sewer plans and profiles shall be oriented so that the plan view is located above the corresponding profile on the same drawing sheet.
- E. Stationing for sanitary sewer/water mains shall be from the centerline of the road.
- F. Apply Contractor's stamp, signed and dated certifying that review, verification of products required, field dimensions adjacent to construction work, and coordination of information is in accordance with the requirements of the work and Borough Specifications.
- G. Comply with progress schedule for submittals related to work progress. Coordinate submittal of related items.
- H. After Borough Engineer's review of submittal, revise and resubmit as required, identifying changes made since previous submittal.
- I. Distribute copies of reviewed submittals to concerned persons. Instruct recipients to promptly report any inability to comply with provisions.
- J. Upon completion of construction, and prior to dedication of the facilities to the Borough, the requesting party shall submit one set of record drawings to the Borough Engineer for review. After the Borough Engineer reviews and approves the submitted Record Drawings, two print sets and two digital copies of the Record Drawings (1 CAD and 1 PDF) shall be submitted to the Borough. The Borough will not accept dedication of the facilities until the appropriate copies of the approved Record Drawings are submitted.
- K. Provide Manufacturer's Safety Data Sheets (MSDS) for all products and materials.

1.2 CONSTRUCTION PROGRESS SCHEDULES:

- A. Submit initial progress schedules and schedule of values in duplicate along with the initial shop drawing submittal. After review by Borough Engineer, revise and resubmit as required. Submit revised schedules on a monthly basis, reflecting changes since previous submittal. Show projected percentage of completion for each item of work.
- B. Show submittal dates required for shop drawings, product data and samples, and product delivery dates.

1.3 SCHEDULE OF WORK:

- A. Submit typed schedule on 8-1/2" x 11" paper; Contractor's standard form or media-driven printout will be considered on request.
- B. Format: The Table of Contents of this document. Identify each line item with number and title of the major specification sections.

1.4 SHOP DRAWINGS:

- A. When required, five (5) copies of the shop drawings shall be submitted by the Contractor with such promptness as to avoid delay in the work. Emailed shop drawings is acceptable. After review of these drawings by the Borough Engineer, the shop drawings will be stamped: 1) "Reviewed"; 2) "Furnish as Corrected"; 3) "Revise and Resubmit"; 4) "Rejected"; 5) "Not Required for Review". If the shop drawings are stamped "Revise and Resubmit", the Contractor shall make the required correction and resubmit five copies of the corrected shop drawings to the Borough, and such other copies as may be needed for proper prosecution of the work. If the shop drawings are "Rejected", the Contractor shall prepare a new shop drawing submission. The Borough Engineer's review of shop drawings shall not relieve the Contractor from responsibility for errors or discrepancies in such drawings. All shop drawings shall be identified with the name of the Contractor, and numbered in consecutive order. Two copies of all shop drawings shall be retained by the Borough Engineer. One additional copy shall be retained by the Borough. E-mailed pdf file submittals will be accepted as long as the submittals are not larger than 11 x 17 and do not exceed twenty (20) pages. If large submissions are required, the Contractor shall provide five (5) copies to the Borough Engineer for review. All shop drawings shall be reviewed by the contractor prior to submission to the Borough Engineer. All submittals shall be stamped and signed by the Contractor noting the submittal meets the Borough Specifications for Construction of Sanitary Sewers / Water Facilities.

1.5 PRODUCT DATA:

- A. Mark each copy to identify applicable products, models, options and other data; supplement manufacturers' standard data to provide information unique to this project.

1.6 SAMPLES:

- A. Submit full range of manufacturers' standard colors, textures and patterns for Borough's selection. Allow four weeks for selection of finishes from time of submission.
- B. Submit samples to illustrate functional characteristics of the product, with integral parts and attachment devices. Coordinate submittal of different categories for interfacing work.
- C. Include identification on each sample with full project information.
- D. Submit the number of samples specified in respective specification section; one will be retained by the Borough. Review samples which may be used in the work are indicated in the specification section.

1.7 FIELD SAMPLES:

- A. Provide field samples of finishes at project as required by individual specifications section. Install sample complete and finished. Acceptable samples in place may be retained in completed work.

1.8 MANUFACTURERS' INSTRUCTIONS:

- A. When required in individual specification sections, submit manufacturers' printed instructions for delivery, storage, assembly, installation start up, adjusting and finishing in quantities specified for product data. In addition, operation and maintenance manuals shall be submitted at the end of the project.
- B. Identify conflicts between manufacturers' instructions and Borough Specifications.

PART 2 - MATERIALS

Not used.

PART 3 - CONSTRUCTION

Not used.

END OF SECTION

G:\BEng-Data\Projects\17-188-01\Specifications\Water\06-01300.doc

SECTION 02201

TRENCH EXCAVATION AND BACKFILL

SECTION 02201 - TRENCH EXCAVATION AND BACKFILL

PART 1 - GENERAL

1.1 RELATED SECTIONS:

Section 02665 - Water Mains and Appurtenances
Section 02730 - Manholes
Section 02731 - Sanitary Sewer Pipe
Section 02732 - Force Mains
Section 02733 - Low Pressure Sanitary Sewer

1.2 DESCRIPTION OF WORK:

- A. The work within this section includes, but is not limited to, the furnishing of all equipment, labor and materials and performing all operations necessary to excavate, protect and backfill all trenches in accordance with the Borough Specifications.
- B. The Contractor shall perform all excavation of every description and of whatever substance encountered to the depths required, as specified herein. In performing the work as specified in this section, the Contractor shall conform to the current regulations of the Pennsylvania Department of Labor and Industry and applicable Federal Regulations for Excavations and Construction. All excavated materials not required for backfill shall be removed and wasted or otherwise disposed of as required or specified.
- C. At the Authority's discretion, the Contractor shall allow 30 days of settlement for all trenches prior to final restoration. Final restoration shall be in accordance with the appropriate specification sections and details.

1.3 QUALITY ASSURANCE:

- A. Referenced standards shall be the following:
 - 1) Pennsylvania Department of Transportation (PennDOT) Publication 408 Specifications and its revisions.
 - 2) Pennsylvania Department of Transportation (PennDOT) Publication 213.
 - 3) American Society for Testing and Materials (ASTM).

PART 2 - MATERIALS

2.1 CLASSIFICATION OF MATERIALS:

- A. Trench Backfill (All Paved Areas) - This material shall consist of 2A coarse aggregate free of slag. All materials shall conform to PennDOT Publication 408, Section 703.3.

- B. Pipe Bedding and Initial Backfill - This material shall consist of No. 8 coarse aggregate free of slag, except in wet or unstable areas where the bedding shall be No. 57 coarse aggregate. All materials shall conform to PennDOT Publication 408, Section 703.3.
- C. Suitable Backfill (Non-Paved Areas) - This material shall consist of excavated material free from cinders, ashes, refuse, vegetable or organic material, boulders, rocks no larger than four (4) inches in dimension, stone or other material which in the opinion of the Borough is unsuitable.

PART 3- CONSTRUCTION

3.1 REMOVAL AND PROTECTION OF PAVEMENT:

- A. The Contractor shall clear the surface and remove all surface materials, of whatever nature, over the line of the trench; and shall properly separate and classify the material removed; and store, guard and preserve said material as may be required for use in backfilling, resurfacing, repaving or for other purposes. All rock, earth, sand, curbing, gutter and flagstones, and all sectional paving units which may be removed, together with all materials taken from the trenches, shall be stored in such parts of the street or roadway, or such other suitable place, and in such manner as accepted by the Borough. The Contractor shall be responsible for any loss of or any damage to paving materials through their own or their employee's careless removal or neglectful or waste storage, disposal or use of same.
- B. Pavement shall be cut to neat lines equidistant from the centerline of the trench and the edges of the pavement shall be protected and maintained by the Contractor until the repaving is completed. If the pavement edges are not maintained to the satisfaction of the Borough the pavement shall be saw cut prior to placing the pavement. All pavement shall be cut by a mechanical saw.
- C. The Contractor shall also protect the street surfaces outside of the trench limits and shall repair all damage done thereto as a result of his operations.

3.2 REMOVAL AND STORAGE OF MATERIAL:

- A. In the business districts or in streets that are important thoroughfares, or in narrow streets or at any other locations where the working space is limited, the material excavated from the first 100 feet of any opening, or from such additional length as may be necessary, when required by the Borough, shall be removed from the area as soon as excavated. The material subsequently excavated shall be used to refill the trench, except within Borough streets or State highways where the material used to refill the trench shall consist of 2A coarse aggregate free of slag backfill material. In no case will the Contractor be allowed to cast excavated material beyond the curb or right-of-way lines, or on sidewalks or lawns.

- B. In case more material is excavated from the trench than can be backfilled over the completed pipe or can be stored on the street or within the limits of the right-of-way, leaving space for the traffic and drainage as herein provided, the excess material shall be removed to some convenient place provided by the Contractor. The Contractor shall bring back as much of the material so removed, as may be required to properly backfill the trench, or if the proper kind; or, if so required by the Borough, the Contractor shall furnish such other suitable material as may be necessary.
- C. When it is necessary to haul soft or wet material over the streets, the Contractor shall provide suitable tight vehicles to prevent spillage.
- D. All topsoil shall be removed from the limits of trenches before the commencement of trench excavation. After the trenches are backfilled, the topsoil shall be replaced. A minimum of 6 inches of topsoil shall be provided.

3.3 ORDER OF WORK:

- A. The Contractor shall submit a progress schedule and shall carry on his work in strict accordance therewith. Deviations from the progress schedule may be made only with the approval of the Borough.
- B. Service connections shall be constructed either at the same time as the main or immediately after its completion.
- C. All street paving shall be replaced by the Contractor, after which the street surfaces shall be cleaned as specified herein. The Borough shall use their discretion if the conditions are suitable for placement of paving or if the contractor shall wait until conditions are favorable.
- D. The failure of the Contractor to comply with these requirements concerning installation of service connections and manholes, repaving and cleaning of streets shall be sufficient cause for the Borough to stop all other work on the project until these requirements have been met.

3.4 SEWER LINES AND GRADES:

- A. Sewer lines and grades shall be laid out and maintained during construction in the following manner.
- B. Before beginning the excavation for any run of main sewer, the Contractor's forces shall set control points for line and grade. In unpaved or unsurfaced areas, these points shall be placed on the top of stakes securely driven into the ground. In paved areas, they may be spikes driven into the paving or crosses cut into the paving, and, in either case, enclosed in a painted circle. Stakes or points shall be sufficiently offset from the centerline so as to be undisturbed during the excavation and pipe laying operations. The offset shall be on the side of the centerline opposite to that on which excavation will be thrown. The first stake or point shall be set 25 feet distant from the manhole having the lower invert;

succeeding stakes shall be set 25 feet apart. Elevations of the top of stakes, or if points are used, on the surface of the paving on the centerline of the sewer opposite the points, shall be taken by the Contractor, using a surveyor's level. The Contractor shall record these elevations and compute the depths of cut to the invert of the sewer and mark both the stationing and the computed depths of cut on each stake with keep or on the road surface with paint. The Contractor shall use these depths of cut as guides for the rough excavation, making due allowance for excavating to the lower depth to accommodate the required pipe bedding, and for concrete cradles or concrete encasements. Excavation shall begin at the manhole having the lower invert and proceed upgrade.

3.5 WIDTH AND DEPTH OF TRENCHES:

- A. From the subgrade elevation to an elevation at least 12 inches above the top of the outside barrel of the pipe, the banks of trenches in all cases shall be excavated to vertical lines and the trenches shall be not less than 12 inches nor more than 16 inches wider than the outside diameter, at the barrel of the pipe to be laid therein. The trenches shall be excavated true to line so that a clear space not less than 6 inches or more than 8 inches in width is provided on each side of the barrel of the pipe. If sheeting is required, the foregoing dimensions shall be applicable to the inside faces of the sheeting.
- B. From a point 12 inches above the top of the outside barrel of the pipe to the surface, the banks of trenches in all streets, roads or highways, paved or unpaved, shall be kept as nearly vertical as possible, and in no case shall the width of the trench at the top exceed the outside diameter of the pipe plus 40 inches. If the specified maximum width of the trench cannot otherwise be maintained, the Contractor shall install temporary sheeting. Where mains are to be constructed in rights-of-way or easements in open country, the specified maximum width of the trench at the top may be exceeded only if construction is kept entirely within the limits of the easements or rights-of-way and can be carried on without damage to adjoining property. The angle of slope shall be the angle at which the trench bank will stand without sliding and in no case shall the angle of slope be steeper than one-half horizontal to one vertical.
- C. In locations other than on easements or rights-of-way, the Borough may, as warranted by working conditions and, where permitted by the Pennsylvania Department of Labor and Industry requirements, waive the requirements that the maximum width at the top of the trench shall not exceed the outside diameter of the pipe plus 40 inches. Proper shoring methods are the responsibility of the contractor.
- D. Except at locations where excavation of unsuitable material is required, care shall be taken not to excavate below the depths specified. When the material encountered at subgrade is unstable, or where, in the opinion of the Engineer, the ground does not afford a sufficiently firm foundation, the Contractor shall excavate

the trench to such increased depth as may be required by the Borough and then shall refill the trench to subgrade with crushed stone conforming to PennDOT's grading and quality requirements for No. 1B coarse aggregate, thoroughly compacted to the satisfaction of the Borough, or if required by the Borough, the Contractor shall construct a timber foundation. If earth trenches are excavated beyond the specified depths without written requirements of the Borough, they shall be backfilled to the proper grade with thoroughly tamped No. 1B crushed stone.

3.6 LENGTH OF TRENCH:

- A. No trench shall be opened more than 100 feet in advance of the pipe lines laid. The Contractor shall limit all trench openings to a distance commensurate with all rules of safety.
- B. If the work is stopped either totally or partially, the Contractor shall provide adequate plates, flashers, etc. to protect the motorist and pedestrian during non-working hours. All open trenches shall be covered during non-working hours.

3.7 PUMPING AND DRAINING:

- A. The Contractor shall remove, by pumping or draining, any water which may accumulate in the trenches and other excavations and shall build all dams and do all other work necessary to keep the trenches or other excavation as free from water as possible. Where it is impractical to completely drain the trench, special pipe or jointing materials may be authorized at no additional expense to the Owner. While the pipelines are being laid, the Contractor shall have sufficient pumping machinery ready for immediate use. All surface waters shall be prevented from entering the open ditches or excavations by proper grading of the surface in the vicinity of the excavation. Erosion and sediment control shall be exercised in accordance with the approved plan. Under no circumstances shall any pumped water be discharged to any sanitary sewer.

3.8 MAINTENANCE OF GUTTERS:

- A. The Contractor shall keep the gutters open at all times so the flow, storm or other waters shall not be obstructed. If the material excavated from the trenches must temporarily extend over the gutters, it shall be the duty of the Contractor to plank or bridge over the gutters, without extra compensation, so the flow of water is not impeded. Erosion and sedimentation control shall be exercised in accordance with the approved plan.

3.9 MAINTENANCE OF TRAFFIC:

- A. Work shall be conducted so as to cause minimum inconvenience to pedestrian and vehicular traffic and to private and public properties along the line of work. It shall be the duty of the Contractor, at all times, to maintain crossing, walks,

sidewalks, and other roadways open to the traffic and in a satisfactory condition, and to keep all fire hydrants, water valves, fire alarm boxes, manholes, and letter boxes accessible for use. Whenever it is necessary to maintain pedestrian traffic over open trenches, a timber bridge at least three feet in width and equipped with side railings shall be provided. When the excavated material will encroach upon sidewalks or private property, planking shall be placed in order to keep the sidewalk or private property clear of excavated material.

- B. In important thoroughfares, highways or narrow streets, the material excavated from the trench shall be removed from the site of the work at the Contractor's expense and to bring back as much of the accepted material as necessary to properly refill the trench; or they shall, at their own cost and expense, furnish such other suitable materials as may be necessary to properly refill the trench.
- C. When it is necessary to haul soft or wet materials over public streets, the Contractor shall provide suitable vehicles and shall conform to all laws and ordinances relevant to such hauling.
- D. Maintenance and protection of traffic on Borough streets and State highways shall be in strict accordance with PennDOT Publication 213. The Contractor shall adjust the sign locations daily in order to protect that section of highway to be disturbed during that same day.

3.10 ROCK EXCAVATION:

- A. Unless otherwise accepted by the Borough, rock shall be fully taken out at least 25 feet in advance of pipe laying to subgrade as defined herein, and to a width not to exceed the specified width of the trench, for the size of pipe to be laid therein.
- B. If rock below the specified grade is shattered due to excessive drilling or blasting, and if, in the opinion of the Borough, it is unfit for foundation, such shattered rock shall be removed and the area backfilled to the proper grade with concrete or other material acceptable to the Borough.
- C. Where manholes are excavated in rock, they shall be excavated one foot outside the exterior lines of the walls of the manholes and to a depth of six inches below the bottom.
- D. All excavated material which is unfit for refilling must be immediately removed from the site of the work.
- E. Wherever rock is encountered in the excavations for manholes in which blank connections are to be left for future extensions of the sewers, the rock shall be excavated for a distance of not less than 10 feet from the center of the manhole, in the direction of the proposed extension of the sewer, and the excavation shall conform to the lines of the prism required by the dimensions of such extension.

3.11 BLASTING:

- A. All blasts shall be properly matted and securely covered. The Contractor shall be solely responsible for injury to persons or property located within or beyond the area or scope of the project that may result from this use of explosives.
- B. All blasting shall be done under the supervision of a Licensed Blaster and subject to State, Federal, including the Department of Labor and Industry, county or local regulations for blasting. Whenever any pipe main or conduit is encountered in the trench, all material within five feet of the same shall be removed by some method other than blasting or as otherwise governed by the owner of the utility.
- C. The Contractor will be responsible for the depths to which all blasting is performed.
- D. Should any street paving adjoining any trench be damaged in consequence of the Contractor's blasting operations, they shall immediately cease their blasting operations and repair the damaged street paving; also, they shall not again proceed with any blasting until he has submitted to and obtained approval from the Borough.

3.12 BRACED AND SHEETED TRENCHES:

- A. Open cut trenches shall be sheeted and braced as required by any governing Federal and State laws, and municipal ordinances, and as may be necessary to protect life, property or the work. The cost of furnishing, placing and removing the sheeting and bracing necessary to protect life, property or the work shall be included in the bid price for the pipe.

3.13 CAUTION IN EXCAVATION:

- A. The Contractor shall proceed with caution in the excavation and preparation of the trench so that the exact location of underground structures, both known and unknown, may be determined, and he shall be held responsible for the repair of such structures when broken or otherwise damaged because of carelessness on their part.

3.14 SUBSURFACE EXPLORATIONS:

- A. Whenever, in opinion of the Borough, it is necessary to explore and excavate to determine the location of existing underground structures, the Contractor shall make explorations and excavations for such purposes. If the Contractor is required to perform additional work in making the explorations and excavations, the cost of said work shall be borne by the Contractor.

3.15 PIPE BEDDING AND INITIAL BACKFILL:

- A. The trench shall be excavated to a depth of six inches below the outside diameter of the pipe barrel, or deeper if so specified. The resultant subgrade shall be

undisturbed. The bedding shall then be prepared by placing #8 or #57 stone in 6-inch uncompacted layers to 12-inches above top of pipe. Bedding shall provide uniform and continuous bearing and support for the pipe at every point between bell holes.

3.16 CONCRETE CRADLE AND CONCRETE ENCASEMENT:

- A. The trench shall be excavated to a depth of 6 inches below the outside of the barrel of pipes 24 inches or less and 9 inches below the outside of the barrel of pipes larger than 24 inches in diameter. All of this excavation may be done by machine. Quality of concrete and method of placement is specified elsewhere.

3.17 UNSTABLE SUBGRADE:

- A. Where the bottom of the trench at subgrade is found to be unstable or to include ashes, cinders, any type of refuse, vegetable or other organic material, or large pieces of fragments of inorganic material which, in the opinion of the Borough, should be removed, the Contractor shall excavate and remove such unsuitable material to the width and depth recommended by the Borough. Before pipe is laid, the subgrade shall be made by backfilling with No. 8 or No. 57 stone (or larger if deemed necessary by the Borough) in 6-inch uncompacted layers, thoroughly tamped and the bedding prepared as hereinbefore specified.

3.18 SPECIAL FOUNDATIONS:

- A. Where the bottom of the trench at the subgrade is found to consist of material which is unstable to such a degree that, in the opinion of the Borough, it cannot be removed and replaced with an accepted material thoroughly compacted in place to support the pipe properly, the Contractor shall construct a foundation for the pipe, consisting of piling, timber or other materials, in accordance with Borough Specifications.

3.19 EXCAVATION IN FILL:

- A. When the pipe is laid in fill, the compacted embankment shall be brought to a height of at least 12 inches above the proposed top of the pipe before the trench is excavated. Compaction testing shall be conducted by a third-party testing agency. Compaction test results shall be provided to the Borough Engineer for review. Backfill material shall be compacted to a minimum density of 95 percent proctor (ASTM D 1577).

3.20 EXCAVATION METHODS:

General: Backfilling shall not be done in freezing weather except by permission of the Borough, and it shall not be made with frozen material. No fill shall be made where the material already in the trench is frozen. Any consolidation method utilizing water, such as jetting or puddling shall not be permitted.

3.21 BACKFILL TO RESTORATION DEPTH:

- A. State, Borough, and Township Roads Including Driveways: From one foot above the top of the pipe to restoration depth, the trench shall be backfilled by hand or by accepted mechanical methods. Backfill in this section of the trench shall be 2A Aggregate material. Contractor shall submit, prior to beginning construction, a list of the compaction equipment to be utilized on the project, the recommendations of the equipment manufacturer as to the maximum lift thickness that can be placed, and the method of compaction. In no case shall lift thickness placed exceed the limits specified by the manufacturer's recommendations or a maximum of two feet, whichever is the smaller. However, if the equipment manufacturer's specified compaction is followed and the specified compaction is not obtained, the Contractor shall, at their own expense, remove, replace and retest as many times as is required to obtain the specified compaction. Consolidation shall proceed from the center of the trench to the sides to prevent arching. Backfill material shall be compacted to a minimum density of 95% proctor (ASTM D1557) or as required by PennDOT or Municipality having jurisdiction. Compaction testing shall be performed by a geo-technical engineer hired by the contractor to confirm proper compaction is being achieved. Compaction test reports shall be provided to the Authority Engineer no later than one (1) week of the compaction testing.
- B. Lawn, Meadows and Cultivated Fields: From one foot above the top of the pipe to restoration depth, the trench shall be backfilled by hand or by accepted mechanical methods. Backfill in this section of the trench shall be suitable backfill material. Contractor shall submit, prior to beginning construction, a list of the compaction equipment to be utilized on the project, the recommendations of the equipment manufacturer as to the maximum lift thickness which can be placed, and the method of compaction to be used with this equipment to achieve the required compaction. In no case shall lift thickness place exceed the limits specified by the manufacturer's recommendations or a maximum of two feet, whichever is the smaller. However, if the equipment manufacturer's specified compaction is followed and the specified compaction is not obtained, the Contractor shall, at their own expense, remove, replace and retest as many times as is required to obtain the specified compaction. Consolidation shall proceed from the center of the trench to the sides to prevent arching. Backfill material shall be compacted to a minimum density of 95% proctor (ASTM D 1557).

3.22 CLEAN-UP:

- A. During construction, the surfaces of all areas including, but not limited to, roads, streets and driveways shall be maintained on a daily basis to produce a safe, desirable and convenient condition. Streets shall be swept and flushed after backfilling and re-cleaned as dust, mud, stones and debris caused by the work, or related to the work again accumulates. At no time should mud, stones, water or debris be allowed to enter the sanitary sewer or storm sewer facilities. Failure of

the Contractor to perform this work shall be cause for the Borough to order the work by others, and back charge all costs to the Contractor. The Contractor is not permitted to wash, sweep or place any construction clean-up activities into the sanitary sewer system.

- B. All surplus materials furnished by the Contractor and temporary structures shall be removed from the site by the Contractor. All dirt, rubbish and excess earth from the excavation shall be disposed of by the Contractor in a manner and place acceptable to all governing agencies. The construction site shall be left clean at the end of each working day to the satisfaction of the Borough. All surplus materials furnished by the Borough and delivered to the site by the Contractor shall be removed and delivered by the Contractor to a location designated by the Borough. All surplus materials furnished and delivered by the Borough will be removed by the Borough.
- C. In the execution of this work, the Contractor shall conform to the approved erosion and sedimentation control plan.

3.23 RESTORATION OF UNPAVED AREAS:

- A. The Contractor shall crown to such height as required by the Borough the top of all backfilled excavation in all unpaved areas, where such areas are not used as a way for vehicles.

3.24 RESPONSIBILITY FOR CONDITION OF EXCAVATION:

- A. The Contractor shall be solely responsible for the condition and results of all excavations made by them. All slides and cave-ins shall be removed by the Contractor at whatever time and under whatever circumstances they may occur.
- B. The failure or refusal of the Borough to suggest the use of bracing or sheeting; or a better quality, grade or section, or larger sizes of steel or timber; or to suggest sheeting, bracing, struts or shoring to be left in place, shall not in any way or to any extent relieve the Contractor of any responsibility concerning the condition of excavation or any of their obligations, nor impose any liability on the Borough Engineer or the Borough; nor shall any delay, whether caused by any action or want of action on the part of the Contractor, or by any act of the Borough Engineer, Borough or their agents or employees resulting in the keeping of an excavation open longer than would otherwise been necessary, relieve the Contractor from the necessity of properly and adequately protecting the excavation from caving or slipping, nor from any of their obligations relating to injury of persons or property.

3.25 PROTECTION OF UTILITIES, PROPERTY AND STRUCTURES:

- A. The Contractor shall notify all utility companies in advance of construction to include requesting the utilities to be located in accordance with Pennsylvania Act 187, and cooperate with agents of these companies during the progress of the

work. Procedures for emergency action and repairs to utilities shall be established with the utility company prior to commencement of the work. During the course of their work, if the Contractor damages any of the aforementioned utilities, they shall immediately follow the procedure of emergency action and repair as established at their own expense.

- B. Whenever the Contractor, during the progress of the excavation, shall uncover service pipes or lines, which because of injury or age are in poor condition, they shall immediately notify the proper Borough in order that steps may be taken for replacement or repair. Locations of repairs, and the procedures of repairs that have been made shall be recorded by the Contractor.
- C. The Contractor shall, at their expense, sustain in their places and protect from direct or indirect injury all pipes, conduits, tracks, walls, buildings and other structures or property in the vicinity of their work, whether above or below the ground, or that may appear in the trench. They shall at all times have a sufficient quantity of timber and plank, chains, ropes, etc. on the ground and shall use them as necessary for sheeting their excavations and for sustaining or supporting any structures that are uncovered, undermined, endangered, threatened or weakened, whether such structures are or are not shown on the drawings.
- D. Pipes and underground conduits exposed as a result of the Contractor's operations shall be adequately supported along their entire exposed length by timber or planking, installed in such a manner that the anchorage of the supporting members will not be disturbed or weakened during the backfilling operation. Backfill of selected material shall be carefully rammed and tamped under and around the supports and all supports shall be left in place as a guard against breakage of the supported structure due to trench settlement.
- E. Where necessary, in order to keep one side of the street or roadway free from any obstruction or to keep the material piled alongside of the trench from falling on private property outside the right-of-way, a safe and suitable fence shall be placed alongside the trench.

3.26 REMOVAL OF OBSTRUCTIONS:

- A. Should the position of any pipe, conduit, pole or other structures above or below the ground be such as, in the opinion of the Borough, to require its removal, realignment or change will be done by the Contractor or will be done by the Owner of the obstructions, however, should this work be done by the Owner of the obstructions, the Contractor shall uncover and sustain the structures before such removal and before and after such realignment or change as constituting part of the work of the project.
- B. The Contractor shall break through and reconstruct, if necessary, the invert or arch of any storm sewer, culvert or conduit that may be encountered, if the said structure is in such a position that in the judgment of the Borough and Borough

Engineer, as not to require its removal, alignment or complete reconstruction. Said work shall be discussed with the Borough and Borough Engineer prior to being performed.

- C. The Contractor shall not interfere with any persons, firms or corporations, or with the Borough in protecting, removing, changing or replacing their pipes, conduits, poles or other structures; but they shall suffer said persons, firms or corporations, or the Borough to take all such measures as they may deem necessary or advisable for the purpose aforesaid. At railway or railroad track crossings, any expense to which the owner of the trackage is put, in shoring up tracks, or in maintaining traffic shall be borne by the Developer and/or Contractor whether the same is billed directly to them or to the Borough.
- D. Trees in rights-of-way shall not be cut down except by authorization of the Borough.
- E. Shrubbery which would interfere with the construction shall be carefully removed, protected and replanted or replaced by the Contractor.

3.27 REPLACEMENT OF STRUCTURES BY CONTRACTOR:

- A. The Contractor shall restore (unless otherwise stipulated) all sidewalks, curbing, gutters, shrubbery, fences, poles, sod or other property and surface structures removed or disturbed as part of the work to a condition equivalent to that before the work began, furnishing all labor and materials incidental thereof.
- B. Replacement of curbs, sidewalks, gutters and drainage structure shall be in full accordance with the materials and methods in these Borough Specifications, unless otherwise specified.

END OF SECTION

G:\BEng-Data\Projects\17-188-01\Specifications\Water\07-2201.doc

SECTION 02665

WATERMAINS AND APPURTENANCES

SECTION 02665 - WATERMAINS AND APPURTENANCES

PART 1 - GENERAL

1.1 RELATED SECTIONS:

Section 02201 - Trench Excavation and Backfill

1.2 DESCRIPTION OF WORK:

- A. The work within this section includes, but is not limited to, the furnishing of all equipment, labor and material, and in performing all operations in connection with the installation of water mains, valves, fire hydrants, manholes, joint materials, water services and appurtenances and in performing all tests required. All work shall be in accordance with the specifications, applicable drawings and contract documents.

1.3 QUALITY ASSURANCE:

- A. Referenced standards shall be the following:
1. American National Standard Institute (ANSI)
 2. American Society for Testing and Materials (ASTM)
 3. National Sanitation Foundation (NSF 61)
 4. American Water Works Association (AWWA)

1.4 SUBMITTALS:

- A. Certificates: Contractor shall submit three (3) copies of each manufacturer's certification attesting that the materials meet or exceed specification requirements.
- B. Shop Drawings: Submit manufacturer's descriptive and technical product data for pressure pipe, fittings, etc. prior to the start of work for approval in accordance with Section 01300.

PART 2 - PRODUCTS

2.1 DUCTILE IRON PIPE AND FITTINGS:

- A. Pipe: All pipe shall be ductile iron in full accordance with the Standard Specifications as set forth in the ANSI Specification A21.51 or AWWA Specifications C151, latest edition, with wall thickness in full accordance with the Standard Specifications as set forth in the ANSI Specification A21.50 or AWWA Specification C150, latest edition.
- B. Thickness: Minimum pipe thickness shall be Class 52 for all pipe and fittings.
- C. Joints: Joints shall be of the push-on type or mechanical joint type in full accordance with ANSI A21.11 or AWWA C111 Specifications, latest edition.

D. Linings: Cement mortar linings shall be in full accordance with ANSI Specification A21.4 and AWWA C104, latest edition, except the thickness of linings should not be less than the following:

3" through 12"	1/8"
14" through 24"	3/16"

E. Encasement: Polyethylene encasement shall be in accordance with ANSI/AWWA C105-77 Specifications, latest edition.

F. Fittings: All fittings shall be ductile iron in full accordance with the Standard Specification set forth in the ANSI A21.10 or AWWA C110 Specifications, Latest Edition.

An alternative to ductile iron fittings may be Harco Ductile Iron Mechanical Joint Fittings. The fittings shall be designed to 350 psi working pressure, Class 53 ductile iron, ASTM A536-72, Grade 80-55-06 Ductile Iron.

G. Restrained Joints: Restrained joint pipe and fitting shall meet the specifications contained herein. Restrained joints shall be capable of being deflected after assembly. The joints shall be designed for a water working pressure of 350 psi.

H. Mechanical Joint Retainer Glands: Retainer glands shall be U.L. listed ductile iron meeting AWWA C11-64 (ASAA21.11) and of adequate construction to withstand twice the rated working pressure of the adjoining pipe or fitting, whichever is greater. Set screws shall be heat treated A151 4140 steel. All components of dissimilar metal shall be protected from corrosion by hand application of a bituminous coating.

I. Tie-Rods: The rods shall be constructed of suitable material and adequate dimensions to withstand at least twice the rated working pressure of the adjoining pipe or fitting, whichever is greater. All components of dissimilar metal shall be protected from corrosion by hand application of a bituminous coating.

2.2 VALVES:

A. Gate Valves: Valves shall be iron body compression resilient seated disc type with restrained joint ends as called for on the plans. All buried valves shall be non-rising stem type with "O" rings. The design of the valve and seal plate shall be such that the seal plate can be fitted with new "O" rings while the valve is under pressure in the fully open position. Valves shall be equipped with a 2-inch square operating nut and adjustable cast iron valve boxes and covers as herein specified. Gate valves shall open counter-clockwise. Gate valves shall be manufactured in accordance with the latest revision of AWWA Specification C-500 as minimum requirement, and shall be as manufactured by American Flow Control, or equivalent equal.

B. Check Valves: Valves shall be standard iron body swing type with straightaway passages for full pipe area. Valves shall be bronze mounted with self-adjusting rubber or leather-faced discs. Valves shall be either plain type or equipped with outside lever

and shall have joint ends as shown on the plans. Check valves shall be manufactured in accordance with AWWA C508.

- C. Air Release Valve: The work shall include the complete assembly with tap, shutoff valve, blowoff, air valve, piping with fittings and union, all complete and ready for operation. Air valves shall be a special stainless-steel float enclosed in the valve body with an attached lever for opening and closing the air discharge port. The design of the float and lever shall be such as to ensure opening of the valve port under maximum internal pressure. The assembly shall neither leak nor the valve stick under service conditions. All components of the valve assembly shall be stainless steel material. Valves shall be A.R.I. Valves, Inc., or approved substitution.
- D. Valve Boxes: Valve boxes shall be adjustable roadway type constructed of cast iron with a 5 ¼ inch shaft provided with screw type extension pieces and either round or oval detachable base. Box shall have a plug lid fitting into a recessed seat. The lid shall have the word "WATER" cast on the top surface. All parts of the box shall be of tough gray iron, free from cold shuts and blow holes and shall be painted with black bituminous paint. Valve boxes shall be set at or above the surface of the adjoining ground or roadway.

2.3 HYDRANTS:

- A. Hydrants shall be Kennedy Model K81-D. Refer to Authority Detail 59.

2.4 WATER SERVICE LINES:

- A. Multiple service to more than one property for a water service line is not permitted. A single water connection to the Borough's system for each property is required.
- B. All ¾ inch to 2-inch water service lines shall be on continuous piece of copper tubing from the corporation stop to the curb stop or water meter pit. Copper tubing shall be in conformance with ASTM B88, Type K, for ¾ inch to 2-inch lines.
- C. At the discretion of the Authority, water service lines from the curb stop or water meter pit may be constructed of High-Density Polyethylene (HDPE) Tubing: Meeting the requirements of ASTM D2737, AWWA C901, and NSF/ANSI Standards 14 and 61. Pipe dimensions shall meet SDR-9 Copper Tubing Size (CTS) standards.
- D. Fire service lines shall be ductile iron pipe meeting the requirements listed in Paragraph 2.1 of this specification section.
- E. Service Line Fittings: Threads for underground service line fittings shall be in full accordance with AWWA C800.
- F. Corporation Cocks: Inlet thread shall be Mueller or iron pipe type as directed, with flange union couplings or wiped joints. Type shall be Mueller or approved substitution.
- G. Curb Stops: Ground key for use with copper water service. Make shall be Mueller or approved substitution.

- H. Curb Boxes: Extension type with the stationary rod. Pattern shall be approved by Borough. The boxes and lids shall be coated with bituminous enamel. Extension range shall be 42 inches to 60 inches.

2.5 MISCELLANEOUS:

- A. Concrete Thrust Blocks: Thrust blocks shall be in accordance with the latest revision of ANSI/AWWA C600 and shall be constructed to the dimensions shown on the plans. Care shall be taken during the concrete placement so that no joint nuts and bolts come in contact with the concrete.
- B. Tapping Sleeves and Valves: Tapping sleeves and valves shall be of the sizes shown on the drawings and shall be designed to operate at a working pressure of ~~200~~ 250 psi unless otherwise specified. Tapping sleeves shall be Muller H615 or approved equal. The valves shall be inside screw, iron body, compression resilient seated disc with either mechanical joint or hub ends and 2-inch square operating nuts. Valves shall open to the left.
- C. Mortar: Mortar for jointing and plastering the outside of brick manholes shall consist of one part Portland cement and two parts fine sand. For brickwork, lime may be added to the mortar in an amount of not more than 25 percent of the volume of the cement. Sand shall be clean and sharp and conform to the ASTM Specification C-144. Hydrated lime shall conform to ASTM Specification C-6. Retempered mortar or mortar which has been mixed for more than 45 minutes shall not be used.
- D. Concrete: Concrete shall have a compressive strength of not less than 3,000 psi after 28 days (tests to be in accordance with Standard Method of Compression Tests of ASTM).
- E. Cast Iron: Gray iron castings shall be manufactured from iron conforming to ASTM A48, Class 35B, as noted in Section 3.1 of AASHTO M306. The iron material used in products provided shall have a minimum recycled material content of 75 percent. The recycled materials shall consist of post-consumer material.
- F. Frames/Covers: Manhole frame and cover shall be of cast gray iron with self-sealing cover as manufactured by Neenah Foundry Company frame model R-1642, cover model R-1642 (Type B) or approved equivalent, machined and having the words "WATER" cast approximately in the center of the cover. Frames shall be securely attached to the top of the manhole section by four stainless steel anchor bolts at 180 degrees C to C. Gray iron castings shall be manufactured from iron conforming to ASTM A48, Class 35B, as noted in Section 3.1 of AASHTO M306. The iron material used in products provided shall have a minimum recycled material content of 75 percent. The recycled materials shall consist of post-consumer material. Joint material between the frame and manhole or grade ring shall be as specified in Manhole Joint Sealing Material. The top of the manhole lid shall not extend above the frame.

2.6 INSPECTION:

- A. Field Inspection: All pipe and appurtenances shall be furnished, installed and tested for defects in material and/or workmanship in the manner specified and in the presence of and as accepted by the Borough.
- B. Disposition of Defective Material: All material found during the progress of the work to have cracks, flaws or other defects will be rejected by the Borough. All defective materials furnished by the Contractor shall be promptly removed by him from the site at his own expense.

2.7 HANDLING OF MATERIAL:

- A. Replacement of Damaged Material: The Contractor shall replace, at their own expense, all material furnished by them and found defective in manufacture or damaged in handling after delivery by the manufacturer. This shall include the furnishing of all materials and labor required for replacement of installed material. Any material furnished by the Borough that becomes damaged after acceptance by the Contractor shall be replaced by the Contractor at his own expense.
- B. Responsibility for Safe Storage: The Contractor shall be responsible for the safe storage of material furnished by or to them, and accepted by them, and intended for the work, until it has been incorporated in the completed project. The interior of all pipe, fittings and other accessories shall be kept free from dirt and foreign matter at all times. All equipment and materials subject to damage from freezing shall be drained and stored in a manner which will protect them.
- C. Hauling: All materials furnished by the Contractor shall be delivered and distributed at the site by the Contractor. Materials furnished by the Borough shall be picked up by the Contractor at points designated and hauled to and distributed at the site.
- D. Care of Pipe Coating and Lining: Pipe shall be handled so the lining will not be damaged. If, however, any part of the lining is damaged, the repair shall be made by the Contractor at his expense in a manner satisfactory to the Borough.

PART 3 - CONSTRUCTION

3.1 MAINTENANCE OF FLOW:

- A. The Contractor shall be responsible for coordinating and maintaining construction of all existing watermains, water services and fire hydrants. The Contractor shall submit their plans for maintenance of flow prior to the start of construction for approval by the Borough.

3.2 PIPE INSTALLATION:

- A. General: All pipe shall be laid and maintained to the required lines and grades with fittings and valves at the required locations; spigots centered in bells; and all valves

plumb. The pipe shall be laid in the backfill materials as specified. Pipe laying shall commence at the lowest point and proceed upgrade.

- B. Caution in Excavation: The Contractor shall proceed with caution in the excavation and preparation of the trench so that the exact location of underground structures, both known and unknown, may be determined, and he shall be held responsible for the repair of such structures when broken or otherwise damaged because of carelessness on their part.
- C. Depth of Pipe: All pipe shall be laid to the depth shown on the contract drawings or a minimum of 4.0 feet from finished grade to the crown of pipe.
- D. Handling of Water Main Material into Trench: Proper implements, tools and facilities satisfactory to the Borough shall be provided and used by the Contractor for the safe and convenient prosecution of the work. All pipe, fittings, valves, etc., shall be carefully lowered into the trench piece by piece by means of a derrick, ropes or other suitable tools or equipment, in such a manner as to prevent damage to sewer line materials, protective coatings and linings. Under no circumstances shall such materials be dropped or dumped into the trench.
- E. Hammer Test: The pipe and fittings shall be inspected for defects and while suspended above grade, be rung with a light hammer to detect cracks.
- F. Cleaning Pipe and Fittings: All lumps, blisters and excess coal tar coating shall be removed from the bell and spigot end of each pipe, and the outside of the spigot and the inside of the bell shall be wire-brushed and wiped clean and dry and free from oil and grease before the pipe is laid.
- G. Laying Pipe: Every precaution shall be taken to prevent foreign material from entering the pipe while the pipe is being placed in the line. If the pipe-laying crew cannot put the pipe into the trench and in place without getting into it, the Borough may require that before lowering the pipe into the trench, a heavy, tightly woven canvas bag of suitable size shall be placed over each end and left there until the connection is to be made into the adjacent pipe. During laying operations, no debris, tools, clothing or other materials shall be placed in the pipe.
- H. Cutting Pipe: The cutting of pipe for inserting valves, fittings or closure pieces shall be done in a neat and workmanlike manner, without damage to the pipe, so as to leave a smooth end at right angles to the axis of the pipe.
- I. Permissible Deflection of Joints: If deflection is required, make after joint is assembled. The amount of deflection shall not exceed 50 percent of the maximum limits as specified in the AWWA Standard C600, latest revision.
- J. Unsuitable Conditions for Laying Pipe: No pipe shall be laid in water or when, in the opinion of the Borough, trench conditions are unsuitable.
- K. Variations: The Borough reserves the right to vary the line and/or grade from that shown on the drawings for the pipe lines and manholes and to vary the location of fittings, valves and hydrants when such changes may be necessary or advantageous.

- L. Mechanical Joints: The spigot end of the pipe shall be centrally located in the bell so that the rubber gasket is evenly seated.
- M. All loose rust or foreign matter shall be removed from the inside surfaces of the bell and outside surface of the spigot prior to assembly. Bolts shall be tightened uniformly with a ratchet wrench so as to affect the joint seal. The normal range of bolt torques to be applied are:

<u>Bolt Size-Inches</u>	<u>Torque-Ft. Lbs.</u>
5/8	45 - 60
3/4	75 -90
1	100 - 120
1-1/4	120 - 150

- N. If effective sealing is not attained at the maximum torque indicated above, the joint shall be disassembled and reassembled after thorough cleaning.
- O. Push-On Type Joints: The joint shall be assembled as recommended by the manufacturer so as to affect the joint seal.
- P. A minimum of 18 inches vertical separation shall be provided between the water main and any pipe crossing. If 18 inches of clearance cannot be achieved, the other utility shall be encased in concrete. The concrete encasement shall extend 10 feet on each side of the pipe crossing.
- Q. A minimum of 10 feet horizontal separation shall be provided between the sanitary sewer pipe and any water main.
- R. A minimum of 5 feet horizontal separation shall be provided between the water main and all other utilities (i.e. gas, electric, telecommunications, storm water, etc.).

3.3 FITTINGS AND VALVES:

- A. General: Valves and fittings shall be set and jointed to pipe in the manner heretofore specified for cleaning, laying and jointing pipe.
- B. Valve Boxes and Valve Pits: A cast iron valve box or a masonry pit shall be provided for every valve as shown on the plans. A valve box shall be provided for every valve which has no gearing or mechanism or in which the gearing or operating mechanism is fully protected with a cast iron grease case. The valve box shall not transmit shock or stress to the valve and shall be centered and plumb over the wrench nut of the valve, with the box cover flush with the surface of the finished pavement or such other level as may be directed.
- C. Drainage of Mains: Mains shall be drained through drainage branches or blow-offs to dry wells from which the water can be pumped. Drainage branches, blowoffs, air vents and appurtenances shall be provided with gate valves and shall be located and installed as shown on the plans.

3.4 HYDRANTS:

- A. Location: Hydrants shall be located as shown on the plans or as directed by the Borough in a manner to provide complete accessibility and so that the possibility of damage from vehicles or injury to pedestrians will be minimized.
- B. When placed behind the curb, the hydrant barrel shall be set so that no portion of the pumper or hose nozzle cap will be less than 6 inches or more than 12 inches from the gutter face of the curb.
- C. When set in the lawn space between the curb and sidewalk, or between the sidewalk and the property line, no portion of the hydrant or nozzle cap shall be within 12 inches of the sidewalk.
- D. Position: All hydrants shall stand plumb and shall have their nozzles parallel with or at right angles to the curb, with the pumper nozzle facing the curb, except that hydrants having two hose nozzles 90 degrees apart shall be set with each nozzle facing the curb at an angle of 45 degrees. Hydrants shall be set to the established grade, with the nozzles at least 12 inches above the ground, as shown or as directed by the Borough.
- E. Connection to Main: Each hydrant shall be connected to the main with a 6-inch branch controlled by an independent 6-inch gate valve except as otherwise directed.
- F. Hydrant Drainage in Pervious Soil: Wherever a hydrant is set in soil that is pervious, drainage shall be provided at the base of the hydrant by placing coarse gravel or crushed stone mixed with coarse sand, from the bottom of the trench to at least 6 inches above the waste opening in the hydrant and to a distance of 1 foot around the elbow.
- G. Hydrant Drainage in Impervious Soil: Wherever a hydrant is set in clay or other impervious soil, a drainage pit 2 feet in diameter and 3 feet deep shall be excavated below each hydrant and filled completely with coarse gravel or crushed stone mixed with coarse sand, under and around the elbow of the hydrant and to a level of 6 inches above the waste opening.

3.5 ANCHORAGE:

- A. Anchorage for Hydrants: The bowl of each hydrant shall be well braced against unexcavated earth at the end of the trench with stone slabs or concrete backing, or it shall be tied to rods or clamps as shown or as directed by the Borough.
- B. Anchorage for Plugs, Caps, Tees, and Bends: All plugs, caps, tees, and bends deflecting 11-1/4 degrees or more on mains 6 inches in diameter or larger shall be provided with a reaction backing, or movement shall be prevented by attaching suitable metal rods or clamps as shown on the plans or as directed by the Borough. All lateral line valves shall be rodded to the main line tee with 3/4 inch threaded tie rods if a flanged or restrained joint is not utilized.

- C. Reaction Backing: Reaction backing shall be concrete of a mix not leaner than 1 part cement, 2-1/2 sand, 5 stone, and having a compressive strength of not less than 2,000 psi, at 28 days. Backing shall be placed between solid ground and the fitting to be anchored; the area of bearing on the pipe and on the ground in each instance shall be as shown on the plans or as directed by the Borough. The backing shall, unless otherwise shown or directed, be so placed that the pipe and fitting joints will be accessible for repair.
- D. Vertical Reaction Blocking: All vertical reaction blocking shall be accepted by the Borough. Reaction blocking shall be used where any elbow or offset is used in vertical direction.
- E. Tie Rods: Metal harness of tie rods of adequate strength to prevent movement shall be used. Steel rods/clamps shall be galvanized and painted with two coats of asphalt type paint.

3.6 CONCRETE CRADLE AND ENCASEMENT:

- A. Preparation: Prior to the formation of the cradle or encasement, temporary supports consisting of solid concrete bricks or cap blocks shall have minimum dimensions and shall support the pipe at not more than two locations, one at the bottom of the barrel of the pipe adjacent to the shoulder of the socket and the other near the spigot end.
- B. Placing: After jointing of the pipe has been completed, concrete shall be uniformly poured beneath and on both sides of the pipe. Placement shall be done by the use of suitable equipment. The concrete shall be wet enough during placement to permit its flow, without excessive prodding, to all required points around the pipe surface. The width of cradle shall be such as to fill completely the trench width. In case of extremely wide trenches, concrete encasement may be confined above the top of the pipe to a narrower width, but in no case shall it be less than the width of trench required for the size of pipe being used.
- C. Before depositing concrete, the space within the limits of the pour shall have been cleared of all debris and water. Water shall not be allowed to rise adjacent to, or flow over, concrete deposited for less than 24 hours. Concrete shall be protected from the direct rays of the sun and kept moist by a method acceptable to the Borough, for a period of 7 days or until backfilling is begun. In no case shall backfill begin within 36 hours of the time of placing and the Borough shall have strict control of the rate of backfilling.

3.7 BLOWOFF CONNECTION:

- A. See Construction Detail #69.

3.8 VAULTS/PITS:

- A. General: Water system vaults/pits shall be constructed of precast concrete units with cast iron frames and covers in the locations shown on the drawings or as directed by

the Borough and in accordance with the construction details. Shop drawings shall be submitted by the Contractor for the Borough's review.

- B. Concrete or mortar shall conform to the requirements specified herein.
- C. Frames, Covers and Steps: Cast iron frames and covers and manhole steps shall conform to the drawings in all essentials of design. Standard castings differing in nonessential details and accepted by the Borough will be acceptable. Frames and covers shall be machined to produce a tight, rattleproof fit. The frames and covers shall be set that the top of the cover will be flush with or higher than the finished grade as directed by the Borough. Steps when shown on drawings or specified shall be furnished and set as manhole construction progresses.

3.9 HYDROSTATIC TESTS:

- A. Leakage Test: After the pipe has been laid and backfilled as specified, all newly laid pipe or any valve sections thereof, shall be subjected to a hydrostatic pressure of 150 pounds per square inch, or 50 percent in excess of the normal working pressure, whichever is greater.
- B. Leakage is defined as the quantity of water to be supplied into the newly laid pipe, or any valved section thereof, necessary to maintain the specified leakage test pressure after the pipe has been filled with water and the air expelled.
- C. No pipe installation will be accepted until the leakage is less than the number of gallons per hour as determined by the formula

$$L = \frac{ND(P)^{1/2}}{7400}$$

in which "L" equals the allowable leakage in gallons per hour; "N" is the number of joints in the length of pipelines tested; "D" is the nominal diameter of the pipe, in inches and "P" is the average test pressure during the leakage test, in pounds per square inch gauge. (The allowable leakage according to the formula is equivalent to 23.3 US gallons per 24 hours per mile of pipe per inch nominal diameter, for pipe in 18-foot lengths evaluated on a pressure basis of 150 psi.). The duration of the test under pressure shall be two hours.

- D. Procedure: Each valved section of pipe shall be slowly filled with water and the specified test pressure, based on the elevation of the lowest point of the line or section under test and corrected to the elevation of the test gauge, shall be applied by means of a pump connected to the pipe in a manner satisfactory to the Borough. The pump, pipe connections and all necessary apparatus including gauges, shall be furnished by the Contractor. The Contractor will make all taps into the pipe and furnish all necessary assistance for conducting the tests.
- E. Expelled Air Before Test: Before applying the specified test pressure, all air shall be expelled from the pipe. If hydrants or blow-off are not available at high places, the

Contractor shall make the necessary taps at such points before the test is made and insert the plugs after the test has been completed.

- F. Variation from Permissible Leakage: Should any test of pipe laid disclose leakage greater than that specified, the Contractor shall, at their own expense, locate, repair and replace the defective joints, pipe or fittings until the leakage is within the specified allowance.
- G. Where any section of a main is provided with concrete reaction backing, the hydrostatic pressure test shall not be made until at least five (5) days have elapsed after the concrete reaction backing was installed. If high early strength cement is used in the concrete reaction backing, the hydrostatic pressure test shall not be made until at least two (2) days have elapsed.
- H. The Borough shall be present during the operating of valves required to fill mains for pressure and leakage tests.
- I. The Contractor shall schedule the pressure and leakage test at least 48 hours in advance of the test day with the Borough. No testing will be authorized unless air temperature is greater than 35 degrees F.
- J. The pressure and leakage tests shall be monitored by the Borough.
- K. The Contractor will furnish laboratory calibrated test gauge and measuring device for the leakage test.
- L. All field joints of fittings, valves and hydrants shall be exposed and examined during pressure and leakage test.
- M. Section under test shall be brought to test pressure of 150 psi at ½ hour intervals during the testing. The Borough will record both the makeup water pressure at each ½ hour repressurization.
- N. If the test is applied against an existing valve and the Contractor has determined that said valve is passing, Contractor shall excavate valve at their expense so Borough can perform a sound test on the valve. In addition to the sound test, test section shall be valved off and post pressure applied. Borough will observe pressure for 24 hours. This section should remain at post pressure if valve is passing.

3.10 DISINFECTION OF LINES:

- A. Preliminary Flushing: Prior to disinfection, the lines shall be flushed as thoroughly as possible with the water pressure and outlets available. Flushing shall be done after the line leakage test has been made. Disinfection shall be in full accordance with the latest revision of AWWA C651 and these specifications.
- B. Chlorination of Completed Line: Before being placed in service, the entire line shall be chlorinated. Chlorine may be applied by the following methods: Liquid chlorine and calcium hypochlorite granules, sodium hypochlorite solution and calcium hypochlorite tablets.

- I. The chlorinating agent shall be applied at the beginning of the section adjacent to the feeder connection and shall be injected through a corporation cock, hydrant or other connection ensuring treatment of entire line.
 - II. Water shall be fed slowly into new line with chlorine applied in amounts to produce a dosage of 40 to 50 ppm. Mains previously filled shall be treated to a concentrated dosage at intervals along the line and retained for a period of 8 hours or more. A residual of not less than 5 ppm shall be produced in all parts of the line.
 - III. During the chlorination process, all valves and accessories shall be operated. After chlorination, the water shall be flushed from the line at its extremities until the replacement water tests are equal chemically and bacteriologically to those of the permanent source of supply.
 - IV. Contractor shall review disinfection procedures and time tables with Borough at least 3 days prior to implementing them.
- C. Liquid Chlorine: Chlorine gas-water mixture shall be applied by means of a solution feed chlorinating device. Chlorine gas shall be fed directly from a chlorine cylinder equipped with suitable device for regulating the rate of flow and the effective diffusion of gas within the pipe.
- D. Calcium Hypochlorite: Calcium hypochlorite shall be comparable to commercial products known as HTH perchloren and maxochlor, a solution consisting of 5 percent of power to 95 percent of water by weight, should be prepared. The calcium hypochlorite and water mixture, first made into a paste and then thinned to a slurry, shall be injected or pumped into the newly laid line under the conditions specified hereinbefore.
- E. Final Flushing: Following chlorination, all treated water shall be thoroughly flushed from the line, at its extremities, until the replacement water throughout its length, upon test, be proved comparable to the quality of water in the existing water system.

3.11 BACTERIOLOGICAL TESTS:

- A. Chlorination of the completed line and two bacteriological tests, for separate and discrete 24-hour intervals, shall be done at the expense of the Contractor as part of the construction contract. The tests shall be carried out by an approved laboratory and the results given to the Borough.

3.12 ABANDONMENT OF LINES AND SERVICES:

- A. Line and services to be abandoned shall be cut free from their sources and permanently capped using a Ford Abandoned Corporation Cap to prevent leakage.

END OF SECTION

G:\BEng-Data\Projects\24-188\08 - Specification Revisions\2025 - Specification Revisions\250513 - Final\16 -02665 (Water Mains and Appurtenances).doc

SECTION 02730

MANHOLES

SECTION 02730 - MANHOLES

PART 1 - GENERAL

1.1 Related Sections:

Section 02201 - Trench Excavation and Backfill

1.2 DESCRIPTION OF WORK:

A. The work within this section includes, but is not limited to, the furnishing of all equipment, labor, materials and performing all operations necessary to construct and install precast reinforced concrete round manholes including steps and frames and covers as directed by the Authority, in accordance with Authority Specifications.

1.3 QUALITY ASSURANCE:

A. Referenced standards shall be the following:

- 1) Pennsylvania Department of Transportation (PennDOT) Publication 408, Specifications and its revisions.
- 2) American Society for Testing and Materials (ASTM).
- 3) American Association of State Highway Transportation Officials (AASHTO).

1.4 SUBMITTALS:

A. Certificates: Contractor shall submit three (3) copies of each manufacturer's certification attesting that the materials meet or exceed specification requirements.

B. Shop Drawings: Submit detail shop drawings of manholes, frames and covers, manhole steps, manhole joint sealing material, and flexible watertight gaskets prior to the start of work for approval in accordance with Section 01300.

PART 2 - MATERIALS

2.1 GENERAL:

A. Materials for construction of manholes shall be new and unused and shall conform to the following.

1) Precast Reinforced Concrete Manhole Bases, Risers, Cones or Flat Slab Tops:

- a. Concrete and steel reinforcement used in the manufacture of precast manhole bases, risers, cones and flat slab tops shall conform to

ASTM C478 (latest revision). Type II cement shall be used in the construction of the manhole components.

- b. Cone sections shall be eccentric.
- c. Provide four 3/4-inch diameter, threaded inserts for the frame hold down bolts. The inserts shall be cast into the top sections at the manufacturer's plant. Coordinate locations of inserts between the manhole manufacturer and the frame and cover manufacturer.
- d. Through-wall lifting holes are not permitted. Provide factory installed lifting keys or lugs cast integrally in manhole components.
- e. The entire outer surface (including the bottom of the structure) shall be coated with bitumastic to a minimum thickness of 20 mils. The manhole sections shall be precoated at the factory, however, the Contractor shall be required to complete any patching due to damage during installation. Xypex Admixture C-1000 may be used as an alternative to bitumastic coating.
- f. All new manholes to which force mains or low-pressure lines discharge and a minimum of four (4) manholes downstream to a linear distance of 1,600 feet (whichever is greater) shall be lined as described below.

2) PVC Coated Precast Reinforced Concrete Manhole Bases, Risers, Cones or Flat Slab Tops:

- a. PVC Liner system
 - I. PVC Coated Manholes shall be as manufactured by A-Lok Products, Inc. or pre-approved equal. The interior plastic liner for the precast manholes shall be Dura Plate 100. The Dura Plate 100 liner, when installed, shall provide a continuous, impermeable lining which will shield the precast concrete manhole against deterioration caused by corrosive material. The PVC Coated Manholes shall also meet all of the requirements specified for standard precast concrete manholes.
 - II. The design of the liner shall insure that it will conform to the contour of the manhole and form a permanent mechanical bond to the concrete through use of preformed horizontal ribs. The liner will be formed in such a manner that the joints between the manhole sections will be afforded protection through the use of a continuous PVC return into the joint for a minimum $\frac{3}{4}$ of an inch. Provisions will be made to allow the pipe openings to be sealed.

- III. The liner shall be manufactured from Polyvinyl Chloride resin and shall be white in color. The compound will result in a semi-rigid material suitable for thermoforming to the contour of the manhole. The liner may be fabricated in panels with the panels joined together by a slotted strip of EDPM rubber according to the manufacturer's specifications. All plastic liner sections shall be free of cracks, pinholes or other defects adversely affecting the protective characteristics of the material and shall have a minimum thickness of 65 mils.
- IV. The Dura Plate 100 liner will be installed during the precasting process in accordance with the specific instructions of the manufacturer.
- V. The manhole manufacturer shall provide installation instructions to each contractor prior to initial use of the Dura Plate 100 liner. The manhole will be installed using a joint sealing material as later specified.
- VI. The joint sealing material shall be placed on the joint surfaces as recommended by the manufacturer, to provide a watertight seal by filling the annular cavity, while providing sufficient squeeze-out between the PVC returns to protect against corrosion.
- VII. Flexible, corrosion-resistant, watertight connections between manhole castings and precast concrete cones or flattops shall be installed for all PVC coated manholes. This connection shall be accomplished by Water-Lok Connectors, as manufactured by A-Lok Products, Inc., or approved equal. The connector shall allow flexibility in reaching finished grade and permit up and down movement to accommodate freeze/thaw conditions close to the ground surface without compromising watertightness. This shall be accomplished by utilizing two independent, corrosion-resistant PVC sleeves which telescope within each other to allow adjustment to the correct grade. A seal is created between the two independent sleeves by a system of neoprene o-rings. The top and bottom flanges of the Water-Lok Connector are sealed to their appropriate mating surfaces by a preformed butyl gasket material furnished with the assembly. The Bolt Fastening Assembly shall be an anti-floating assembly.
- VIII. All interior concrete surfaces not covered by the PVC liner, including the flow channel, bench, and grade rings, shall be coated with Raven 405 Epoxy or approved equal. Coating of the base shall overlap the liner by a minimum of 2-inches.

b. HDPE/PP-R Liner System

- I. Liner shall be AGRU Sure Grip® CPL system with HDPE/PP-R with a minimum thickness of 2 mm (0.0787 inch) as furnished by Terre Hill Concrete Products.
- II. All HDPE liner sheets and anchors shall be extruded during a single manufacturing process. Anchoring studs shall not be welded or mechanically attached to the liner. The minimum anchoring stud concentration shall be 39 studs per square foot. The anchoring stud shall have a pull-out resistance of 112.5 lbs/stud.
- III. Flat non-anchored liner sheet, used for overlapping joints, shall have a minimum thickness of 3 mm (0.1181 inch). The cap strip shall be capable of spanning across a maximum gap of one inch that may occur at the joint between precast sections without damage to the lining.
- IV. Manufacturer certified welders with extrusion welding equipment shall weld all final joints with extrusion welds.
- V. Physical Properties
 - a) The AGRU Sure Grip® CPL systems and welding rod shall be manufactured from the same resins and meet the following properties:

Property	Testing Method	Units	HDPE	PP-R
Density	ASTM D792	g/cm ³	0.0945	1.78
MFI (Melt Flow Index)	ASTM D1238	g/10min	(190/5)	(190/5)
Heat Reversion (Dimensional Stability)	ASTM D1637	%	<3	<3
Yield Stress	ASTM D638	PSI	≥2175	≥2900
Elongation of yield.	ISO527-3 specimen	1B%	>10-	>12
Elongation	ISO527-3 specimen	1B%	>450	>200
Fire Classification	UL-94		94-HB	94-HB
Maximum Working Temperature		° C ° F	60 140	90 194

- b) Upon request, the manufacturer shall provide written certification that the liner meets or exceeds the requirements of this specification.

- c) Liner material shall be fitted and secured in the form prior to placing the concrete.
- d) All joints within each precast section shall be sealed by extrusion welding performed by AGRU certified welders, before shipment to the job site. Joints between precast sections shall be welded in the field by Terre Hill Concrete Products; Taylor Precast; US-Precast; or certified equal.
- e) Manhole steps shall be used. The joint between the step and liner shall be shop welded per manufacturers recommendation.

IX. Assembly

- a) The responsibility of providing a leak free precast structure rests on the utility contractor installing the lined structure. Welding cannot occur when concrete joints leak.
- b) Place only a single strip of gasket towards the exterior of the precast section joints to prevent entrapped air blowouts and oozing of the sealant on the liner surface.

X. Field Welding

- a) All welding shall be performed by AGRU certified welders in accordance with the published directives and procedures of the manufacturer. Completion of welding shall provide a monolithic concrete protective liner.
 - i. The following welding methods are acceptable:
 - Extrusion Welding (For all final welds)
 - Wedge welding
 - Butt welding
 - Hot air welding
 - ii. The joint areas shall be clean, dry, and free of oil and lubricants. The prepared edges shall be free of chips and notches detrimental to maximum fusion of the weld.
 - iii. All welded joints shall be finish welded with an extrusion weld, spark tested for leaks and visually inspected.

- Y. All interior concrete surfaces not covered by the HDPE liner, including the flow channel and grade rings, shall be coated with Raven 405 Epoxy or approved equal. Coating of the base shall overlap the liner by a minimum of 2-inches.

- c. Manhole Base Liner (New Manholes):
 - I. The manhole base liner shall be a Geneva Pipe and Precast Manhole Base Liner as manufactured by Geneva Pipe and Precast or approved equal. The Manhole Base Liner liner shall be of one-piece construction and of unlayered homogeneous fiberglass reinforced plastic (F.R.P.). The base liner shall provide (1) full flow channels with side walls to the crown of the pipe, (2) watertight gasketed bells to suit the specific pipe and grade alignment, (3) the inner surface of the bench to have an anti-skid surface and (4) the outer surface of the liner to be aggregate coated and have steel spirals bonded to the F.R.P. It shall be integrally cast into the precast concrete manhole to the correct line and grade as indicated on the drawing.
 - II. Installation of the Base liner in precast concrete manhole bases shall be in accordance with the manufacturer's specifications.
- d. Existing Manholes: All existing manholes to which force mains or low-pressure lines discharge, and a minimum of four (4) manholes downstream to a liner distance of 1,600 feet (whichever is greater) shall be lined as described below.
 - I. Liner shall be Alternative Lining Technologies, LLC CIPM 58 lining system with a minimum thickness of 150 mills installed.
 - II. The liner shall be installed on the interior of the manhole, including the manhole bench and shall extend 3" into the flow channel. All interior surfaces not covered by the liner, including the flow channel and grade rings, shall be coated with Raven 405 Epoxy or approved equal. Coating shall overlap the liner by a minimum of 2-inches.
 - III. The liner sealer shall be Splash Zone A-788, as manufactured by Carboline.
 - IV. Manufacturer and 20-year warranty of the lined manholes shall be approved by the Authority before lining is undertaken.
- e. Concrete: Composition and compressive strength conforming to ASTM C478 except use Type II cement in manhole components and increase compressive strength to 4,000-psi (at 28 days) in precast bases.

- I. Openings in precast concrete manholes to accommodate the connections of piping shall be custom preformed for each manhole at the time of manufacture. Openings for connection of the piping shall be of the size and shape required for the particular type of seal provided.
 - II. All precast concrete manholes shall be designed to accommodate AASHTO highway load class HS-20.
 - III. The tops of the precast bases shall be accurately formed to receive the tongue of the bottom precast concrete manhole section of the wall.
 - IV. Precast top sections shall have hold down bolt inserts factory cast in the top section. Each top shall have four (4) three quarter (3/4) inch threaded inserts or slotted inserts to accommodate manhole frame hold down bolts. Insert types designed for an ultimate load in tension of 12,500 pounds. Coordinate insert locations in the top section to match the bolt hole locations on the manhole frame. All inserts shall be factory plugged before shipping.
- f. Monolithic Poured-In-Place Concrete Bases:
- I. Monolithic poured-in-place concrete bases shall be of the design dimensions indicated on the Detail Drawings.
 - II. Portland cement: ASTM C150 Type II, Moderate Sulfate Resistance.
 - III. Concrete used for poured-in-place manhole bases shall be of a 4,000-psi mix design.
 - IV. Consistency: The concrete shall be of uniform consistency. The maximum allowable slump shall be 2-inches.
 - V. This strength requirement shall be verified by tests. At least one test shall be made once a day or one test per structure. A test shall consist of at least two cylinders whose 28-day compressive strengths shall be determined by an approved laboratory.
- g. Concrete used for channels inside precast manhole bases shall be of a 3,500-psi mix design with a 5/8" diameter maximum allowable aggregate size.
- I. Consistency: The mixed concrete shall be of uniform consistency. The maximum allowable slump shall be 1 inch.
 - II. Cement shall be Type II.
- h. Steel Reinforcement:

- I. Steel reinforcement used in the manufacture of precast concrete manhole bases and precast riser and top sections shall conform to the requirements specified in Section 6 of ASTM C478.
- i. Pipe Openings and Seals:
 - I. Openings shall be pre-formed during manufacturing in each base and Riser section requiring a piped opening. Each opening shall accommodate the type of pipe and pipe seal required.
 - II. Pipe opening seals shall meet the requirements specified in ASTM C923.
 - III. Pipe opening seals integrally cast with holes for pipe in precast concrete manhole walls shall be all-rubber composition, flexible, pliable, and provide up to 15 degrees lateral, diagonal, or vertical pipe deflection. Gaskets shall be leak proof tested to 20 psi, and shall meet or exceed rubber quality standards of ASTM C-443.
 - IV. Pipe opening seals not cast with holes for pipe shall be pliable and permit deflection. A strong rubber coated steel center compression ring and a long rubber sleeve with a deep groove secured stainless steel clamp shall be used to create a positive seal.
 - V. Rubber adapter ring for use on PVC pipe in poured-in -place manhole bases shall be recommended by the manufacturer.
 - VI. Manhole adapters shall be provided for all PVC pipe in cut-in pipe opening sand shall be recommended by the pipe manufacturer.
- j. Frame Hold Down Bolts:
 - I. Bolts, nuts, and washers shall be stainless steel in accordance with ASTM A307 and ASTM A276.

2.2 MANHOLE JOINT SEALING MATERIAL:

- A. Joints between manhole sections shall be provided with double preformed joint sealing material such as ConSeal CS-102B, or approved equal. The chemical composition of the sealer shall be as follows: Hydrocarbon plastic content, ASTM D4; Inert Mineral Filler, AASHTO T111-42; Volatile Matter, ASTM D6.

2.3 FLEXIBLE WATERTIGHT GASKETS:

- A. Bases shall have flexible watertight gaskets at the point of entry of sewer pipe into the manhole. The rubber materials shall conform to ASTM C443. The gaskets

shall be cast into the manhole base to become an integral part of the concrete. The gaskets shall be Presswedge II as manufactured by Press-Seal Gasket Corporation, Dura-Seal II as supplied by Terre Hill Concrete Products, or equivalent.

- B. Cutting of openings in precast manholes in the field will only be permitted where authorized by the Authority, and these openings shall be of proper size as required for the installation of a gasket type waterstop. Non-shrink grout shall be tightly placed into the annular space from both the inside and outside of the wall in such a manner as to completely fill the annular space and provide a watertight installation.

2.4 STANDARD FRAME AND COVER:

- A. Manhole frame and cover shall be of cast grey iron with self sealing cover as manufactured by EJ, cover model 1480AGS, product number 00148122 and frame model 1480Z, product number 00148015 or approved equivalent, machined and having the words "SANITARY SEWER" cast approximately in the center of the cover. Frames shall be securely attached to the top of the manhole section by four stainless steel anchor bolts at 180-degrees C to C. Gray iron castings shall be manufactured from iron conforming to ASTM A48, Class 35B, as noted in section 3.1 of AASHTO M306. Joint material between the frame and manhole or grade ring shall be as specified in Manhole Joint Sealing Material. Manhole frame shall be specified to accommodate the manhole lid and the manhole insert. The top of the manhole lid shall not extend above the frame.
- B. All standard frames and covers shall also include a high-density polyethylene manhole insert meeting the requirements of ASTM D-1248, Class A, Category 5, with a finish thickness of 1/8-inch as manufactured by Parson Environmental Products, Inc. All manhole inserts shall utilize a relief valve manufactured of polypropylene ethylene compound and shall be corrosion and wear resistant, and capable of releasing gas pressure at approximately 1 pound per square inch. Manhole inserts shall have a closed cell neoprene or cross-linked polyethylene gasket installed upon the insert rim by the manufacturer. The Contractor shall provide exact measurements to ensure that the manhole inserts are manufactured to fit the manhole frame rim upon which the manhole cover rests. Manhole inserts shall also include a corrosion resistant nylon strap installed for easy removal and re-installation into the manhole frame.

2.5 WATERTIGHT FRAME AND COVER:

- A. Watertight frame and cover shall be of cast grey iron as manufactured by EJ frame and cover model 1040APT 1045ZPT, product number 00104687 or approved equivalent, machined and having the words "SANITARY SEWER" cast approximately in the center of the cover. Lid shall be held in place using four stainless steel hexhead cap screws counter sunk into the lid. Frame shall be

securely attached to the top of the manhole section by four stainless steel anchor bolts at 180-degrees C to C. Gray iron castings shall be manufactured from iron conforming to ASTM A48, Class 35B, as noted in section 3.1 AASHTO M306. Joint material between the frame and manhole shall be as specified in Manhole Joint Sealing Material.

2.6 MANHOLE ENCAPSULATING SYSTEM:

- A. Contractor shall provide WrapidSeal or approved equal at all precast sanitary sewer manhole to riser ring and manhole frame joint. At the discretion of the Authority, the precast manhole joints may also require the WrapidSeal system.
- B. Manhole encapsulating system uses a heat shrinkable, wraparound sleeve to create a barrier to water infiltration and to protect manhole support structure joints from ground moisture inflow and infiltration, corrosion prevention and freeze-thaw damage from soil movement.
- C. Material: Irradiated and cross-linked polyethylene impermeable backing, coated with protective heat-activated adhesive. Material shall be provided in bulk rolls either 12-inch or 18-inch in width to provide sufficient overlap of structural joints to be sealed.
- D. Physical properties of heat shrink sleeves:
 - 1) System Type: High Shrink
 - 2) Nominal Thickness (as applied): 125 mils
 - 3) Fully Recovered Thickness: 141 mils
 - 4) Stretch Ratio: 70%
- E. Sleeve backing tensile strength: 2900 psi
- F. Primer: WrapidSeal Primer or approved equal

2.7 MANHOLE STEPS:

- A. Contractor shall provide reinforced plastic, or approved equivalent, manhole steps for manholes.
- B. Manhole steps shall be installed at the manufacturer's plant. Installation of manhole steps in the field shall not be permitted. Manhole steps shall be aligned vertically and spaced a maximum distance of 12 inches apart. The top step shall be 9" – 12" below the top of the precast structure.
- C. Reinforced plastic steps shall consist of 1/2-inch diameter deformed steel reinforcing bar completely encapsulated in polypropylene plastic. Reinforcing steel bar shall be Grade 60 as per ASTM A615 and the encapsulation material as per ASTM D2146-82, Type II, Grade 43758.

2.8 PRECAST CONCRETE MANHOLE GRADE RINGS:

- A. Concrete manhole grade rings for leveling units shall be full circle and shall be manufactured as per ASTM C-478 and shall be as thick as necessary to provide the required grade adjustment. Each grade ring shall have two holes cast therein at the manufacturer's plant for the manhole frame hold down bolts. Joint material between grade rings shall be as specified in Manhole Joint Sealing Material. No more than (2) grade rings shall be used for elevation adjustment.
- B. Rubber Grade Rings:
- 1) Rubber grade rings (rubber adjustment riser) for leveling units shall comply with the following:
 - a. Density:
 - 1) As specified in ASTM C 642-90.
 - b. Durometer Hardness:
 - 1) As specified in ASTM D 2240.
 - c. Compression:
 - 1) As specified in ASTM D 575.
 - d. Compression Set:
 - 1) As specified in ASTM D 395.
 - e. Freeze and Thaw:
 - 1) As specified in ASTM C 672-91.
 - f. Coefficient of Thermal Expansion:
 - 1) As specified in ASTM C 5314-85.
 - g. Weathering (70 hours at 70°C):
 - 1) As specified in ASTM D 573-88.
 - 2) Rubber grade rings shall only be used in paved areas.
 - 3) Tapered rubber grade rings shall be used to accommodate sloped paved surfaces.
- C. HDPE Grade Rings
- 1) All adjusting rings shall be injection molded-recycled HDPE – as manufactured by LADTECH, Inc. or approved equal and installed as per manufacturer's recommendations.
 - 2) The adjustment rings shall be manufactured from polyethylene plastic as identified in ASTM Designation D-1248 Standard Specification for Polyethylene Plastic Molding and Extrusion Materials.
 - 3) Material properties shall be tested and qualified for usage per the ASTM Test Methods referenced above.
 - 4) The adjustments rings shall be molded from 100% recycled material.

- 5) The plastic rings shall be manufactured utilizing the injection molding process as defined by the Society of Plastic Engineers.
 - 6) The adjustment rings shall be tested to assure compliance with impact and loading requirements per the ASSHTO Standard Specification for Highway Bridges.
 - 7) Installation shall be per manufacture's recommendation only.
 - 8) The annular space between the grade rings and the precast manhole top/cone and the rings and manhole frame shall be sealed using the approved butyl sealant (See Manhole Joint Sealing Material-this Section).
 - 9) All adjustment for matching road grade shall be made utilizing a molded and indexed slope ring.
- D. Chemical Grout:
- 1) Cement grout shall be non-shrink non-metallic.
 - 2) Use Type I cement where grout is not in contact with sewage.
 - 3) Use Type II (Sulfate Resistant) cement where grout is in contact with sewage.
- E. Waterproofing mortar:
- 1) Material composition meeting the requirements of ASTM C270, Type M with waterproofing admixture included.
 - 2) Apply in accordance with manufacturer's instructions.
- F. Epoxy Bonding Compound
- 1) Provide a high-modulus, low viscosity, moisture insensitive epoxy adhesive having the following characteristics.
 - a. Mix Ratio: 100 percent solids, two components; mixed one part by volume component B to two parts by volume component B.
 - b. Ultimate Compressive Strength: 13,000 psi after cure at 73° F and 50 percent relative humidity determined in accordance with ASTM D695.

2.9 INSPECTION:

- A. Field Inspection: All pipe and appurtenances shall be installed and tested for defects in material and/or workmanship in the manner specified and in the presence of, and as approved by the Authority.

2.10 HANDLING OF MATERIAL:

- A. Replacement of Damaged Material: The Contractor shall replace, at their own expense, all material furnished by him and found defective in

manufacture or damaged in handling after delivery by the manufacturer. This shall include the furnishing of all materials and labor required for replacement of installed material. Any material furnished by the Authority that becomes damaged after acceptance by the Contractor shall be replaced by the Contractor at their own expense.

B. Responsibility of Safe Storage: The Contractor shall be responsible for the safe storage of material furnished by or to him and accepted by him, and intended for the work until it has been incorporated in the completed project. The interior of all pipe, fittings and other accessories shall be kept free from dirt and foreign matter at all times. All equipment and materials subject to damage from freezing shall be drained and stored in a manner which will protect them.

C. Hauling: All materials furnished by the Contractor shall be delivered and distributed at the site by the Contractor. All materials furnished by the Owner shall be picked up by the Contractor at points designated by the Authority and hauled to and distributed at the site.

Pipe, fittings, items of equipment, and other materials of construction shall be loaded and unloaded by lifting with hoists or skidding to avoid shock or damage. Under no circumstances shall such materials be dropped. Materials handled on skidways shall not be skidded or rolled against materials already on the ground.

D. At Site of Work: In distributing the material at the site of the work, each piece shall be unloaded opposite or near the place where it is to be laid in the trench, or as otherwise directed by the Authority. Under no circumstances should lawns, grass plots or other private property be used for this purpose without the consent of the property owner.

PART 3 - CONSTRUCTION

3.1 GENERAL:

A. Manholes shall, in all cases, be fully and completely built and fitted with their frames and covers as the work progresses. Manholes shall be constructed in accordance with the following.

1) Excavation and Backfill: Excavation and backfill shall conform to the applicable requirements of Section 02201 and to the following:

a. Excavations for manholes shall be made to a vertical plane 1 foot outside the walls of the manhole. Rigid type pavement if encountered shall be cut to a rectangular shape whose sides do not exceed more than 2 feet of the diameter of the manhole base.

b. Spaces outside the manhole shall be backfilled with acceptable material in uniform layers not exceeding 12-inches in depth.

- 2) Precast Concrete Bases: All precast concrete bases shall be installed on a layer of crushed stone which shall have a minimum depth of 6 inches. The crushed stone shall conform to the quality and grading requirements specified in Section 703.3 of PennDOT Publication 408, Specifications for 1B, Type C crushed stone aggregate.
 - a. Where rubber gasket pipe seals used for connecting pipe sewer piping to precast concrete bases are of a type in which an annular space remains on the interior and exterior of the wall of the base after the pipe connection has been made, these annular spaces shall be completely filled with preformed plastic sealing compound. The sealing compound shall be tightly caulked into the annular spaces in such a manner as to completely fill the annular spaces and provide a completely watertight installation. The sealing compound shall be trowelled smooth at the inside face of the manhole base.
 - b. A 6"x8" flanged base shall be provided for all manholes.
- 3) Concrete Channel Fill: Contractor shall use a precast invert base. Inverts shall be formed directly in the concrete channel fill of the manhole base, and shall be smooth (steel trowel finish) and accurately shaped to a semi-circular bottom conforming to the inside of the adjacent sewer sections. Changes in size and grade shall be made gradually. Changes in the direction of the sewer and entering branches shall have a true curve of as large a radius as the size of the manhole will permit. Steep slopes outside the invert channels shall be avoided.
 - a. Manhole Walls: All precast reinforced concrete riser and top sections necessary to build a completed manhole shall be furnished and the different sections shall fit together readily to permit effective jointing.
 - b. Rubber gasket joints between adjacent sections shall be carefully made in accordance with the written instructions of the manufacturer of the precast concrete manhole sections.
 - c. Preformed plastic sealing compound joints between adjacent sections shall be carefully made in accordance with written instructions of the manufacturer of the preformed plastic sealing compound. After the joints have been made, the preformed plastic sealing compound shall be trowelled smooth across the joint on the inside of the manhole wall.
 - d. Pipe connections to manhole walls shall be made in the same manner as specified hereinbefore for pipe connections to precast manhole bases.
- 4) Frames and Covers: Where required, final adjustment of frame to elevation shall be made by precast concrete manhole grade rings. All joints located between the bottom of the frame and the top manhole section shall have Manhole Joint Sealing Material. Frames for all manholes shall be bolted to

the manhole as shown on the detail drawings. Bolts, nuts and washers shall be of steel and conform to ASTM A307. Bolts shall have sufficient number of proper-sized threads for installation thereof in the insert provided in the top manhole section. The bolts shall be of such length and be provided with a sufficient number of threads above the top of the frame to properly tighten the nuts thereon.

All sanitary sewer manholes installed outside of paved areas shall have a frame and cover installed 18-inches above finished grade (unless otherwise approved by the Authority).

Manholes located in fields or directly adjacent to parking areas shall be protected with (4) manhole protection posts (See Detail 12).

3.2 ACCEPTANCE TESTS:

- A. General: Test each manhole constructed in the project by the method specified herein. If the manhole is constructed on an existing sewer where sewage flow must be maintained, the test will be waived at the discretion of the Authority. Conduct tests in presence of and to the complete satisfaction of the Engineer. Should a manhole not satisfactorily pass testing, discontinue manhole construction in the project until that manhole does test satisfactorily. Provide tools, materials (including water), equipment and instruments necessary to conduct the manhole testing specified herein.
- B. Vacuum Test:
 - 1) Vacuum Testing Equipment: Use vacuum apparatus equipped with necessary piping, control valves and gauges to control air removal rate from the manhole and to monitor vacuum. Provide an extra vacuum gauge of known accuracy to frequently check testing equipment and apparatus. Vacuum testing equipment and associated testing apparatus are subject to the Authority's approval. Provide seal plate with vacuum piping connections for inserting in manhole frame.
 - a. Prior to testing, clean manholes thoroughly and seal openings, both to the complete satisfaction of the Authority. Seal openings using properly sized plugs. Perform testing with frames installed. Include the joint between the manhole and manhole frame in the test. The Contractor may elect to make a test for their own purposes prior to backfilling. However, conduct tests of the manholes for acceptance only after backfilling has been completed. In instances where the manholes are within paving, the manholes shall not be vacuum tested until the asphalt base course has been placed.
 - 2) Vacuum Test Procedure: Perform vacuum testing in accordance with the testing equipment manufacturer's written instruction. Draw a vacuum of 10 inches of mercury and close the valves. Consider manhole acceptance

when vacuum does not drop below 9 inches of mercury for the following manhole sizes and times:

4-foot diameter	- 60 seconds
5-foot diameter	- 75 seconds
6-foot diameter	- 90 seconds
7-foot diameter	- 105 seconds

- 3) Repair and Retest: Determine source or sources of leaks in manholes failing acceptance limits. Repair or replace defective materials and workmanship, as is the case, and conduct additional manhole acceptance tests and such subsequent repairs and retesting as required until manholes meet test requirements. Materials and methods used to make manhole repairs shall meet with the Authority's approval prior to use.
- 4) Acceptance: Observations of successful testing of manholes by the Authority does not constitute acceptance of the system or any portion thereof.
 - a. Only upon final inspection by the Authority, and upon written acceptance for same, will the system or portion thereof be considered substantially completed. Upon such acceptance, the warranty period as specified for the manholes will commence.

END OF SECTION

SECTION 02731

SANITARY SEWER PIPE

SECTION 02731 - SANITARY SEWER PIPE

PART 1 - GENERAL

1.1 RELATED SECTIONS:

Section 02201 - Trench Excavation and Backfill
Section 02730 - Manholes

1.2 DESCRIPTION OF WORK:

- A. The work within this section includes, but is not limited to, the furnishing of all equipment, labor and materials and performing all operations necessary to construct all gravity sanitary sewers, including all main sewers and service connections of whatever size and type required, in accordance with the Authority Specifications.

1.3 QUALITY ASSURANCE:

- A. Referenced standards shall be the following:
1. American National Standards Institute (ANSI)
 2. American Society for Testing and Materials (ASTM)
 3. American Water Works Association (AWWA)

1.4 SUBMITTALS:

- A. Certificates: Contractor shall submit three (3) copies of each manufacturer's certification attesting that the materials meet or exceed specification requirements.
- B. Shop Drawings: Submit manufacturer's descriptive and technical product data for gravity sanitary sewer pipe and fittings prior to start of work for approval in accordance with Section 01300.

PART 2 - MATERIALS

2.1 POLYVINYL CHLORIDE PIPE (PVC):

- A. Pipe and Fittings: The pipe and fittings shall be made of virgin Type 1, Grade 1 PVC compounds as defined and described in ASTM D3034 (PSM) for Rigid Poly (Vinyl Chloride) Compounds and Chlorinated Poly (Vinyl Chloride) Compounds. Pipe wall thickness shall conform to SDR 35. Pipe and fittings shall be joined with an integral bell-and-spigot type rubber gasketed joint. Each integral bell joint shall consist of a formed bell with a single rubber gasket. Gaskets shall conform to ASTM F477.

2.2 DETECTION TAPE:

- A. Detection tape shall be a metal detectable reinforced underground utility marking tape with a 50 gauge (0.0005") solid aluminum foil core with permanent printing under a mylar layer.
- B. The detection tape shall consist of a minimum 5.0 mil (0.0005") overall thickness, coated and colored cross woven polyethylene, with no less than 2,500 lbs. of tensile break strength per 12-inch width and color coded suitable for direct burial.
- C. Detection tape shall be 2-inch width minimum.

2.3 CEMENT LINED DUCTILE IRON PIPE:

- A. Where depths of sanitary sewer pipe are 15' or greater, ductile iron pipe shall be used for the entire manhole run. Ductile iron pipe shall be in full accordance with ANSI A21.51 or AWWA C151, latest editions, for the material class or pressure designated and ANSI A21.50 or AWWA C150, latest edition, for wall thickness. All ductile iron pipe shall be lined with Protecto 401 ceramic epoxy lining or approved equal. These linings shall be applied in accordance with the manufacturer's recommendation.
- B. Minimum Thickness: The minimum thickness shall be Class 52. Pipe for railroad crossing shall be Class 56.
- C. Iron Fittings: Iron fittings shall be ductile or gray iron and be in full accordance with the standard specification set forth in ANSI A21.10 or AWWA C110, latest editions. All fittings shall be minimum Class 150 and lined with Protecto 401 ceramic epoxy lining or approved equal. These linings shall be applied in accordance with the manufacturer's recommendations.
- E. Joints: Joints shall be of the push-on type or mechanical joint type in full accordance with ANSI A21.11 or AWWA C111, latest editions, for all pipe except at changes in alignment or other conditions requiring pipe restraint or as noted on the drawings. Joints requiring pipe restraint shall be Lok-Type or TR Flex as manufactured by US Pipe; Super-Lock as manufactured by Clow; Lok-Fast as manufactured by American Pipe; Locked Mechanical Joint as manufactured by Atlantic State and Griffin; or approved equivalent. Adequate tie rods must be provided to develop full joint restraint and must extend to the adjacent fitting or joint as approved by the National Board of Fire Underwriters No. 24, "Standard for Outside Protection". Mechanical joint retainer glands shall not be used. Proposed joint restraint system shall be submitted for Authority's review and approval.

2.4 INSPECTION:

- A. Field Inspection: All pipe shall be installed and tested for defects in material and/or workmanship in the manner specified and in the presence of and as approved by the Authority.

2.5 HANDLING OF MATERIAL:

- A. Replacement of Damaged Material: Any material furnished by the Authority that becomes damaged after acceptance by the Contractor shall be replaced by the Contractor at their own expense.
- B. Responsibility for Safe Storage: The Contractor shall be responsible for the safe storage of material furnished by or to them and accepted by them, and intended for the work, until it has been incorporated in the completed project. The interior of all pipe, fittings and other accessories shall be kept free from dirt and foreign matter at all times. All equipment and materials subject to damage from freezing shall be drained and stored in a manner which will protect them.
- C. Hauling: All materials furnished by the Contractor shall be delivered and distributed at the site by the Contractor. Materials furnished by the Authority shall be picked up by the Contractor at points designated by the Authority and hauled to and distributed at the site.
 - 1. Pipe, fittings, items of equipment and other materials of construction shall be loaded and unloaded by lifting with hoists or skidding to avoid shock or damage. Under no circumstances shall such materials be dropped. Materials handled on skidways shall not be skidded or rolled against materials already on the ground.
- D. At Site of Work: In distributing the material at the site or the work, each piece shall be unloaded opposite or near the place where it is to be laid in the trench, or as otherwise directed by the Authority. Under no circumstances should lawns, grass plots or other private property be used for this purpose without the consent of the property owner.
- E. Handling of Pipe and Fittings: Proper implements, tools and facilities satisfactory to the Authority shall be provided and used by the Contractor for the safe and convenient prosecution of the work. All pipe, fittings, jointing materials, etc. shall be carefully lowered into the trench piece by piece by means of a derrick, ropes or other suitable tools or equipment in such a manner as to prevent damage to sewer line materials and/or workers and in strict accordance with the manufacturer's recommendations. Under no circumstances shall such materials be dropped or dumped into the trench.

PART 3 - CONSTRUCTION

3.1 PIPE INSTALLATION:

- A. General: All pipe shall be laid to a uniform line and grade between manholes, socket ends upgrade, with a firm and even bearing along the barrel of the pipe, close joints and smooth invert. The spigot end of the pipe is to be centered in, shoved tight, and secured against the bell or socket of the previously laid pipe.

1. The interior of each pipe shall be cleaned of all excess joint and foreign material before the next pipe is laid. The pipe shall be laid in the backfill materials as specified. Pipe laying shall commence at the lowest point and proceed up grade. At the close of each day's work and at such other times when pipe is not being laid, the open end of the pipe shall be protected with a close-fitting stopper.
 2. All pipe shall be laid to the depth shown on the drawings or to a minimum of 3'-6" below finished grade to crown of pipe.
- B. Construction Control: If grade boards are to be used, the Contractor shall provide at least three grade boards in advance of pipe laying at all times at intervals not exceeding 50 feet and stretch a line parallel with the grade line. From this line, the trench and every pipe laid shall be tested as to grade and alignment. Base lines and controlling elevations established for the construction of the work shall be preserved and kept uncovered so they can be examined at any time.
1. The use of laser equipment shall be permitted. Grade boards as specified will not be required if a laser is used.
 2. Contractor shall provide verification of grade as work progresses. Pipe not laid to proper line and grade will be removed and reconstructed at the Contractor's expense.
- C. Variations: The Authority reserves the right to vary the line and/or grade from that shown on the drawings for pipe lines and manholes when such changes may be necessary and advantageous. No claims for extra work will be allowed for changes in location or grade except as when such changes are made after trenching has been done.
- D. Pipe Clearance in Rocks: Ledge rock, boulders and large stones shall be removed to provide a clearance of at least 6 inches below and on each side of all pipe and fittings for pipes 24 inches or less in diameter, and 9 inches for pipes larger than 24 inches in diameter.
- E. The specified minimum clearances are the minimum clear distances which will be permitted between any part of the pipe and/or fitting being laid and any part, projection or point of such rock, stone or boulder.
- F. Pipes at Manholes or Other Rigid Structures: Pipe directly connected to or supported by rigid structures shall be as indicated on the drawings.
- G. Diversion of Sewage during Construction
1. Sewage flowing in existing sewer shall be temporarily plugged or diverted around or through the construction by means of by-pass pumping, fluming, or any other means acceptable to the Authority.
 2. At completion of each workday tie sewage back into existing sewer. Tie-in shall be covered so there is no visible sewage.

3. Prior to beginning work, Contractor shall have on hand all required materials necessary to accomplish the work.
 4. Contractor shall be responsible for any property damage caused by sewage handling.
- H. A minimum of 18 inches vertical separation shall be provided between the sanitary sewer pipe and any pipe crossing. If 18 inches of clearance cannot be achieved, the sanitary sewer pipe shall be encased in concrete. The concrete encasement shall extend 10 feet on each side of the pipe crossing.
- I. A minimum of 10 feet horizontal separation shall be provided between the sanitary sewer pipe and any water main.
- J. A minimum of 5 feet horizontal separation shall be provided between the sanitary sewer pipe and all other utilities (i.e. gas, electric, telecommunications, storm water, etc.).

3.2 CONCRETE CRADLE AND ENCASEMENT:

- A. Preparation: Prior to the formation of the cradle or encasement, temporary supports consisting of timber wedges and solid concrete bricks or cap blocks shall be used to support the pipe in place. Temporary supports shall have minimum dimensions and shall support the pipe at not more than two locations, one at the bottom of the barrel of the pipe adjacent to the shoulder of the socket and the other near the spigot end.
- B. Placing: After jointing of the pipe has been completed, concrete shall be uniformly poured beneath and on both sides of the pipe as shown on the details. Concrete shall be wet enough during placement to permit its flow, without excessive prodding, to all required points around the pipe surface. The width of cradle shall be such as to fill completely the trench width. In case of extremely wide trenches, concrete easement may be confined above the top of the pipe to a narrower width but in no case shall it be less than the width of trench required for the size of pipe being used.
1. Before depositing concrete, the space within the limits of the pour shall have been cleared of all debris and water. Water shall not be allowed to rise adjacent to, or flow over, concrete deposited for less than 24 hours. Concrete shall be protected from the direct rays of the sun and kept moist, by a method acceptable to the Authority, for a period of seven days or until backfilling is begun. In no case shall backfilling begin within 24 hours of the time of placing and the Engineer shall have strict control of the rate of backfilling.

3.3 DROP CONNECTIONS:

- A. The Contractor shall build drop connections where shown on the drawings, where drop in the invert is 2 feet or more, or as required by the Authority and in conformity with the detail drawings and as specified herein. Drop connections shall be of the same pipe material used to construct the main from which the drop connection is made.

3.4 SERVICE CONNECTIONS:

- A. Multiple service connections to more than one property for a building sewer is not permitted. A single sewer connection to the Authority's system for each property is required. The sewer connection, to the sanitary sewer main, is owned and maintained by the property owner.
- B. Fittings (wye branches, risers and bends) and service pipe shall be installed in strict accordance with these specifications and any and all practices and precautions required for the street sewers are equally applicable to the building connections from the sewer to the right-of-way line, or to a location designated by the Authority. The Contractor shall place a 4"x4" wooden marker at the end of each sewer lateral. The marker shall be one piece and may not be constructed from two or more smaller pieces. The marker shall extend from the lateral invert to 12 inches above grade. All service laterals shall be installed in straight runs from the dwelling/building to the sanitary sewer main, without bends or angles between cleanouts.
- C. Standpipe: In general, where the sewer is laid in trench and the depth of the invert is more than 12 feet, or elsewhere as required, service connections will enter the sewer as shown on the detail drawings for "Deep Sewer Service Connection"
- D. Plugs: The upper free ends of service connection lines and wye or tee branches and pipe outlets (when connections are not made thereto at the time the mains are laid) shall be provided with a carefully fitted plug. The type of plug used and the manner in which it is secured and braced shall be acceptable to the Authority. After installation, all plugs shall be capable of being secure and completely airtight when subjected to the test procedures specified hereinafter.

3.5 END OF PIPE TO BE PROTECTED:

- A. In all cases the mouth of the pipe shall be provided with a circular board or stopper, carefully fitted to the pipe, to prevent earth or other substances from washing into the pipe.
- B. In rock excavation, the mouth of the pipe shall be carefully protected from all blasts, and the excavation shall be fully completed at least 25 feet in advance of laying of the pipe.

3.6 STORM SEWER OBSTRUCTION:

- A. When it is necessary to construct a sanitary sewer pipe beneath an existing storm sewer pipe in a location where the vertical separation between the top of the sewer pipe and the bottom of the storm sewer pipe is 3 feet or less, the pipe sewer piping shall be encased in concrete, which encasement shall extend for a distance of not less than 10 feet on each side of the outside surface of the storm sewer piping.

3.7 TESTS:

- A. General: Contractor shall notify the Authority at least 72 hours in advance of testing for scheduling. Conduct tests in presence of and to the complete satisfaction of the Authority. Test shall include alignment, deflection, infiltration, air and TV inspection.
- B. The Contractor shall submit to the Authority for approval the detailed test procedure and list of test equipment he proposes to use prior to testing.
- C. Cleaning Prior to Tests: Before tests are conducted, clean piping including sewers, branches and service connections until free of dirt or silt or construction debris.
- D. Alignment: After the mains have been laid and backfilled, a light will be flashed between manholes or manhole locations to determine whether the alignment of the sewer is true and whether any pipe has been displaced, broken or otherwise damaged subsequent to laying. This test will again be conducted before final acceptance of the sewer. Each section (manhole to manhole) of sewer shall show a good light circle throughout its length and any and all defects shall be corrected by the Contractor, to the satisfaction of the Authority, before the work shall proceed and before acceptance of the lines.
- E. Deflection Test: Provide GO-NO-GO Mandrel and incidental equipment for Deflection Test. Mandrel to conform to following requirements:
 - 1. Cylindrical in shape with odd number of arms not less than nine, spaced evenly around the mandrel.
 - 2. Minimum 12 inches contact length of mandrel arms with pipe wall.
 - 3. Mandrel diameter ninety-five percent (95%) of inside pipe diameter.
 - 4. Conduct deflection testing no less than fifteen (15) days after section of pipe sewer main and service connection between adjacent manholes is backfilled.
 - 5. Pull mandrel through pipe section manually; powered pulling devices not permitted.
 - 6. Consider sewer line section which mandrel cannot pass through, to have more than maximum allowable deflection of five percent (5%).

F. Air Testing: The Contractor shall test each section of sewer between manholes and all laterals to the limit of this contract using low pressure air. Testing shall not be performed until all backfilling has been completed. The Contractor may, at their option, test the section of sewer for their own purposes, prior to completion of backfilling; however, the requirements of this subsection shall not be deemed to be completed until the lines have been tested after the backfilling has been completed and a duration of 15 days has passed after the pipe has been backfilled to allow for trench settlement before the air test can take place. The costs of any testing incurred prior to authorization from the Authority after backfilling has been completed shall be borne by the Contractor.

1. A minimum period of two minutes shall be provided to allow equilibrium of the air temperature with pipe wall before test readings shall commence. The rate of air loss shall be determined by measuring the time interval required for the average internal pressure to decrease by 1.0 psig.
2. The initial test pressure to be developed in the sewer and laterals shall be determined as follows:
 - a) Internal pressure in psig shall be calculated as the sum of 3.5, plus the maximum height in feet between the invert of the sewer and the existing ground surface in the section of sewer to be tested divided by 2.3. (For example, if the maximum height is determined to be 9.2 feet, the added pressure would be 4.0 psig. The initial test pressure in the sewer would then be 7.5 psig. The allowable drop would be to 6.5 psig within the time indicated elsewhere in this subsection.) In no case shall the test pressure in the sewers or laterals be greater than 10 psig or the maximum internal differential joint pressure recommended by the manufacturer of the pipe, whichever is less.
 - b) The pipe shall be considered acceptable if the air loss rate does not exceed 0.0030 cubic feet per minute per square foot of internal pipe surface when tested at the initial pressure previously defined in this subsection. The time for the air pressure to decrease 1.0 psig shall not be less than the time indicated in the following table:

Pipe Diameter	Minutes
6" - 12"	6
15" - 18"	8
 - c) If the above rates of leakage are exceeded, the Contractor shall, at their expense, determine the source of leakage and make all necessary corrections and retest.

G. Infiltration: After the air testing described in the preceding subsection has been completed by the Contractor, regardless of any indications of the test results made by the Authority, the Authority reserves the right to perform field investigations, prior to final written acceptance period specified elsewhere in these specifications, to establish the leakage of groundwater into the sewer and laterals constructed under this contract. The cost of these investigations shall be borne by the Developer/Contractor.

1. Should the leakage exceed 100 gallons per day per inch diameter per mile of pipe for any section, the Contractor shall, at the direction of the Authority, and at no cost to the Authority, perform any additional testing or corrective work required to reduce the infiltration in each manhole run from those lines installed by the Contractor to less than 100 gallons per day per inch diameter of pipe. This leakage applies to each manhole run separately and should not be construed to mean total leakage in the total system. The scope of this corrective work shall include, but not be limited to, cleaning, televising and testing the sewer and laterals to the limits installed by the Contractor, to include testing and grouting of joints, excavation and replacement of faulty or damaged portions of the work, and all final restoration.

H. Video Inspection:

1. Prior to final acceptance, the Contractor shall televise the newly installed sewer system and supply two (2) copies of the DVD to the Authority for review prior to dedication. At the discretion of the Authority, additional televising may be required prior to the expiration of the Maintenance Guaranty. Defects detected by this inspection shall be repaired by the Contractor at no cost to the Authority. Defects shall include but are not limited to line sags, pipe cracks, detected leaks, etc.
 2. Video inspection shall be in color; black and white will not be accepted.
 3. In the event that a sewer section must be excavated and repaired during televising work, the Authority may request that televised recordings of the sanitary sewer facilities be taken both before and after the repairs, and shall be included as part of the records.
- I. Acceptance: Observation of successful testing of sewers by the Authority does not constitute acceptance of the system or any portion thereof.
1. Only upon final inspection by the Authority and upon written acceptance for same will the system or portion thereof be considered substantially completed. Upon such acceptance, the warranty period as specified for the sewers will commence.
 2. The final inspection will include, but not be limited to, visual inspections, lamping of lines and air testing of lines. If, during the final inspection, any irregularities are observed, the condition must be corrected at the Contractor's expense prior to acceptance.

END OF SECTION

G:\BEng-Data\Projects\24-188\08 - Specification Revisions\2025 - Specification Revisions\250513 - Final\20-2731 (Sanitary Sewer Pipe).doc

SECTION 02733

LOW PRESSURE SANITARY SEWER

SECTION 02733 - LOW PRESSURE SANITARY SEWER

PART 1 - GENERAL

1.1 RELATED SECTIONS:

Section 02201 - Trench Excavation and Backfill
Section 02730 - Manholes

1.2 DESCRIPTION OF WORK:

- A. The work within this section includes, but is not limited to, the furnishing of all equipment, labor and materials and performing all operations necessary to construct all low-pressure sanitary sewers, including all main sewers and service connections in accordance with the Borough Specifications.
- B. All new manholes shall be lined as described below. Existing manholes to which force mains or low-pressure lines discharge to and a minimum of four (4) manholes downstream to a linear distance of 1,600 feet shall be lined or coated as described below.

1.3 QUALITY ASSURANCE:

- A. Referenced standards shall be the following:
 - 1. American Association of State Highway and Transportation Officials (AASHTO)
 - 2. American National Standard Institute (ANSI)
 - 3. American Society for Testing Materials (ASTM)
 - 4. American Water Works Association (AWWA)

1.4 SUBMITTALS:

- A. Certificates: Contractor shall submit three (3) copies of each manufacturer's certification attesting that the materials meet or exceed specification requirements.
- B. Shop Drawings: Submit manufacturer's descriptive and technical product data for pressure pipe, fittings, etc. prior to the start of work for approval in accordance with Section 01300.

PART 2 - MATERIALS

2.1 POLYVINYL CHLORIDE PIPE (PVC):

- A. Pipe Sizes 3-inches and Smaller:
 - 1. PVC pipe shall be in strict accordance with ASTM D2241, Standard Specification, latest edition, for Polyvinyl Chloride (PVC) Pressure Rated Pipe (SDR-Series).
 - 2. Pipe shall be Certain-Teed, Fluid-Tite, Integral Bell, PVC Pressure Pipe, SDR 21, working pressure of 200 psi, or approved substitution.

3. For PVC pipe, compatible PVC fittings as recommended by the pipe manufacturer, shall be used. All PVC fittings shall be of the same class as the piping.
4. Joints shall be of the push-on type in strict accordance with ASTM D3139.

B. Pipe Sizes 4-inches and Larger:

1. PVC pipe shall be in strict accordance with ANSI / AWWA C900, Standard Specification, latest edition, for Polyvinyl Chloride (PVC) Pressure Pipe Plastic Pipe and Fabricated Fittings.
2. Pipe shall be in accordance with ASTM D1784, Cell Classification 12454.
3. Fittings for 4-inch or larger diameter PVC pipe shall be mechanical joint ductile or grey iron.
4. Joints shall be of the push-on type in strict accordance with ASTM D3139.

2.2 POLYETHYLENE PIPE (PE/HDPE):

A. Pipe Sizes 3-inches and Smaller:

1. Pipe shall conform to AWWA C901, Standard for Polyethylene (PE) Pressure Pipe and Tubing, ½ In. through 3 In. for Water Service. All pipe shall be manufactured with a material specified in ASTM D 3350 by a cell classification of 44574C (TR-7) with an AWWA C901 standard PE Code of 4710. The pipe shall have a pressure class of PC 200 with an outside diameter-based dimension ratio (DR) of 11. The manufacturer shall furnish a certified affidavit attesting that all products delivered comply with the requirements of AWWA C901. All pipe shall be marked with the manufacturer's name or trademark, size, material code, pressure class, AWWA designation number, and three (3) evenly spaced green stripes. Pipe shall be supplied in standard lengths as much as possible.

B. Pipe Sizes 4-inches and Larger:

1. Polyethylene Pipe shall conform to AWWA C906, Standard for Polyethylene (PE) Pressure Pipe and Fittings, 4 In. through 65 In. for Water Works. All pipe shall be manufactured with a material specified in ASTM D 3350 by a cell classification of 44574C, PPI (TR-4) with an AWWA C906 standard PE Code of 4710. The pipe shall have a pressure class of PC 200 with an outside diameter-based dimension ratio (DR) of 11 (Iron Pipe Size). Ductile Iron pipe size will be reviewed on a case-by-case basis. The manufacturer shall furnish a certified affidavit attesting that all products delivered comply with the requirements of AWWA C906. All pipe shall be marked with the manufacturer's name or trademark, size, material code, pressure class, AWWA designation number, and three (3) evenly spaced green stripes. Pipe shall be supplied in standard lengths as much as possible.

2. PE fittings shall meet the requirements of AWWA C901 / AWWA C906 and be of the same (or higher) pressure rating as the pipe line. The manufacturer must certify that the fittings are capable of restraining PE pipe or tubing from pullout at the design pressure.
3. Pipe joints shall be of the thermal butt-fusion type made in strict compliance with ASTM D-2657 and the pipe manufacturer's recommendations. Alternatively, PE pipe may be joined by electrofusion fittings in compliance with ASTM F-1290. Documentation must be provided to show that the proposed pipe installer is properly certified/ in butt-fusion and / or electrofusion pipe joining. PE pipe segments adjacent to butt-fusion / electrofusion joints must be rigidly supported for a distance of one foot beyond the joint. Termination to pump basins, valves and fittings shall be flange assemblies.
 - A. At the discretion of the Authority, compression type fittings utilizing a totally confined grip seal and coupling nut may be utilized. Stainless steel tube stiffener insert shall be used that does not extend beyond the clamp or coupling nut.

2.3 TRACER WIRE:

- A. Double tracer wire shall be installed on all low pressure main and service lateral piping (valve pit to control panel).
- B. Tracer wire shall be a (10 AWG SOLID THHN) copper conductor with a polyvinyl chloride (PVC) insulation, over which a nylon (polyamide) jacket is applied and rated for 600 volts. Insulation and jacket shall be RoHS compliant and utilize virgin grade material. Insulation color shall meet the APWA color code standard for identification of buried utilities. Tracer wire shall be Pro-Line Safety Products or approved equal and made in the USA.
- C. Tracer wire shall extend the length of the pipe run and terminate in valves boxes, manholes, cleanouts, etc. with a minimum of two feet (2') coiled tracer wire attached under the lid of the structure (not attached to the lid of the structure).

2.4 CLEANOUTS:

- A. Cleanouts shall be constructed of PVC, SDR 21 or PE DR 11 material as indicated on the detail drawings. Ball valves shall be installed at the locations indicated on the detail drawings.

2.5 VALVES:

- A. PVC ball or plug valves shall be installed within cleanout manholes on low pressure lines at the locations indicated on the drawings. Valves installed shall be actuated with a quarter turn type hand lever.
- B. Polypropylene ball valve curb stops shall be provided on all low-pressure service connections. The curb stops shall be as manufactured by CEPEX, or approved

equivalent. Buried valves shall be actuated with an underground actuator through a cast iron valve box.

2.6 VALVE BOXES:

- A. Cast iron valve boxes shall be installed over all buried valves in accordance with AWWA C500-80.

2.7 COMBINATION AIR RELEASE/VACUUM BREAK VALVES:

- A. Combination air release/vacuum break valves shall be installed where called for on the plans. Work shall include the complete assembly with tapping saddle, shutoff valve, air release and vacuum valve, piping and fittings, all complete and ready for operation. The valve shall function automatically to release into the atmosphere both large and small amounts of air that accumulate in the pipeline. The valve shall also function to admit air into the pipeline under emergency conditions or when it is being drained. The valve shall be of a type having a stainless-steel float enclosed in the valve body with a lever for opening and closing the valve. The assembly shall neither leak nor the valve stick under service conditions. All components of the valve assembly shall be stainless steel material. The valves shall be as manufactured by A.R.I. Valves, Inc., or approved equivalent.
- B. The Contractor shall furnish the valve with shut-off valve, blow-off valve, quick disconnect couplings, and a minimum of 5 feet of hose to permit backflushing after installation without dismantling the valve.

2.8 PRECAST REINFORCED CONCRETE AIR RELEASE VALVE MANHOLES:

- A. Precast Reinforced Concrete Manhole: Manholes shall be as specified in Section 02730.
- B. Frame and Cover: Frame and cover shall be as specified in Section 02730.
- C. Manhole Steps: Steps shall be as specified in Section 02730.
- D. Precast Concrete Manhole Grade Rings: Grade rings shall be as specified in Section 02730.

2.9 INSPECTION:

- A. Field Inspection: All pipe and appurtenances shall be furnished, installed and tested for defects in material and/or workmanship in the manner specified and in the presence of and as approved by the Borough.

2.10 HANDLING OF MATERIAL:

- A. Replacement of Damaged Material: The Contractor shall replace, at his own expense, all material furnished by them and found defective in manufacture or damaged in handling after delivery by the manufacturer. This shall include the furnishing of all materials and labor required for replacement of installed material.

Any material furnished by the Borough that becomes damaged after acceptance by the Contractor shall be replaced by the Contractor at his own expense.

- B. Responsibility for Safe Storage: The Contractor shall be responsible for the safe storage of material furnished by or to them, and accepted by them, and intended for the work until it has been incorporated in the completed project. The interior of all pipe, fittings and other accessories shall be kept free from dirt and foreign matter at all times. All equipment and materials subject to damage from freezing shall be drained and stored in a manner which will protect them.
- C. Hauling: All materials furnished by the Contractor shall be delivered and distributed at the site by the Contractor. Materials furnished by the Borough shall be picked up by the Contractor at points designated and hauled to and distributed at the site.
- D. Pipe, fittings, items of equipment and other materials of construction shall be loaded and unloaded opposite or near the place where it is to be laid in the trench, or as otherwise directed by the Borough. Under no circumstances should lawns, grass plots or other private property be used for this purpose without the consent of the property owner.
- E. At Site of Work: In distributing the material at the site of the work, each piece shall be unloaded opposite or near the place where it is to be laid in the trench, or as otherwise directed by the Borough. Under no circumstances should lawns, grass plots or other private property be used for this purpose without the consent of the property owner.
- F. Care of Pipe Lining: Pipe shall be handled so the lining will not be damaged. If, however, any part of the lining is damaged, the repair shall be made by the Contractor at his expense in a manner satisfactory to the Borough.
- G. Handling of Force Main Materials into Trench: Proper implements, tools and facilities satisfactory to the Borough shall be provided and used by the contractor for the safe and convenient prosecution of the work. All pipe, fittings, valves, etc. shall be carefully lowered into the trench piece by piece by means of a derrick, ropes or other suitable tools or equipment, in such a manner as to prevent damage to sewer line materials, protective coatings and linings. Under no circumstances shall such materials be dropped or dumped into the trench.

PART 3 - CONSTRUCTION

3.1 PIPE INSTALLATION:

- A. General: All pipe shall be laid and maintained to the required lines and grades with fittings and valves at the required locations; spigots centered in bells; and all valves plumb. The pipe shall be laid in the backfill materials as specified. Pipe laying shall commence at the lowest point and proceed upgrade.
- B. Construction Control: During the installation of a force main, the pipe shall be laid at a constantly increasing grade to each high point, air release manhole or point of

discharge, as shown on the contract drawings. The Contractor shall provide sufficient construction control to assure that there are no sags or loss in grade in the force main which could tend to accumulate air other than at the high points shown on the drawings. Failure to comply with this requirement shall necessitate the Contractor to take remedial steps to correct this situation. All such costs shall be borne by the Contractor.

- C. Variations: The Borough reserves the right to vary the line and/or grade from that shown on the drawings for the pipe lines and manholes and to vary the location of fittings and valves when such changes may be necessary or advantageous. No claims for extra work will be allowed for changes in location or grade except as such changes are made after trenching has been done.
- D. Caution in Excavation: The Contractor shall proceed with caution in the excavation and preparation of the trench so that the exact location of underground structures, both known and unknown, may be determined, and he shall be held responsible for the repair of such structures when broken or otherwise damaged because of carelessness on his part.
- E. Subsurface Explorations: Whenever, in the opinion of the Borough, it is necessary to explore and excavate to determine the location of existing underground structures, the Contractor shall make explorations and excavations for such purposes. If the Contractor is required to perform additional work in making the explorations and excavations, extra compensation will be allowed for such additional work.
- F. Depth of Pipe: All pipe shall be laid to the depth shown on the contract drawings or a minimum of 4.0 feet from grade to the crown of pipe.
- G. Laying Pipe: Every precaution shall be taken to prevent foreign material from entering the pipe while the pipe is being placed in the trench. During laying operations, no debris, tools, clothing or other material shall be placed in the pipe.
- H. Precautions shall be taken to prevent dirt from entering the joint space.
- I. On low pressure lines from valve pit to valve pit, there shall be a tracer wire installed for the length of the line. The tracer wire will terminate in the valve pit with a minimum of three (3) feet of wire extended out of the top of the valve pit. The wire shall be rolled up and stored in the valve pit for future Borough use.
- J. At times when pipe laying is not in progress, the open ends of the pipe shall be closed by a watertight plug or other means approved by the Borough. This provision shall apply during the noon hour as well as overnight. If water is in the trench, the seal shall remain in place until the trench is pumped completely dry.
- K. Cutting Pipe: The cutting of pipe for inserting valves, fittings or closure pieces shall be done in a neat and workmanlike manner, without damage to the pipe to leave a smooth end at right angles to the axis of the pipe.

- L. Permissible Deflection of Joints: If deflection is required, make after joint is assembled. The amount of deflection shall not exceed 50 percent of the maximum limits as specified in the AWWA C600, latest revision.
- M. Unsuitable Conditions for Laying Pipe: No pipe shall be laid in water or when, in the opinion of the Borough, trench conditions are unsuitable.
- N. A minimum of 18 inches vertical separation shall be provided between the sanitary sewer pipe and any pipe crossing. If 18 inches of clearance cannot be achieved, the sanitary sewer pipe shall be encased in concrete. The concrete encasement shall extend 10 feet on each side of the pipe crossing.
- O. A minimum of 10 feet horizontal separation shall be provided between the sanitary sewer pipe and any water main.
- P. A minimum of 5 feet horizontal separation shall be provided between the sanitary sewer pipe and all other utilities (i.e. gas, electric, telecommunications, storm water, etc.).

3.2 JOINTS:

- A. Mechanical Joint: The spigot end of the pipe shall be centrally located in the bell so that the rubber gasket is evenly sealed. All loose rust or foreign matter shall be removed from the inside surfaces of the bell and outside surface of the spigot prior to assembly. Bolts shall be tightened uniformly with a ratchet wrench so as to effect the joint seal. The normal range of bolt torques to be applied are:

<u>Bolt Size (Inches)</u>	<u>Torque - Ft. Lbs.</u>
5/8	45 - 60
3/4	75 - 90
1	100 - 120
1-1/4	120 - 150

If effective sealing is not attained at the maximum torque indicated above, the joint shall be disassembled and reassembled after thorough cleaning.

- B. Push-On Type Joints: The joint shall be assembled as recommended by the manufacturer so as to effect the joint seal.

3.3 SERVICE CONNECTIONS:

- A. Multiple service connections to more than one property for a building sewer is not permitted. A single sewer connection to the Authorities system for each property is required.
- B. Service connections shall be made using appropriately sized PVC / HDPE tee or wye fittings and reducers.
- C. The sewer connection from the cleanout to the dwelling, including the grinder pumping station and control panel is owned and maintained by the property owner.

3.4 SETTING FITTINGS AND VALVES:

- A. General: Valves and fittings shall be set and jointed to pipes in the manner hereinbefore specified for cleaning, laying and jointing pipe.
- B. Valve Pits: A concrete valve pit shall be provided for every air release and vacuum valve meeting the requirements for a manhole as hereinbefore specified. The pits shall be constructed to permit valve repairs and afford protection to the valve and pipe from impact where they pass through the pit walls.

3.5 ANCHORAGE:

- A. Anchorage for Bends: All bends deflecting 11.25 degrees or more on mains 4 inches in diameter or larger shall be provided with restrained joints to prevent movement. Suitable metal rods shall be used only as shown on the plans or directed by the Borough. All dead-end valves shall be rodded to main line with $\frac{3}{4}$ inch threaded tie rods if a restrained joint is not utilized. Mechanical joint retainer glands shall not be used.
- B. Reaction Backing: Reaction backing shall be concrete of a mix not leaner than 1 part cement, 2 1/2 sand, 5 stone, and having a compressive strength of not less than 2,000 psi, at 28 days. Backing shall be placed between solid ground and the fitting to be anchored; the area of bearing on the pipe and on the ground in each instance shall be as shown on the plans or directed by the Borough. The backing shall, unless otherwise shown or directed, be so placed that the pipe and fitting joints will be accessible for repair.
- C. Metal Harness: Metal harness of tie rods of adequate strength to prevent movement shall be used. Steel rods or clamps shall be galvanized and painted with two coats of asphalt type paint.

3.6 CONCRETE CRADLE AND ENCASEMENT:

- A. Preparation: Prior to the formation of the cradle or encasement, temporary supports consisting of solid concrete bricks or cap blocks shall be used to support the pipe in place. Temporary supports shall have minimum dimensions and shall support the pipe at not more than two locations, one at the bottom of the barrel of the pipe adjacent to the shoulder of the socket and the other near the spigot end.
- B. Placing: After jointing of the pipe has been completed, concrete shall be uniformly poured beneath and on both sides of the pipe. Placement shall be done by the use of suitable equipment. The concrete shall be wet enough during placement to permit its flow, without excessive prodding, to all required points around the pipe surface. The width of the cradle shall be such as to completely fill the trench width. In case of extremely wide trenches, concrete encasement may be confined above the top of the pipe to a narrower width, but in no case shall it be less than the width of trench required for the size of pipe being used.

- C. Before depositing concrete, the space within the limits of the pour shall have been cleared of all debris and water. Water shall not be allowed to rise adjacent to, or flow over, concrete deposited for less than 24 hours. Concrete shall be protected from the direct rays of the sun and kept moist, by a method acceptable to the Engineer, for a period of seven (7) days or until backfilling is begun. In no case shall backfill begin within 24 hours of the time of placing and the Borough shall have strict control of the rate of backfilling.

3.7 HYDROSTATIC TESTS:

- A. Pressure Test: After the pipe has been laid and backfilled as specified, all newly laid pipe or any valves section thereof shall be subjected to a hydrostatic pressure of 150 pounds per square inch or 50 percent in excess of the normal working pressure, whichever is greater.
- B. Where any section of a main is provided with concrete reaction backing, the hydrostatic pressure test shall not be made until at least five (5) days have elapsed after the concrete reaction backing was installed. If high early strength cement is used in the concrete reaction backing, the hydrostatic pressure test shall not be made until at least two (2) days have elapsed.
- C. Duration of test shall be at least two hours.
- D. Procedures: Each section of pipe shall be slowly filled with water and the specified test pressure, based on the elevation of the lowest point of the line or section, under test and corrected to the elevation of the test gauge, shall be applied by means of a pump connected to the pipe in a manner satisfactory to the Borough. The pump, pipe connections and all necessary apparatus including gauges, shall be furnished by the Contractor. The Contractor will make all taps into the pipe, and furnish all necessary assistance for conducting the tests.
- E. Expelling Air Before Test: Before applying the specified test pressure, all air shall be expelled from the pipe. If permanent air vents are not located at all high points, the Contractor shall make the necessary taps at such points before the test is made. After the test has been completed, the Contractor shall insert plugs at the tapping points.
- F. Examination Under Pressure: Any cracks or defective pipes, fittings or valves discovered in consequence of this pressure test, shall be removed and replaced by the Contractor with sound material, and the test shall be repeated until satisfactory to the Borough.
- G. Leakage Test: A leakage test shall be conducted concurrently with the pressure test. The Contractor will furnish laboratory calibrated test gauge and measuring device, and all necessary assistance to conduct the test.
- H. Leakage Definition: Leakage is defined as the quantity of water that must be supplied into the newly laid pipe, or any valve section thereof, to maintain the

specified leakage test pressure after the pipe has been filled with water and the air expelled.

- I. Permitted Leakage: No pipe installed will be accepted until the leakage is less than the number of gallons per hour as determined by the formula:

$$L = \frac{ND(P)^{1/2}}{7400}$$

in which "L" equals the allowable leakage in gallons per hour; "N" is the number of joints in the length of pipelines tested; "D" is the normal diameter of the pipe, in inches, and "P" is the average test pressure during the leakage test, in pounds per square inch gauge. (The allowable leakage according to the formula is equivalent to 11.65 US gallons per 24 hours per mile of pipe per inch nominal diameter, for pipe in 18-foot lengths evaluated on a pressure basis of 150 psi.)

- J. Should any test of pipe laid disclose leakage greater than that specified above, the Contractor shall, at his own expense, locate, repair and replace the defective joints, pipe or fittings until the leakage is within the specified allowance.

3.8 COMMON REQUIREMENTS:

- A. Borough Presence: The Borough shall monitor the pressure and leakage tests. The Contractor shall notify the Borough of the test day at least 72 hours in advance.

If test fails to meet test requirements, the Contractor shall pay for all additional engineering personnel testing time.

- B. Weather: No testing will be authorized unless air temperature is 35 degrees F or higher.

- C. Field Joints: All field joints of fittings and valves shall be exposed and examined during pressure and leakage test.

- D. Acceptance: Observation of successful testing of force mains or manholes by the Borough does not constitute acceptance of the system or any portion thereof.

Only upon final inspection by the Borough and upon written acceptance for same will the system or portion thereof be considered substantially completed. Upon such acceptance, the warranty period as specified for the force main or manholes will commence.

If, during this final inspection, any irregularities are observed, the condition must be corrected at the Contractor's expense prior to acceptance.

END OF SECTION

G:\BEng-Data\Projects\24-188\08 - Specification Revisions\2025 - Specification Revisions\250513 - Final\22-02733 (Low Pressure Sanitary Sewer).doc

SECTION 11309

PACKAGED INDIVIDUAL GRINDER PUMP
STATIONS

SECTION 11309 - PACKAGED INDIVIDUAL GRINDER PUMP STATIONS

PART 1 - GENERAL

1.1 RELATED SECTIONS:

Section 02201 - Trench Excavation, Backfill and Restoration
Section 02733 - Low Pressure Sanitary Sewer

1.2 DESCRIPTION OF WORK:

- A. The work within this section includes, but is not limited to, the furnishing and installation of all labor and materials and performing all work necessary for complete factory-built and tested Simplex and Duplex Grinder Pump Stations, each consisting of a fiberglass or precast concrete basin, grinder pumps, control system, electrical controls and all necessary appurtenances to form a complete package system. The pumps shall be a submersible end suction centrifugal type grinder unit. For ease of serviceability, all pump motor/grinder units shall be interchangeable.

1.3 QUALITY ASSURANCE:

- A. Referenced standards shall be the following:
1. American Society of Testing and Materials (ASTM)
 2. Hydraulics Institute (HI)
 3. National Electrical Manufacturers Association (NEMA)
 4. National Electrical Code (NEC)
 5. National Fire Protection Association (NFPA)
 6. Underwriter's Laboratories (UL)
- B. Manufacturer's Qualifications: Firms regularly engaged in manufacture of packaged simplex grinder pump stations of types and sizes required, whose products have been in satisfactory use in similar service for not less than five (5) years.
- C. Codes and Standards:
1. NEC Compliance: Comply with the current version of NFPA 70 NEC as applicable to installation and electrical connections of ancillary electrical components of packaged grinder pump stations.
 2. Operational Test: Provide operational tests on pumps, motors and controls, in accordance with standards of the HI. Provide recordings of test that substantiate correct performance of equipment at design head, capacity, speed and horsepower. All tests shall be conducted in the pump manufacturer's factory.

1.4 SUBMITTALS:

- A. Product Data: Submit manufacturer's technical product data, including installation and start-up instructions, furnished specialties and accessories, and current accurate pump characteristic performance curves with selection points clearly indicated.

- B. Shop Drawings: The Contractor shall provide shop drawings for all valves, sump pit, alarm system, controls, grinder pumps and entry hatch.
 - C. Wiring Diagrams: Submit manufacturer's electrical requirements for packaged simplex and/or duplex grinder pump stations including ladder-type wiring diagrams for interlock and control wiring, clearly indicating required field electrical connections.
 - D. Maintenance Data: Submit maintenance data and parts list for each packaged simplex and/or duplex grinder pump station, control and accessory, including "trouble-shooting" maintenance guide. Include this product data, shop drawings and wiring diagrams in maintenance manual.
- 1.5 DELIVERY, STORAGE, AND HANDLING:
- A. Handle packaged grinder pump stations carefully to prevent external and internal component damage, breakage, denting or scoring of pump chamber's interior or exterior finish. Do not install damaged equipment; either replace damaged components or return unit to factory for replacement.
 - B. Comply with manufacturer's rigging and installation instructions for unloading packaged grinder pump stations, and setting them in final location.

PART 2 - PRODUCTS

2.1 ACCEPTABLE MANUFACTURERS:

- A. Subject to compliance with requirements, manufacturers offering packaged lift stations which may be incorporated in the work include, but are not limited to, Liberty Pumps, Inc. packaged sewage grinder pump system or approved substitution.

2.2 OPERATING CONDITIONS:

- A. Grinder pumps must be capable of handling materials commonly found in sanitary sewage collection systems, such as plastics, rags, grit, wood, etc. Grinder pump stations must be suitable for installation in all climatic conditions found at the job site. All piping components must be kept below frost line to protect against freezing and/or equipment damage.

2.3 PACKAGED GRINDER PUMP STATIONS:

- A. Pumps shall be manufactured in the United States utilizing domestic parts and components in its construction. The volute, seal plates and motor housing shall be constructed of high-quality ASTM class 30 minimum cast iron. The pumps shall be painted with air dry enamel. All exposed hardware shall be 300 series stainless steel. Discharge connection shall be standard 1 ¼ inch NPT in the vertical position.
- B. The pump impeller shall be of the recessed, vortex design. Pumps with standard centrifugal semi-open impeller designs shall not be acceptable. The impeller shall be of 85-5-5-5 bronze construction and machined for threading to the motor shaft.

The impeller shall be capable of being trimmed to meet specific performance characteristics.

- C. The pump shall have a three-bearing design consisting of an upper ball bearing, an intermediate ball bearing restrained for the purpose of carrying the thrust loads, and a lower bronze sleeve bearing to carry radial loads and prevent shaft deflection imposed by the pump impeller and grinder operation. Designs reducing the number of bearings will not be considered equal. The stator design must be such that it allows for easy removal from its housing for replacement. Shrink or press fits shall not be considered acceptable for stator assembly or replacement. The motor shaft shall be of 416 stainless steel. Air-filled motors shall not be acceptable.
- D. Standard residential pumps shall be 2 horsepower, and shall be capable of pumping at the following characteristics:

Max Q= No greater than 50 gpm @ 10 ft. TDH
Min Q = 10 gpm @ 90 ft. TDH
Shut-Off- Head = 105 ft. or greater

Any applications which require a grinder pumping station at flow rates or head beyond the ranges established above shall be reviewed by the Borough on a case-by-case basis.

- E. The pumps shall be designed to reduce all material found in normal domestic and light industrial sewage, including plastics, rubber, sanitary napkins and disposable diapers into a finely ground slurry.
- F. The grinder mechanisms shall consist of radial cutter threaded and locked on the motor shaft by a counter sunk washer in conjunction with a flat head cap screw, and a shredding ring containing a minimum of 15 flow passages with cutting edges. Grinding shall be accomplished by a slicing action as opposed to a chopping action. Grinder design shall be able to alternately engage cutters to require half the starting torque. The shredding ring shall be reversible to provide twice the cutting-edge life. Both the shredding ring and radial cutter shall be constructed of 440C stainless steel hardened to a minimum Rockwell C55 and shall be finish ground for a fine cutting edge. Two stage cutter mechanisms requiring external adjustment for proper clearance shall not be acceptable.
- G. The grinder shall be placed immediately below the pumping elements and shall be direct-driven by a single, one-piece, stainless steel motor shaft. The grinder assembly shall be balanced and operate without objectionable noise or vibration over the entire range of recommended operating pressures. The grinder shall be constructed so as to eliminate clogging and jamming under all normal operating conditions including starting.
- H. The grinder shall be capable of reducing all components in normal domestic sewage, including a reasonable amount of "foreign objects", such as paper, wood, plastic, glass, rubber and the like, to finely-divided particles which will pass freely through the passages of the pump and the 1¼ inch diameter discharge piping. The grinding mechanism must be capable of handling reasonable amounts of grit, often found in domestic sewage systems.

- I. The minimum effective net storage volume between pump shut-off elevation and invert of influent line shall be 150 gallons. Any applications which may require a larger storage volume shall be reviewed by the Borough on a case-by-case basis.
- J. Single phase motors shall be of the capacitor start, capacitor run design, 230-volt, single phase, 2 HP as listed above. The motor shall meet the performance requirements of a NEMA L speed-torque curve. The motor shall be constructed with the open windings operating in a sealed housing which contains clean dielectric oil for heat dissipation from the windings and for lubrication of the bearings.
- K. Protection against excessive temperature shall be provided by a heat sensor thermostat attached to the stator windings and connected in series with the contactor coil in the control panel.
- L. The pump shall be equipped with 15 feet of type SO power cable. Heat shrink tubes shall be used to connect power cord leads with motor leads. A master heat shrink tube shall be provided and filled with epoxy to seal the outer cable jacket and the individual strands to prevent water from entering the motor housing. A secondary rubber pressure grommet shall be provided as an additional sealing point and strain relief at the point of cable entry. Cable entry designs utilizing terminal boards to connect power cord leads with motor leads shall not be acceptable.
- M. Motor shall be amply rated for the head and capacity values specified, on continuous duty, without exceeding 1.0 service factor load at the minimum capacity design point, and without exceeding the motor full-service factor load at any head.
- N. Motors shall be equipped with double shaft seals to prevent leakage between the motor and pump. The seal shall consist of two Type 21 oil-lubricated rotary shaft seals in an oil-filled chamber. The materials of construction shall be carbon for the rotating faces and ceramic for the stationary faces, lapped and polished to a tolerance of one light band, with 300 stainless steel hardware, with all elastomer parts of Buna-N. A single mechanical seal or a single mechanical seal in conjunction with a lip type seal will not be acceptable.
- O. Each basin shall be equipped with a 300 series stainless steel "C" channel rail assembly(ies) to facilitate removal of the pump(s) from ground level. Stainless steel lifting chains shall be supplied with each pump for pump removal.
- P. The pump discharge shall be equipped with factory installed; gravity-operated, ball-type integral check valve built into the discharge pipe. This valve will provide a full-ported passageway when open, and shall introduce a friction loss of less than 6 inches of water at maximum rated flow. In addition, all discharge piping shall be equipped with a redundant check valve inside the pump basin to ensure maximum protection against backflow. Parts will be made of 300 series stainless steel and/or Schedule 80 PVC to ensure corrosion resistance, dimensional stability and fatigue strength. The valve operation shall provide maximum seating capability, even at a very low back pressure. A 1¼ inch bronze plug valve shall be installed in the discharge piping to provide shut-off capabilities during pump removal, and shall be

fitted with an integral stainless steel extension handle. The extension handle shall extend up to within 6 inches of the top of the basin for ease of access and operation, and shall be secured at the top of the basin with a stainless-steel bracket. The pump discharge piping within the pump basin and the discharge force main shall be connected with a 3-foot section of flexible stainless-steel piping to accommodate differential settling of the force main and the pump basin. Flexible stainless steel discharge couplings shall be made of an inner corrugated hose sheathed in an outer braid and rated for 345 psi.

- Q. The pump shall be constructed with a positively primed flooded suction configuration. As added assurance that the pump cannot lose prime even under negative pressure conditions in the discharge piping system, the design shall provide for air relief in the discharge piping in the event a negative pressure is reached in the pump station discharge piping. This will automatically close when the pump is running and open to atmosphere when the pump is off.
- R. Non-fouling wastewater level detection for controlling pump and alarm operation shall be accomplished by use of a float system. For simplex pumps, three liquid level sensors shall be provided for each pump unit to control operation of the pump and high-water alarm. For duplex pumps, four liquid level sensors shall be provided for each pump unit. The level sensors shall be mercury-type pilot duty devices mounted in a corrosion resistant polypropylene housing. A weight shall be attached to the cord above the float to hold the switch in place and prevent sharp bends in the cord. A stainless-steel float bracket shall be installed within the basin. Level controls shall be set at the elevation indicated on the plans.
- S. The control/junction box shall be located in the wet well and shall have a NEMA 6 rating to protect against accidental submersion. Conduit shall enter the junction box from below. Conduit within the basin shall be stainless steel. Float cords shall exit the side of the junction box using ½ inch tap threads with submersible plastic compression grommets. A conduit seal shall be installed outside of the basin to prevent water from entering the junction box. A flexible stainless steel conduit coupling, supplied by the pump manufacturer, shall be installed on the outside of the basin.
- T. Each simplex and duplex grinder pump station control panel shall include a NEMA 4X fiberglass enclosure. All exterior hardware of the control panel shall be stainless steel. A running time meter measuring hours and tenths of hours of operation up to 99999.9 hours shall be furnished for each pump motor indicated. This shall be a 120 VAC device operating from the control voltage by an auxiliary contact of the motor starter or other run contact. The control panel shall include circuit breaker(s) and all necessary components to accomplish proper pump and control operation including the following alarm capabilities:
 - 1. When liquid level in sewage wet-well rises above the alarm level, a visual alarm will be activated.
 - 2. Visual alarm remains illuminated until sewage in wet-well returns to normal operating level.

The visual alarm shall be an amber fluted lens mounted to the top of the enclosure in such a manner as to maintain rain proof integrity. The visual alarm lamp shall be installed utilizing a separate circuit breaker than the pump(s).

- U. Construction shall be custom molded fiberglass reinforced polyester resin with interior surface to be gel-coated from 10 to 20 mil thick to provide a smooth sealed surface. Simplex pump basins shall be 30 inches in diameter, and duplex pump basins shall be 48 inches in diameter. The wall thickness shall be sufficient to withstand a water-saturated sand load of 120 pounds per cubic foot with a safety factor of two at all depths. One 4-inch Schedule 40 PVC pipe adapter-type inlet shall be furnished and installed in coordination with the sewer lateral. The PVC pipe adapter and gasket material shall be shipped loose for field installation. An anti-flotation collar shall be provided as an integral part of the basin assembly. The collar shall extend a minimum of 3 inches on the radius of the basin.
- V. The basin cover shall be one-piece, fiberglass construction with a minimum diameter 4 inches greater than the basin. The outside surfaces shall be gel coated to provide a smooth clean surface. Covers shall be a minimum of 3/8 inch thick and shall be grass green in color. Covers shall be securely held in place by a minimum of six stainless steel bolts threaded into stainless steel inserts in the top collar of the basin.
- W. Concrete basins shall be utilized in areas subject to traffic loadings such as driveways and parking lots. Precast reinforced concrete chambers shall conform to ASTM C-478 and shall be of watertight construction. Joints between sections shall be constructed with preformed plastic joint sealing material. The exterior of the basins shall be coated with two coats of Pennsbury 32-B-4 Pennoxy-Tar, or approved equal, to a dry film thickness of 7 to 8 mils per coat.
- X. Concrete basins shall be equipped with an access frame and hatch assembly of extruded aluminum. Each cover shall be provided with a lifting handle; safety catch and locking hasp. The surface shall be of a non-skid checkered pattern. Frame and cover shall be designed to withstand H-20 traffic loads.

The top of concrete basins shall be installed a minimum of 4 inches above the surrounding paving, and a minimum of four concrete-filled steel bollards shall be installed around the basin.
- Y. All materials exposed to wastewater shall have inherent corrosion protection: i.e., fiberglass, stainless steel, PVC.
- Z. The Grinder Pump shall be free from electrical and fire hazards as required in a residential environment.
- AA. As manufacturers update or make adjustments to equipment periodically, the Authority may permit adjustments to the criteria in this section to coincide with the acceptable manufacturer.

PART 3 - EXECUTION

2.4 FACTORY TEST:

- A. Each grinder pump shall be submerged and operated for 5 minutes (minimum). Actual appurtenances and controls which will be installed in the field, shall be 100 percent factory tested. Certified test results shall be supplied by the manufacturer showing the operation of each grinder pump at three (3) different points on its curve, with the maximum pressure no less than required by the system design. The Engineer reserves the right to inspect such testing procedures with representative of the Owner, at the grinder pump manufacturer's facility.
- B. The pump manufacturer shall also perform the following inspections and tests before shipment from the factory on all pumps.
 - 1. A check of the voltage and frequency shall be made as shown on the name plate.
 - 2. A motor and cable insulation test for moisture content of insulation defects shall be made.
 - 3. A vibration test shall be run on each unit at maximum rpm with maximum velocity values not to exceed 1.0 mils peak-to-peak.
 - 4. A written report shall be provided showing the aforementioned tests have been performed in accordance with the specifications.

2.5 DELIVERY:

- A. All Grinder Pumps will be delivered to the job site, completely assembled, ready for installation. Each fiberglass grinder pump basin will have a minimum of four (4) lifting eyes to facilitate unloading if not suitable for lifting-by-lifting strap.

2.6 INSTALLATION:

- A. Backfill with excavated material approved by the Engineer and containing no soil lumps, stone, concrete, or foreign objects larger than one (1) inch in maximum dimension or with Class 1S material consisting of No.8 coarse aggregate to 6 inches below grade; then topsoil and seed top 6 inches.

2.7 START-UP AND FIELD TESTING:

- A. The manufacturer shall provide the services of qualified factory trained technician(s) who shall inspect the placement and wiring of each station, perform field tests as specified herein, and instruct the owner's personnel in the operation and maintenance of the equipment before the station are accepted. All equipment and materials necessary to perform testing shall be the responsibility of the installing contractor. This will include, as a minimum, a portable generator (if temporary power is required) and water in each basin.
- B. Upon completion of the installation, the factory-authorized technician will supervise the performance of the following test on various stations:

1. Make certain the discharge shut-off valve is fully open. In some installations, there may be a valve (s) at the street main that must also be open.
 2. Fill basin with water to level on inlet line.
 3. Verify voltage is correct and record actual readings.
 4. Turn ON pump power circuit. Alarm should light. Pump should also initiate operations. Record amperage while pump is running. Verify that alarm light turns OFF as liquid level falls below alarm point. Verify pump shuts OFF at proper liquid level.
- C. Upon completion of the start-up and testing, the manufacturer's start-up representative shall submit to the engineer the start-up authorization for describing the results of the tests performed for each of the Grinder Pump Stations. Final acceptance of the system will not occur until authorization forms have been received for each pump station tested.

PART 4 - OPERATION AND MAINTENANCE

4.1 SPARES:

- A. The manufacturer will supply one spare grinder pump with movable fittings, check valves, lifting chain, motor, complete control panel, control panel components and 1 complete float assembly for every 10 units installed.

4.2 OPERATION AND MAINTENANCE MANUALS:

- A. The manufacturer shall supply four copies of Operation and Maintenance Manuals to the Borough. Each copy shall be laminated in a plastic three ring binder and shall have a complete exploded parts list and the following service contracts:
1. An authorized repair facility (capable of motor rewinding) within 20 miles of the New Holland Borough Municipal Building.
 2. Local stocking distributor within 100 miles of the New Holland Borough Municipal Building.
 3. Factory direct contact.
- B. The manufacturer will supply a minimum of five sets of standard submittal drawings, and four copies of the operation and maintenance manuals and parts lists. The standard submittals will consist of:
1. Pump outline data;
 2. Control data;
 3. Access frame data;
 4. Typical installation guides and drawings;
 5. Technical manuals;
 6. Parts lists; and
 7. Accessory data.

4.3 WARRANTY:

- A. The pump manufacturer shall warrant each of the units being supplied to the owner against defects in workmanship and material for a period of 18 months from start-up under printed form and apply to all similar units.

END OF SECTION

\\server\vol_1\BEng-Data\Projects\24-188\08 - Specification Revisions\2025 - Specification Revisions\250513 - Final\24-11309 (Grinder Pumping Stations)-R.doc

New Holland Borough Authority
Lancaster County, Pennsylvania

Construction Details

<u>NUMBER</u>	<u>DESCRIPTION</u>
1.....	PRECAST CONCRETE MANHOLE
2.....	SAMPLING MANHOLE
3.....	PRECAST CONCRETE INSIDE DROP MANHOLE
4.....	SHALLOW MANHOLE
5.....	AIR RELEASE/VACUUM BREAK MANHOLE
6.....	TERMINAL CLEANOUT MANHOLE
7.....	VALVE AND CLEANOUT MANHOLE (TYPE 1)
8.....	VALVE AND CLEANOUT MANHOLE (TYPE 2)
9.....	VALVE AND CLEANOUT MANHOLE (TYPE 3)
10.....	<BLANK>
11.....	<BLANK>
12.....	MANHOLE PROTECTION POSTS (FIELD AREAS)
13.....	FORCE MAIN CONNECTION TO MANHOLE
14.....	MANHOLE STEP
15.....	STANDARD FRAME AND COVER
16.....	WATERTIGHT FRAME AND COVER
17.....	TYPICAL GRAVITY BUILDING SEWER CONNECTION
18.....	SHALLOW SANITARY LATERAL
19.....	DEEP SANITARY SEWER LATERAL (12' AND DEEPER)
20.....	PIPE CASING

21.....	CLEANOUT
22.....	1,000 GALLON GREASE INTERCEPTOR
23.....	1,500 GALLON GREASE INTERCEPTOR
24.....	2,000 GALLON GREASE INTERCEPTOR
25.....	SIMPLEX GRINDER PUMP STATION (FIBERGLASS BASIN-SECTION)
26.....	SIMPLEX GRINDER PUMP STATION (FIBERGLASS BASIN-PLAN)
27.....	DUPLEX GRINDER PUMP STATION (FIBERGLASS BASIN-SECTION)
28.....	DUPLEX PUMP STATION (FIBERGLASS BASIN-PLAN)
29.....	DUPLEX GRINDER PUMP STATION (CONCRETE BASIN-SECTION)
30.....	DUPLEX GRINDER PUMP STATION (CONCRETE BASIN-PLAN)
31.....	<BLANK>
32.....	TYPICAL LOW PRESSURE SEWER PROPERTY CONNECTION
33.....	GRINDER PUMP POST MOUNTED CONTROL PANEL
34.....	TYPICAL GRINDER PUMP SERVICE LINE TO LOW PRESSURE SEWER
35.....	TYPICAL LATERAL CONNECTION TO LOW PRESSURE FORCEMAIN
36.....	TYPICAL GRINDER PUMP SERVICE LINE TO GRAVITY SEWER
37.....	<BLANK>
38.....	<BLANK>
39.....	CLAY DIKE
40.....	SADDLE CONNECTION
41.....	TYPICAL THRUST BLOCKING
42.....	TYPICAL THRUST BLOCKING
43.....	TYPICAL THRUST BLOCKING
44.....	TYPICAL TRENCH
45.....	TYPICAL TRENCH BACKFILL
46.....	LAWN RESTORATION

47.....	PAVED DRIVEWAY RESTORATION
48.....	STONE DRIVEWAY RESTORATION
49.....	TEMPORARY BOROUGH ROADWAY AND SHOULDER RESTORATION
50.....	PERMANENT BOROUGH ROADWAY AND SHOULDER RESTORATION
51.....	CONCRETE ENCASEMENT
52.....	CONCRETE CRADLE
53.....	METERING MANHOLE (FORCE MAIN)
54.....	METERING MANHOLE (GRAVITY)
55.....	RECORDER MOUNTING
56.....	TYPICAL CONCRETE ANCHOR DETAIL (8" THRU 36" SEWERS)
57.....	LOW PRESSURE CLEANOUT
58.....	STANDARD DOMESTIC SERVICE INSTALLATION
59.....	FIRE HYDRANT SETTING
60.....	TYPICAL GATE VALVE & VALVE BOX
61.....	$\frac{3}{4}$ " STANDARD METER PIT, PREPIPED
62.....	1 $\frac{1}{2}$ " AND 2" STANDARD METER PIT, PREPIPED
63.....	DOUBLE WATER METER VAULT TYPE A GENERAL LAYOUT
64.....	DOUBLE WATER METER VAULT TYPE A PIPE SCHEMATIC
65.....	METER VAULT – NON-TRAFFIC HATCH
66.....	METER VAULT – TRAFFIC RATED HATCH
67.....	METER VAULT – LADDER DETAIL
68.....	METER VAULT – LATTER EXTENSION
69.....	CAP AND BLOW OFF
70.....	TAPPING VALVE AND SLEEVE

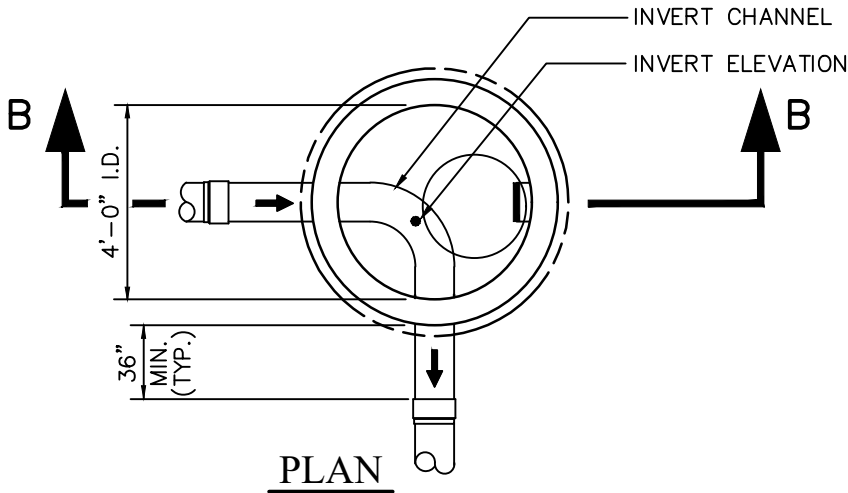

PLAN

INSTALL WRAPIDSEAL OR APPROVED EQUAL ON ALL PRECAST MANHOLE RISER RINGS AND MANHOLE FRAME JOINT (TYP.).

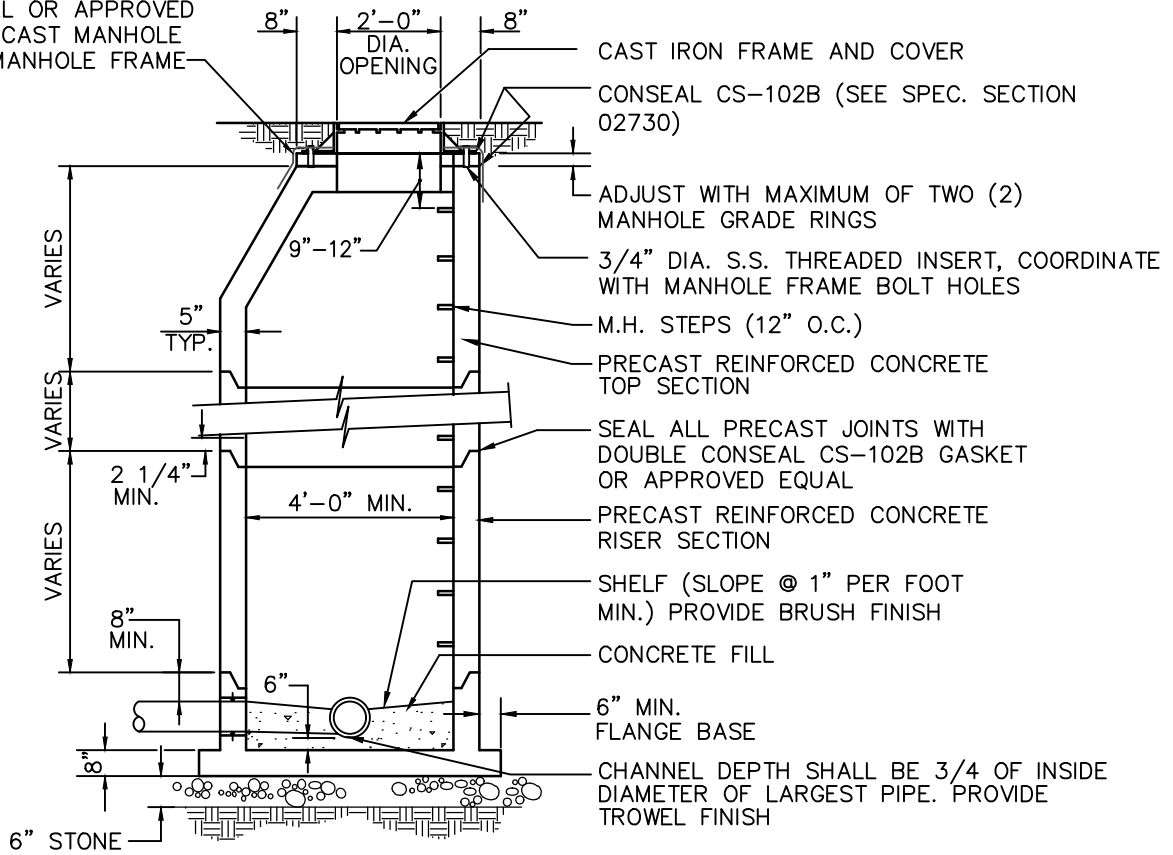

SECTION B-B

NOTES:

1. MECHANICALLY VIBRATED PRECAST CONCRETE, RISER AND TOP SHALL CONFORM TO A.S.T.M. SPEC. C-478.
2. MANHOLE SHALL HAVE 2 COATS BITUMASTIC COATING ON EXTERIOR (INCLUDING BOTTOM.) XYPEX ADMIX C-100 NF MAY BE USED AS AN ALTERNATIVE TO THE BITUMINOUS COATING.
3. MAINTAIN POSITIVE GRADE THROUGH MANHOLE.
4. ALL OPENINGS AROUND PIPES SHALL BE FINISHED WITH NON-SHRINK GROUT.
5. INTERIOR OF MANHOLE SHALL HAVE A PROTECTIVE HDPE/PVC LINER IF REQUIRED IN ACCORDANCE WITH AUTHORITY RULES AND REGULATIONS.
6. ALL EXISTING MANHOLES TO WHICH FORCE MAINS OR LOW-PRESSURE LINES DISCHARGE, AND A MINIMUM OF FOUR (4) MANHOLES DOWNSTREAM TO A LINER DISTANCE OF 1,600 FEET (WHICHEVER IS GREATER) SHALL BE LINED IN ACCORDANCE WITH SPECIFICATIONS SECTION 02730 PARAGRAPH 2.1.2.
7. ALL HARDWARE SHALL BE STAINLESS STEEL.

PRECAST CONCRETE MANHOLE

NOT TO SCALE

DATE: APRIL 2025

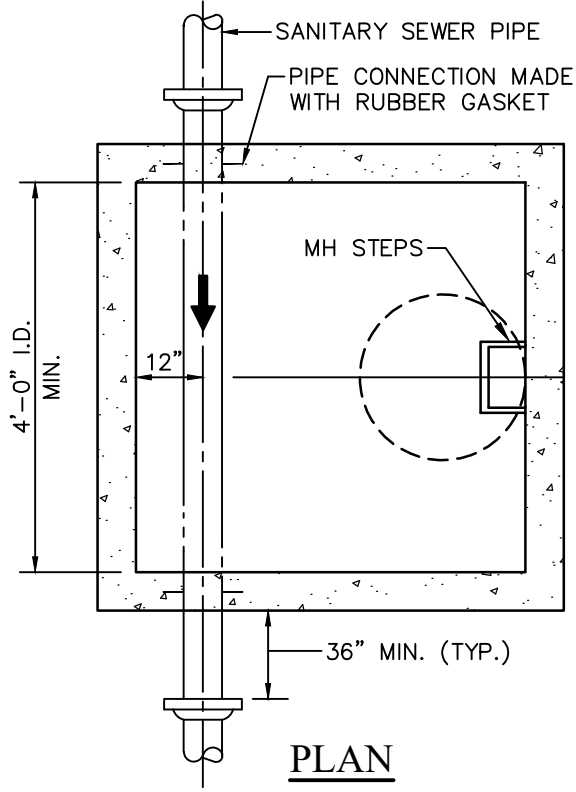

PLAN

NOTES:

1. MECHANICALLY VIBRATED PRECAST CONCRETE, RISER AND TOP SHALL CONFORM TO A.S.T.M. SPEC. C-478.
2. MANHOLE SHALL HAVE 2 COATS BITUMINOUS COATING ON EXTERIOR (INCLUDING BOTTOM). XYPEX ADMIX C-100 NF MAY BE USED AS AN ALTERNATIVE TO THE BITUMINOUS COATING.
3. MAINTAIN POSITIVE GRADE THROUGH MANHOLE.
4. ALL OPENINGS AROUND PIPES SHALL BE FINISHED WITH NON-SHRINK GROUT.
5. INTERIOR OF MANHOLE SHALL HAVE A PROTECTIVE HDPE/PVC LINER IF REQUIRED IN ACCORDANCE WITH AUTHORITY RULES AND REGULATIONS.
6. MANHOLE CHANNELS, BENCH, AND ALL INTERIOR SURFACES SUBJECT TO CORROSION SHALL RECEIVE RAVEN 405 CORROSION RESISTANT COATING SHOP DRAWINGS SHALL BE SUBMITTED FOR COATING.
7. ALL EXISTING MANHOLES TO WHICH FORCE MAINS OR LOW-PRESSURE LINES DISCHARGE, AND A MINIMUM OF FOUR (4) MANHOLES DOWNSTREAM TO A LINER DISTANCE OF 1,600 FEET (WHICHEVER IS GREATER) SHALL BE LINED IN ACCORDANCE WITH SPECIFICATION SECTION 02730 PARAGRAPH 2.1.2.
8. ALL HARDWARE SHALL BE STAINLESS STEEL.

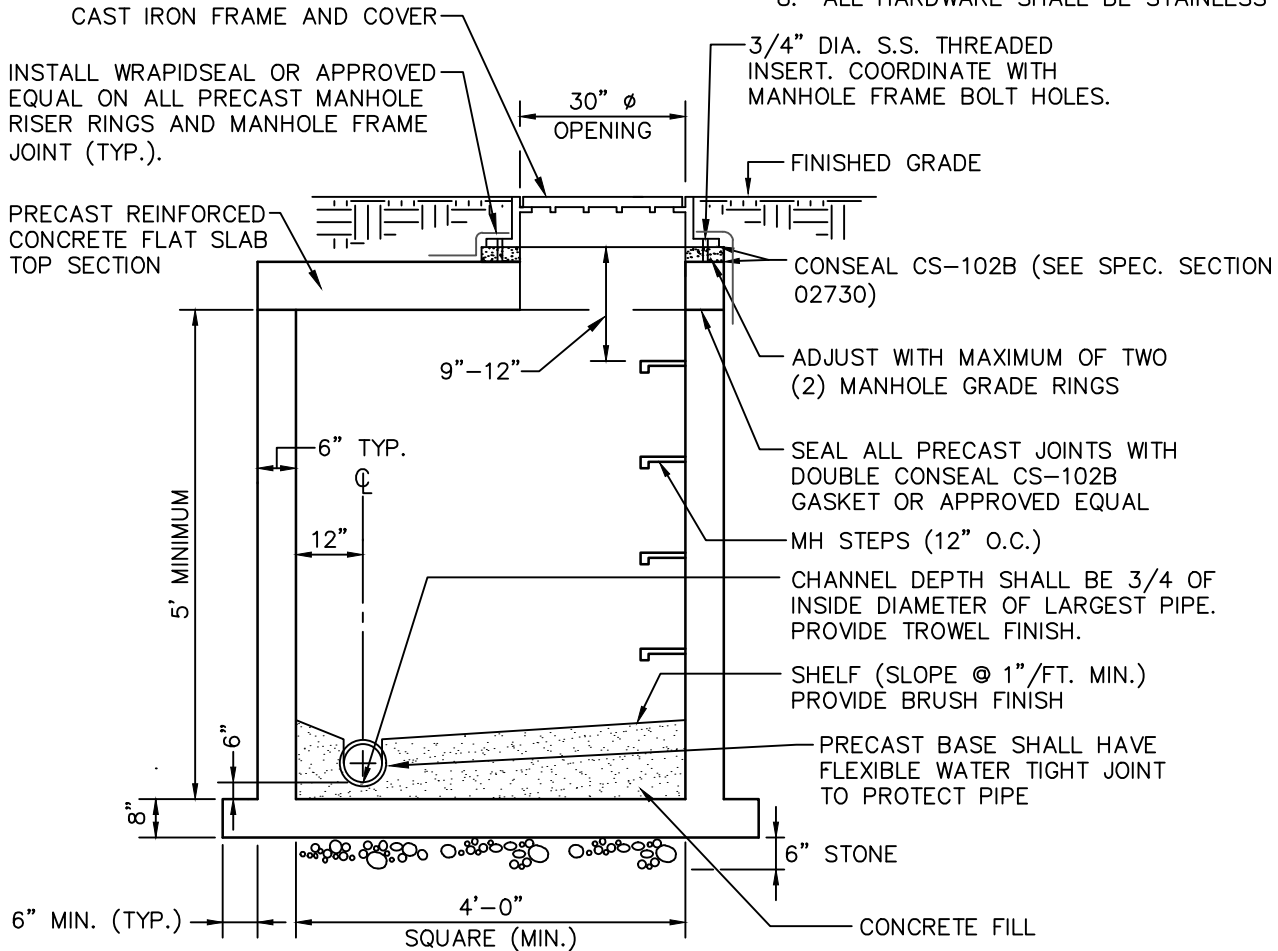

SECTION

SAMPLING MANHOLE

NOT TO SCALE

INSTALL WRAPIDSEAL OR APPROVED EQUAL ON ALL PRECAST MANHOLE RISER RING AND MANHOLE FRAME JOINT (TYP.).

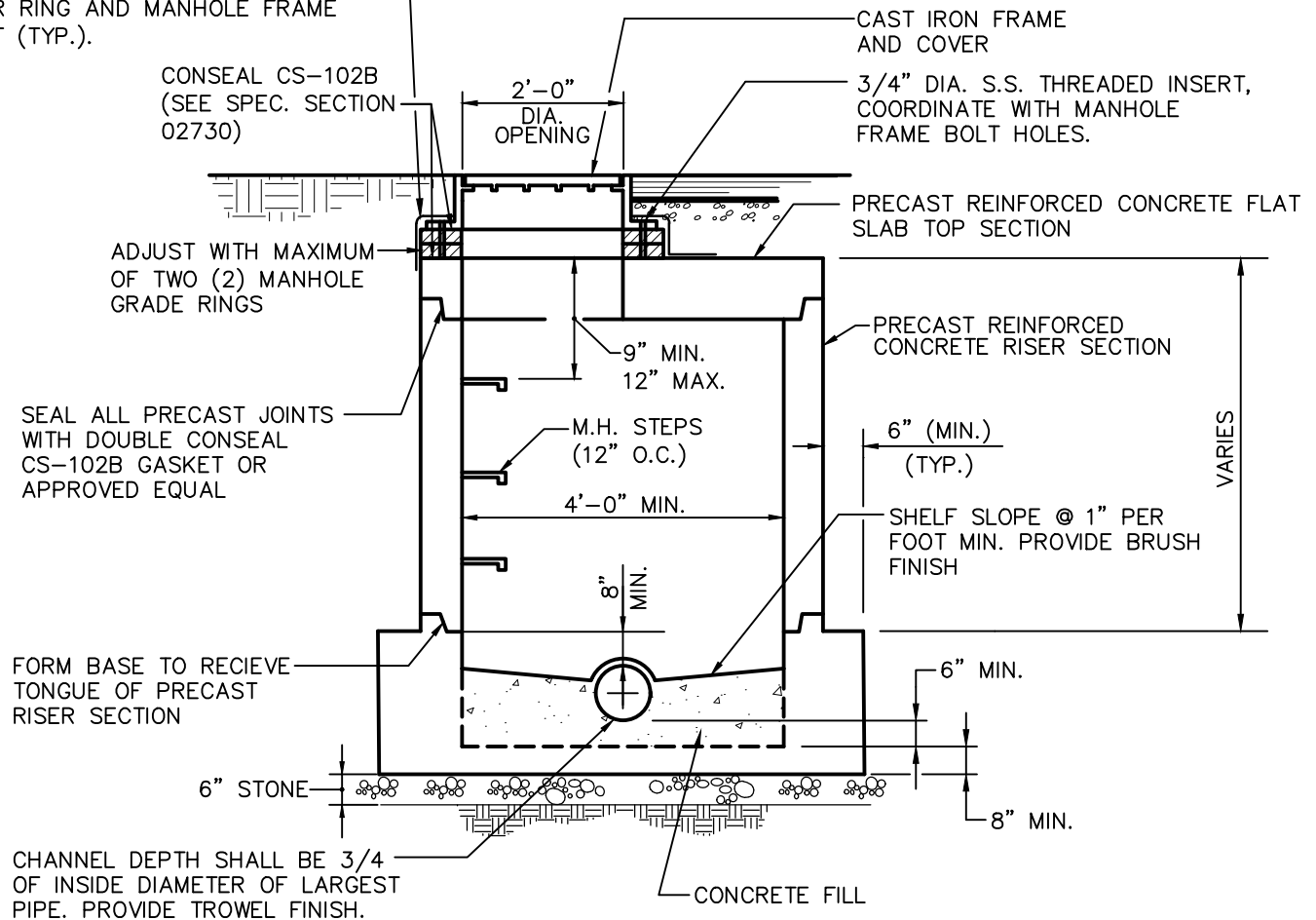

NOTES:

1. MECHANICALLY VIBRATED PRECAST CONCRETE, RISER AND TOP SHALL CONFORM TO A.S.T.M. SPEC. C-478.
2. MANHOLE SHALL HAVE 2 COATS BITUMASTIC COATING ON EXTERIOR (INCLUDING BOTTOM) XYPEX ADMIX C-100 NF MAY BE USED AS AN ALTERNATIVE TO THE BITUMASTIC COATING.
3. MAINTAIN POSITIVE GRADE THROUGH MANHOLE.
4. ALL OPENINGS AROUND PIPES SHALL BE FINISHED WITH NON-SHRINK GROUT.
5. MANHOLE CHANNELS, BENCH, AND ALL INTERIOR SURFACES SUBJECT TO CORROSION SHALL RECEIVE RAVEN 405 CORROSION RESISTANT COATING SHOP DRAWINGS SHALL BE SUBMITTED FOR COATING.
6. ALL EXISTING MANHOLES TO WHICH FORCE MAINS OR LOW-PRESSURE LINES DISCHARGE, AND A MINIMUM OF FOUR (4) MANHOLES DOWNSTREAM TO A LINEAR DISTANCE OF 1,600 FEET (WHICHEVER IS GREATER) SHALL BE LINED IN ACCORDANCE WITH SPECIFICATION SECTION 02730 PARAGRAPH 2.1.2.
7. ALL HARDWARE SHALL BE STAINLESS STEEL.

SHALLOW MANHOLE

NOT TO SCALE

NOTES:

1. MECHANICALLY VIBRATED PRECAST CONCRETE, RISER AND TOP SHALL CONFORM TO A.S.T.M. SPEC. C-478.
2. MANHOLE SHALL HAVE 2 COATS BITUMASTIC COATING ON EXTERIOR (INCLUDING BOTTOM). XYPEX ADMIX C-100 NF MAY BE USED AS AN ALTERNATIVE TO BIRUMASTIC COATING.
3. ALL OPENINGS AROUND PIPES SHALL BE FINISHED WITH NON-SHRINK GROUT.
4. ALL MANHOLE FOOTINGS TO BE UNDISTURBED EARTH W/ CRUSHED AGGREGATE UP TO PIPE INVERTS. MANHOLES TO BE OPEN TO DRAIN.
5. ALL AIR RELEASE MANHOLES SHALL BE PROVIDED WITH A HDPE/PVC LINER.
6. LOOP (24" MIN.) TRACER WIRE IN MANHOLE.

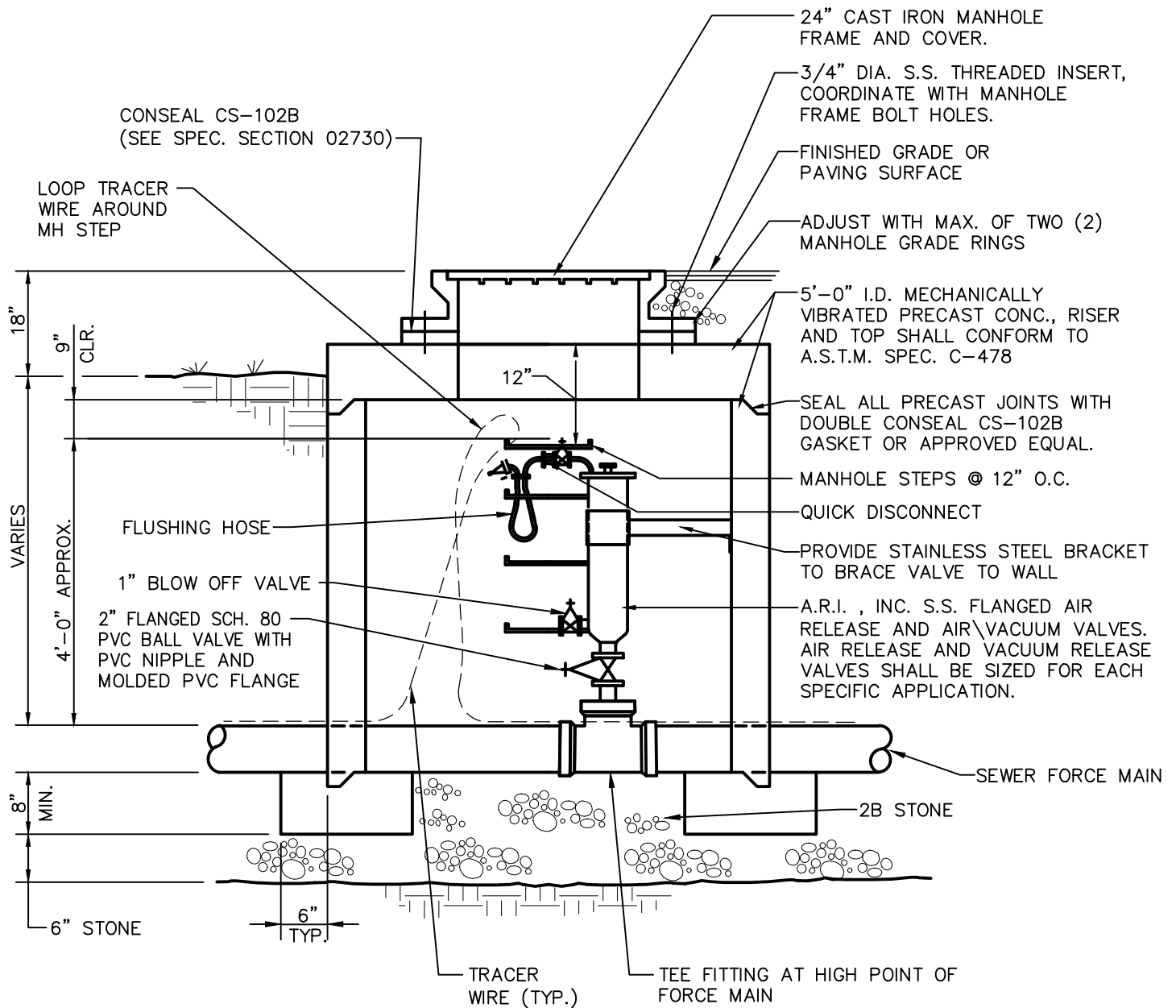

AIR RELEASE / VACUUM BREAK MANHOLE

NOT TO SCALE

NOTES:

1. MECHANICALLY VIBRATED PRECAST CONCRETE, RISER AND TOP SHALL CONFORM TO A.S.T.M. SPEC. C-478.
2. MANHOLE SHALL HAVE 2 COATS BITUMASTIC COATING ON EXTERIOR.
3. ALL OPENINGS AROUND PIPES SHALL BE FINISHED WITH NON-SHRINK GROUT.
4. ALL MANHOLE FOOTINGS TO BE UNDISTURBED EARTH W/ CRUSHED AGGREGATE UP TO PIPE INVERTS. MANHOLES TO BE OPEN TO DRAIN.

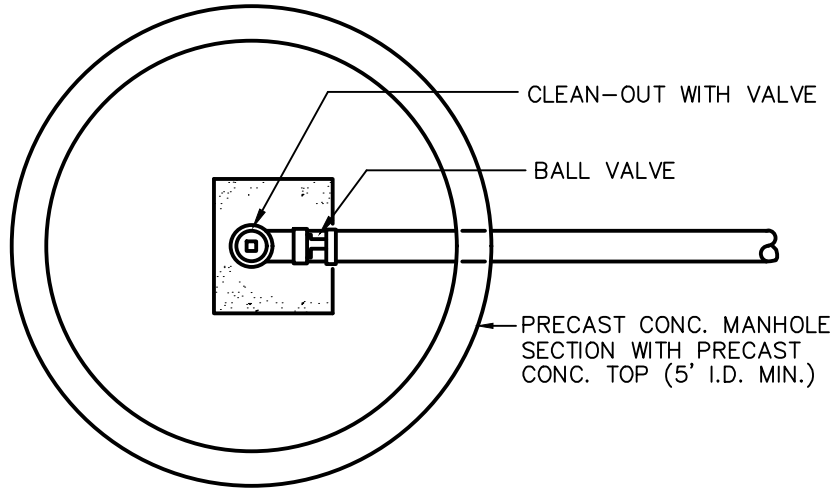

PLAN

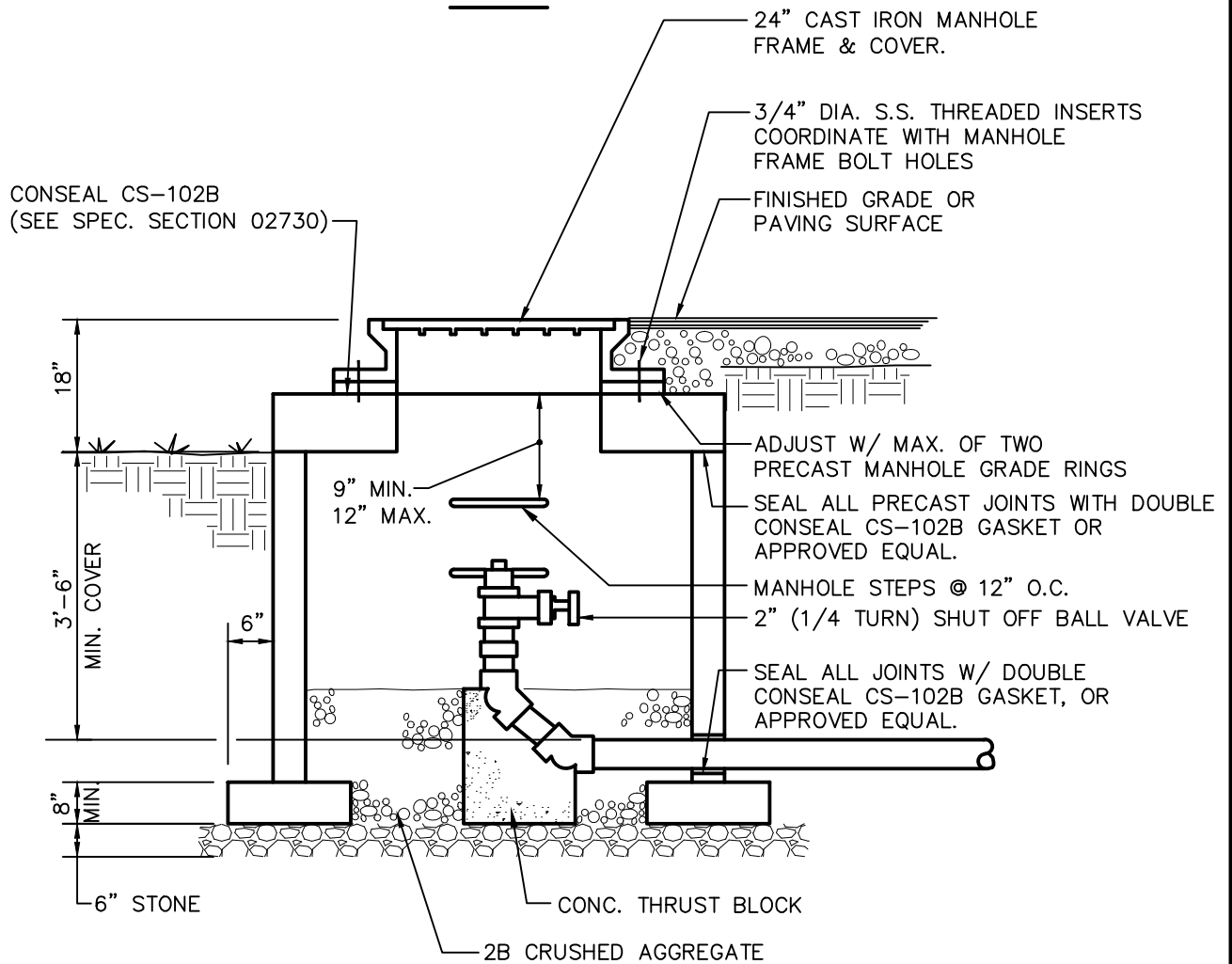

SECTION

TERMINAL CLEANOUT MANHOLE

NOT TO SCALE

NOTE: TYPE 1 MANHOLE CONFIGURATION DEPENDS ON PIPE SIZES AND ARRANGEMENTS

1. PIPE SIZES 2", 2-1/2", AND 3" SHALL USE A 5' I.D. MANHOLE (MIN.).
2. PIPE SIZE 4" AND 6" SHALL USE A 6' I.D. MANHOLE (MIN.).

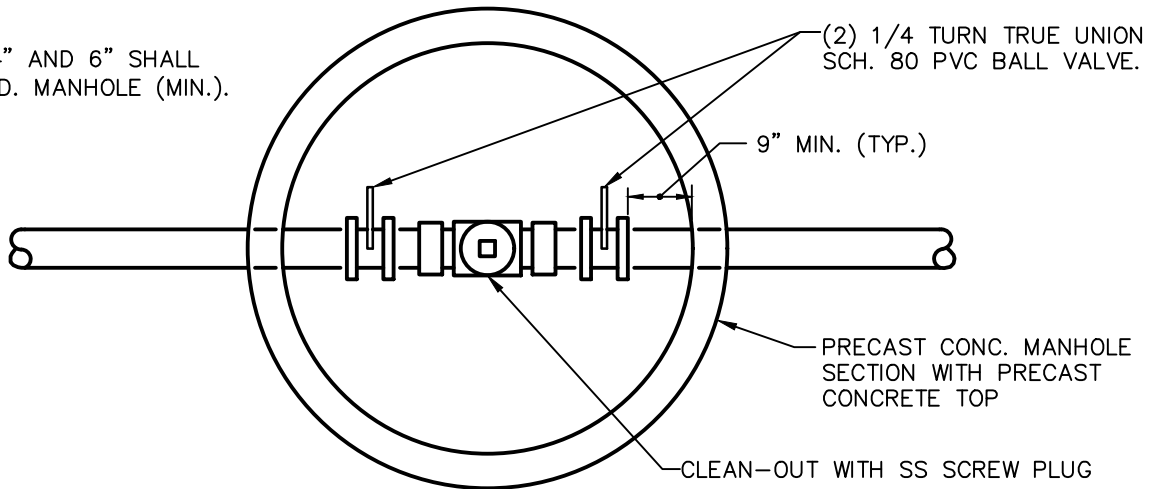

PLAN

NOTES:

1. MECHANICALLY VIBRATED PRECAST CONCRETE, RISER AND TOP SHALL CONFORM TO A.S.T.M. SPEC. C-478.
2. MANHOLE SHALL HAVE 2 COATS BITUMASTIC COATING ON EXTERIOR.
3. ALL OPENINGS AROUND PIPES SHALL BE FINISHED WITH NON-SHRINK GROUT.
4. ALL MANHOLE FOOTINGS TO BE UNDISTURBED EARTH W/ CRUSHED AGGREGATE UP TO PIPE INVERTS. MANHOLES TO BE OPEN TO DRAIN.
5. LOOP (24" MIN.) TRACER WIRE IN MANHOLE.

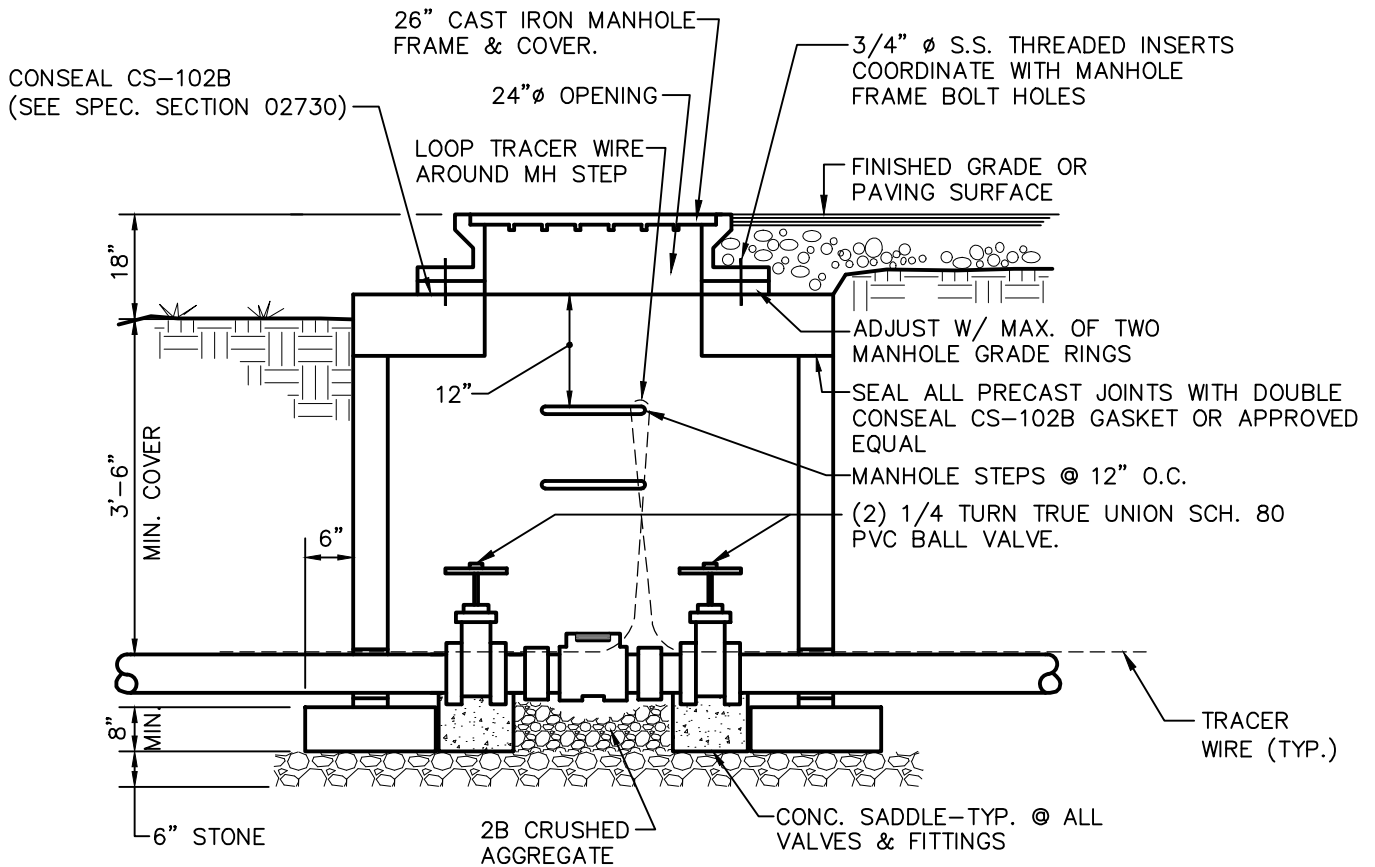

SECTION

**VALVE & CLEANOUT
MANHOLE TYPE 1**

NOT TO SCALE

NOTE: TYPE 2 MANHOLE CONFIGURATION DEPENDS ON PIPE SIZES AND ARRANGEMENTS

- 1. PIPE SIZES 2", 2 1/2", AND 3" SHALL USE A 5' I.D. MANHOLE (MIN.).
- 2. PIPE SIZE 4" SHALL USE A 6' I.D. MANHOLE (MIN.).
- 3. PIPE SIZE 6" SHALL USE A 6'x8' RECTANGULAR (INSIDE DIMENSION) MANHOLE (MIN.).

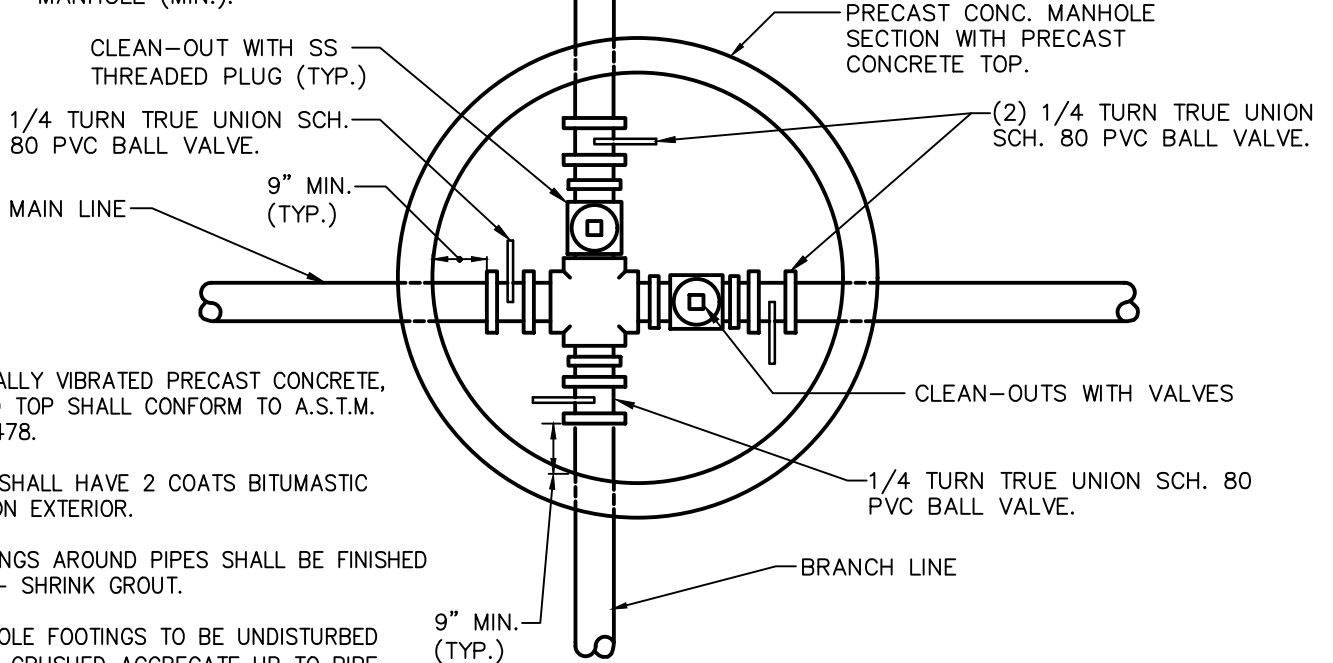

NOTES:

- 1. MECHANICALLY VIBRATED PRECAST CONCRETE, RISER AND TOP SHALL CONFORM TO A.S.T.M. SPEC. C-478.
- 2. MANHOLE SHALL HAVE 2 COATS BITUMASTIC COATING ON EXTERIOR.
- 3. ALL OPENINGS AROUND PIPES SHALL BE FINISHED WITH NON-SHRINK GROUT.
- 4. ALL MANHOLE FOOTINGS TO BE UNDISTURBED EARTH W/ CRUSHED AGGREGATE UP TO PIPE INVERTS. MANHOLES TO BE OPEN TO DRAIN.
- 5. LOOP (24" MIN.) TRACER WIRE IN MANHOLE.
- 6. 4" & 6" BRANCH LINE SHALL BE OFFSET FROM CENTERLINE ACCORDINGLY TO ACCOMMODATE MAIN LINE VALVE AND CLEAN-OUT CONFIGURATION.

PLAN

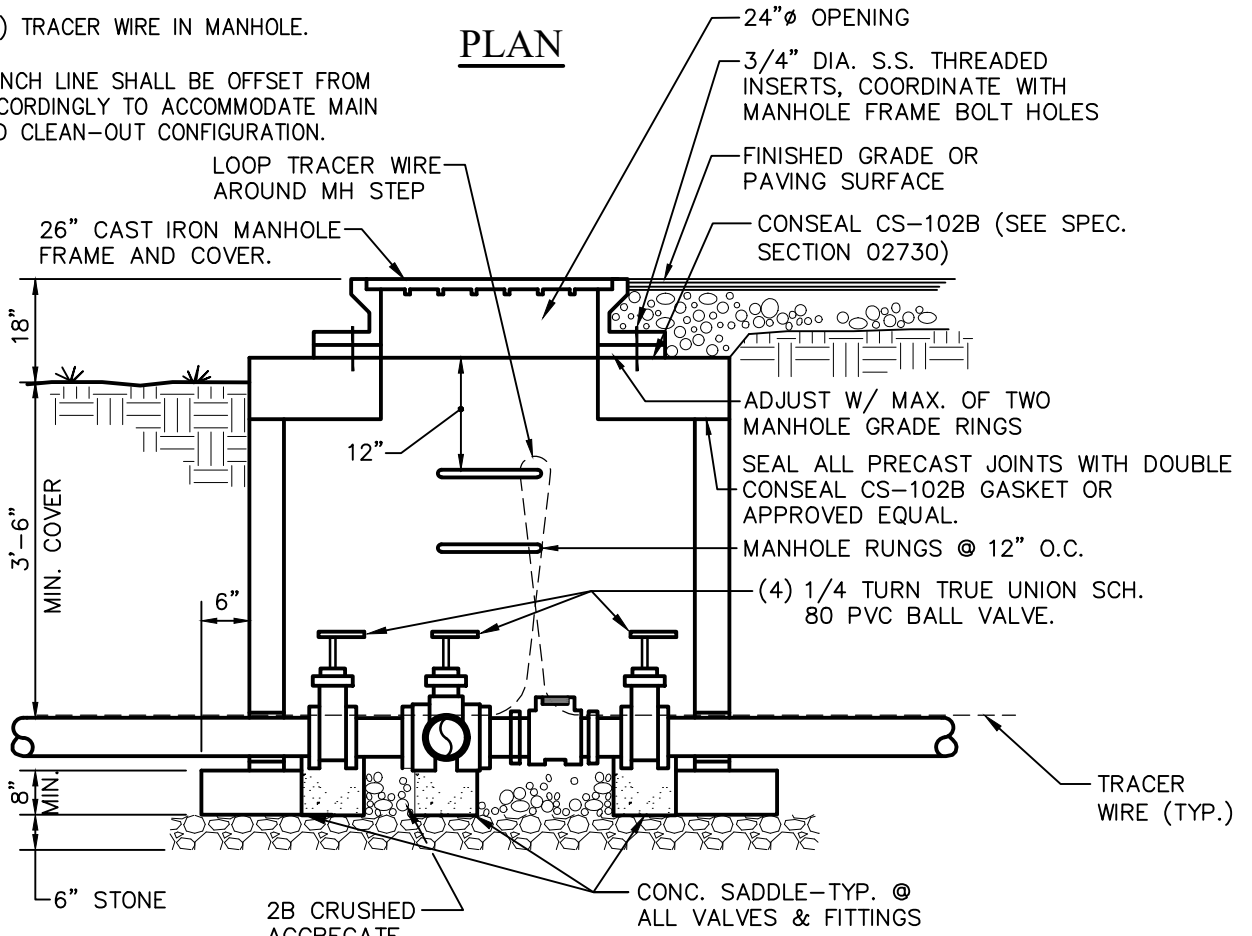

SECTION

VALVE & CLEANOUT MANHOLE TYPE 3

NOT TO SCALE

DATE: APRIL 2025

THIS PAGE INTENTIONALLY LEFT BLANK

THIS PAGE INTENTIONALLY LEFT BLANK

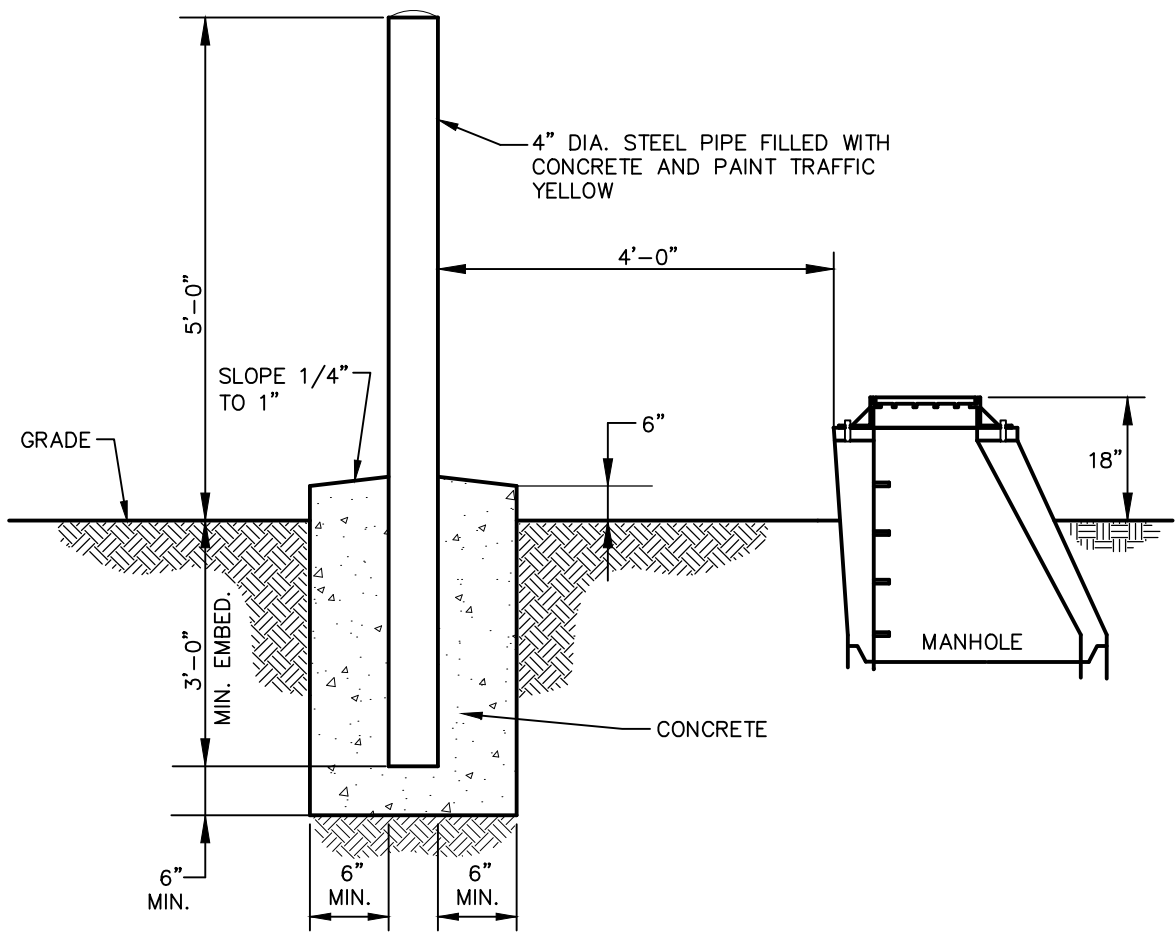

NOTES:

1. INSTALL IN FIELD AREAS OR ADJACENT TO PARKING AREAS.
2. INSTALL A TOTAL OF 4 POSTS AT EACH MANHOLE.

MANHOLE PROTECTION POSTS (FIELD AREAS)

NOT TO SCALE

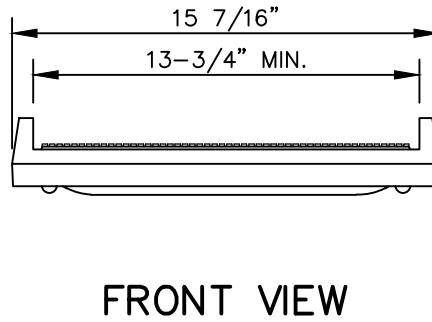
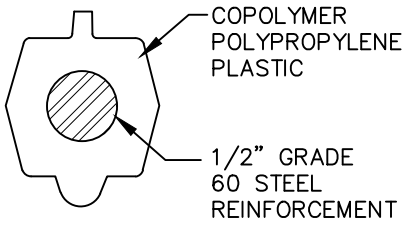
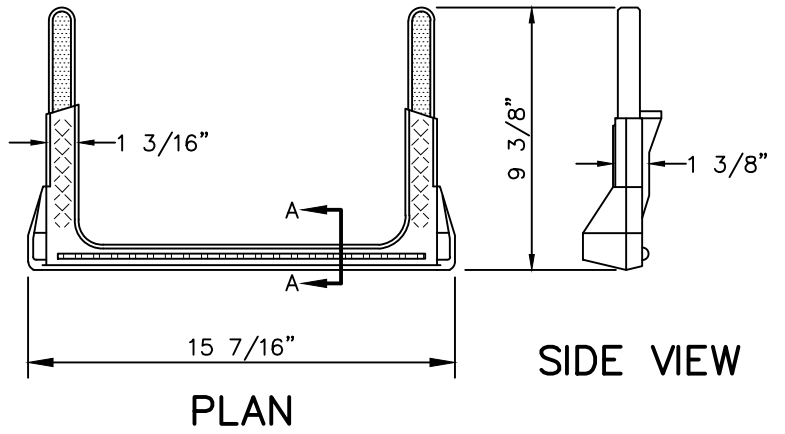
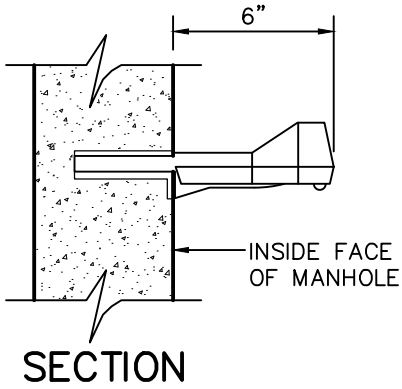

MANHOLE STEP

NOT TO SCALE

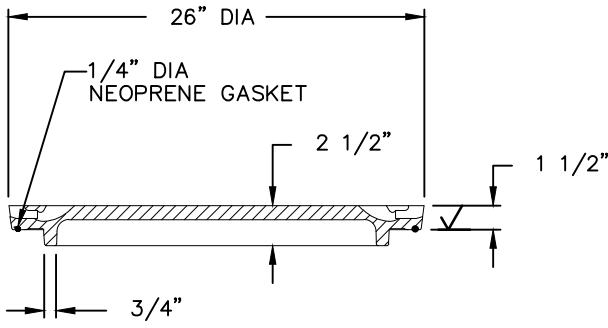
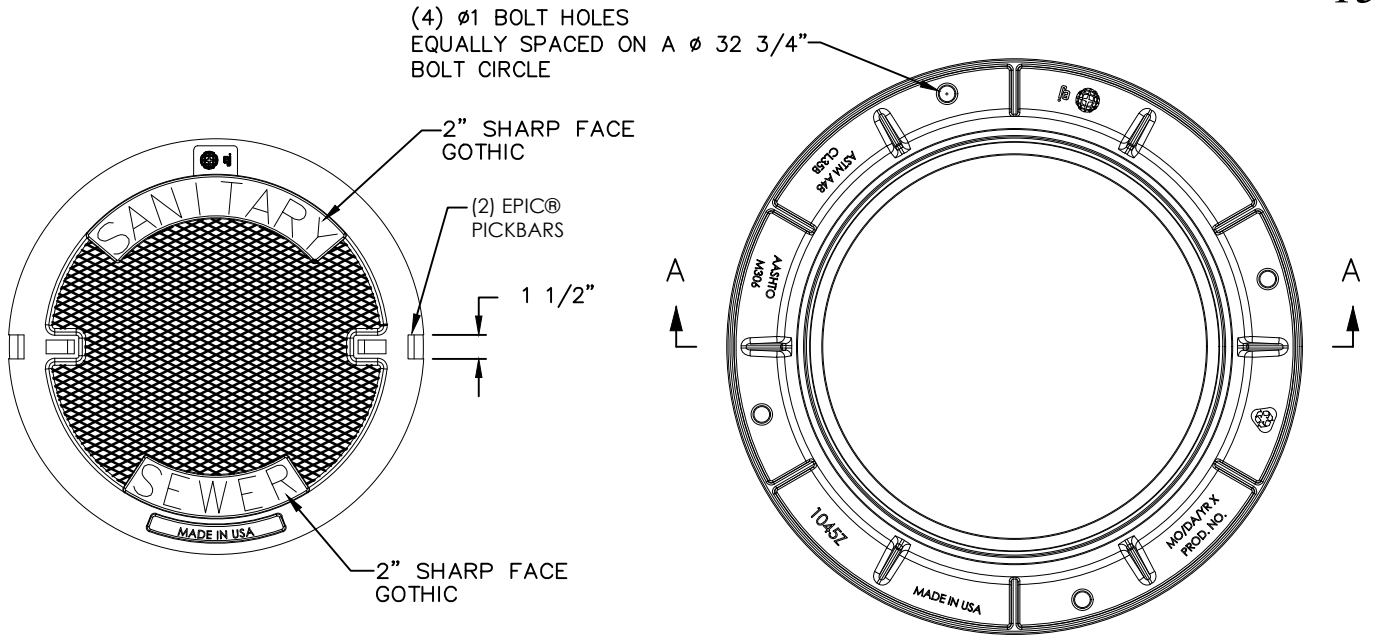

COVER SECTION

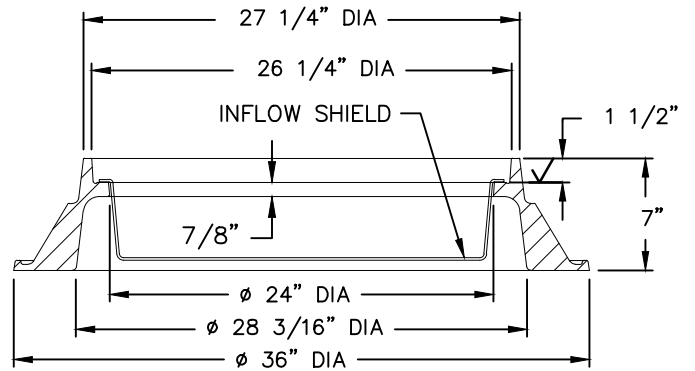

FRAME SECTION A-A

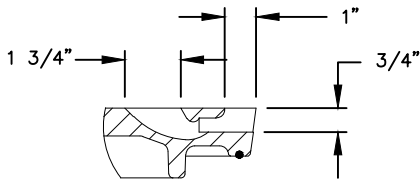

EPIC® DETAIL

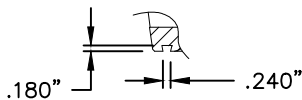

GROOVE DETAIL

NOTES

1. ALL MANHOLE FRAME AND COVER DIMENSIONS SHALL BE CONSIDERED MINIMUM, UNLESS OTHERWISE NOTED, WITH THE EXCEPTION OF THE BOLT HOLE AND CORED HOLE DIMENSIONS.
2. ALL MANHOLE FRAMES AND COVERS SHALL BE FOR HEAVY DUTY TRAFFIC.
3. ALL COVERS SHALL BE SELF SEALING.
4. ALL HARDWARE TO BE STAINLESS STEEL.
5. "WATER" SHALL BE CAST ON MANHOLE COVERS FOR USE WITH WATER FACILITIES.

STANDARD FRAME AND COVER

NOT TO SCALE

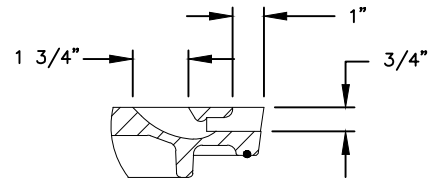
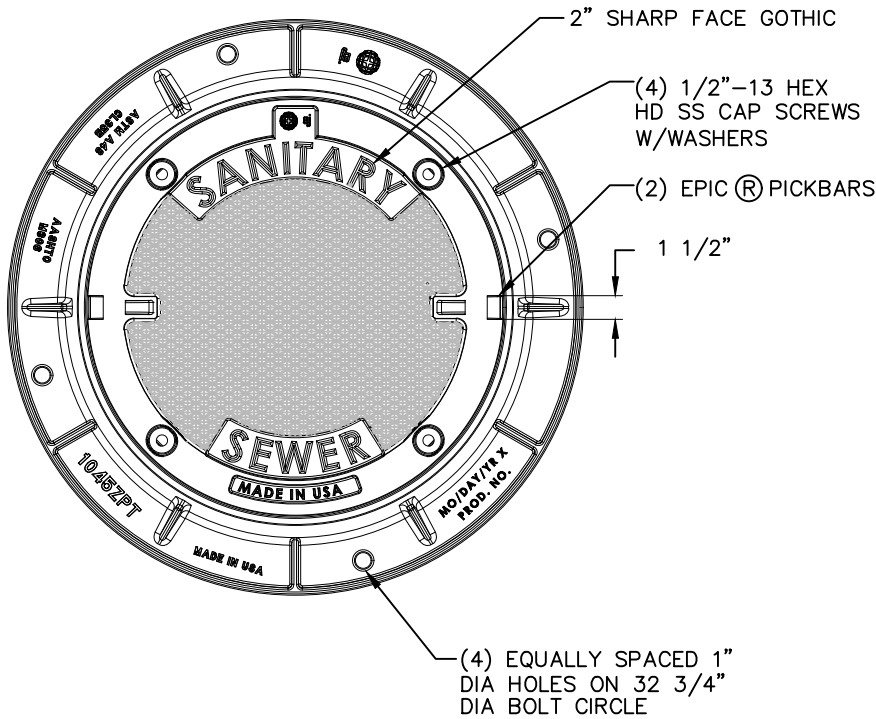

EPIC® DETAIL

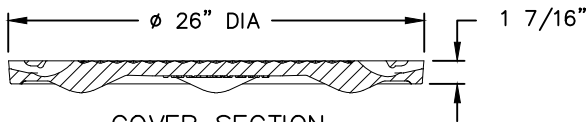

COVER SECTION

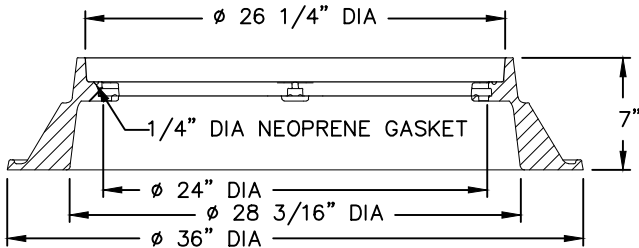

FRAME SECTION

NOTES

1. ALL MANHOLE FRAME AND COVER DIMENSIONS SHALL BE CONSIDERED MINIMUM, UNLESS OTHERWISE NOTED, WITH THE EXCEPTION OF THE BOLT HOLE AND CORED HOLE DIMENSIONS.
2. ALL MANHOLE FRAMES AND COVERS SHALL BE FOR HEAVY DUTY TRAFFIC.
3. ALL COVERS SHALL BE SELF SEALING.
4. ALL HARDWARE SHALL BE STAINLESS STEEL.
5. "WATER" SHALL BE CAST ON MANHOLE COVERS FOR USE WITH WATER FACILITIES.

WATERTIGHT FRAME AND COVER

NOT TO SCALE

NOTE: PROVIDE 6" OF AASHTO NO. 8 (OR PennDOT NO. 1B) STONE BELOW PIPE AND 12" ABOVE ENTIRE LENGTH OF PIPE.

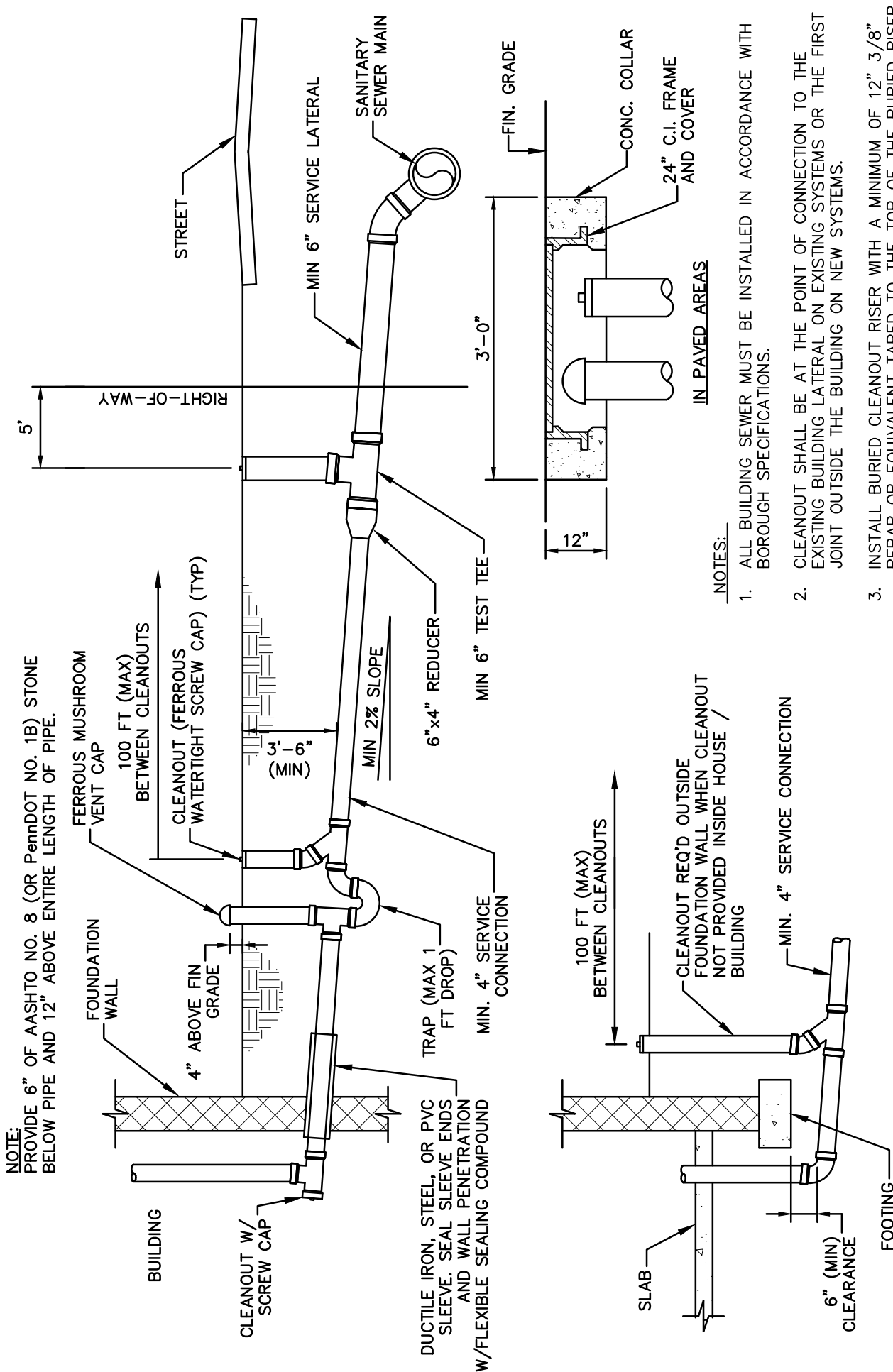

- NOTES:
1. ALL BUILDING SEWER MUST BE INSTALLED IN ACCORDANCE WITH BOROUGH SPECIFICATIONS.
 2. CLEANOUT SHALL BE AT THE POINT OF CONNECTION TO THE EXISTING BUILDING LATERAL ON EXISTING SYSTEMS OR THE FIRST JOINT OUTSIDE THE BUILDING ON NEW SYSTEMS.
 3. INSTALL BURIED CLEANOUT RISER WITH A MINIMUM OF 12" 3/8" REBAR OR EQUIVALENT TAPED TO THE TOP OF THE BURIED RISER (AFTER TESTING).
 4. CLEANOUT RISER GLUE FIT TO 6"x6"x6" TEE. (SEE DETAIL 19 FOR PRE-TESTING CONFIGURATION.)

TYPICAL GRAVITY BUILDING SEWER CONNECTION

NO SCALE

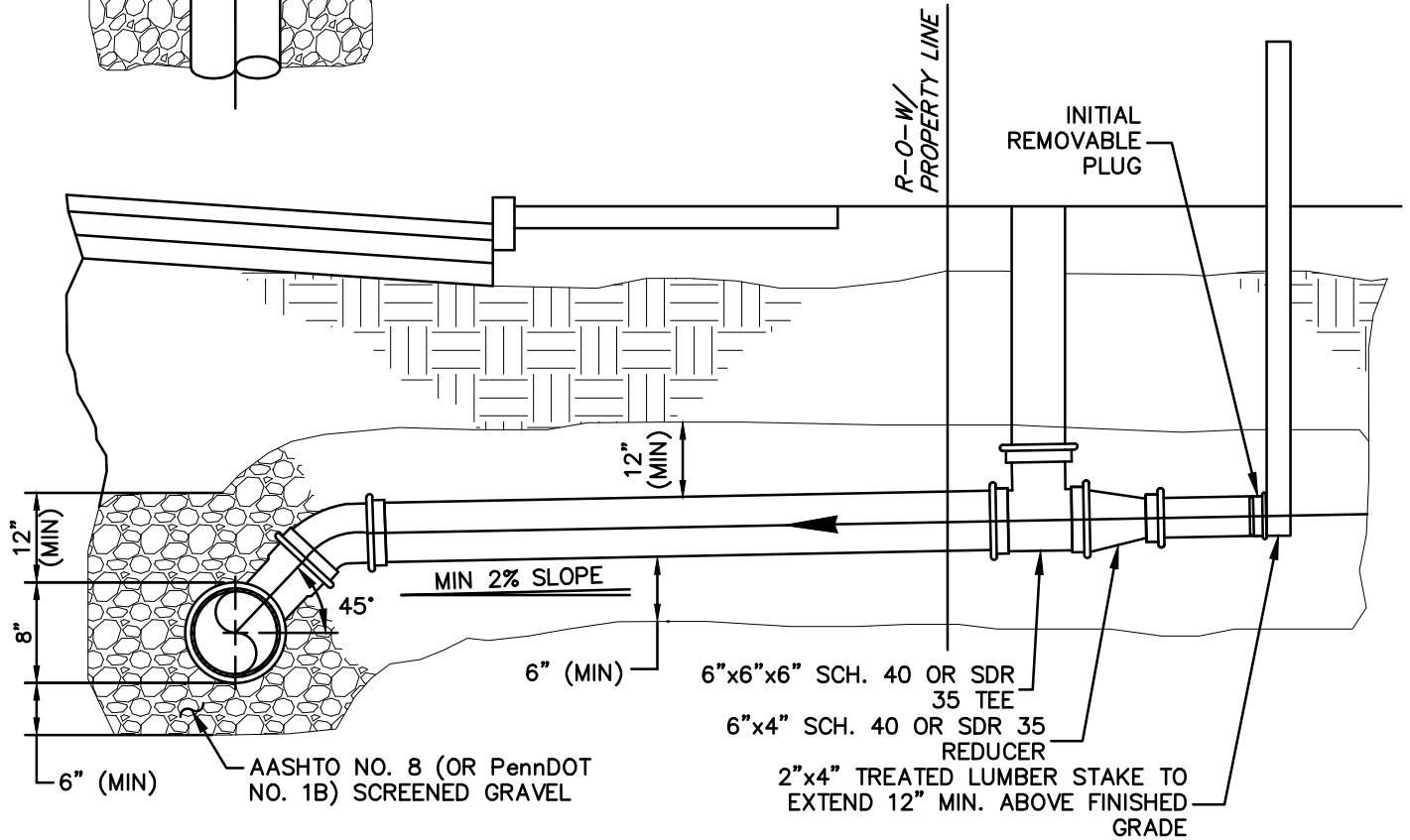
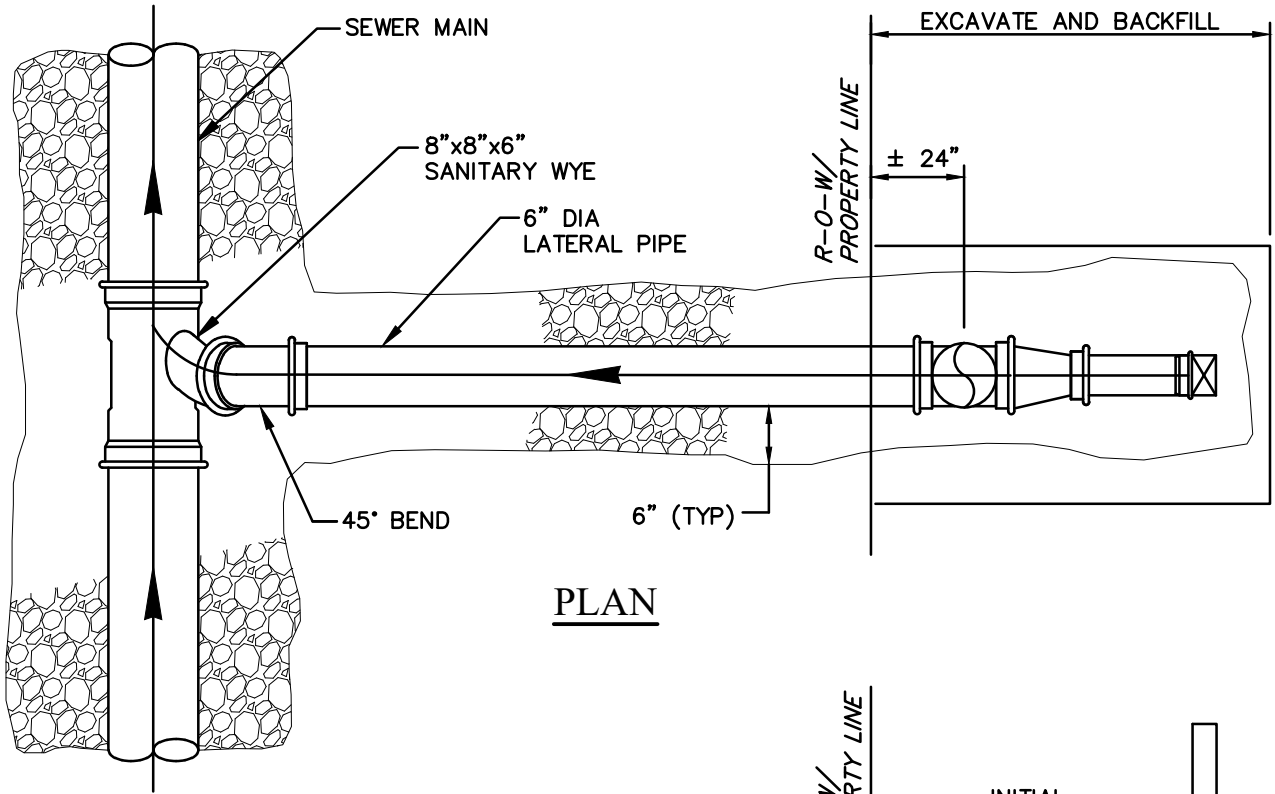

SHALLOW SANITARY LATERAL

NO SCALE

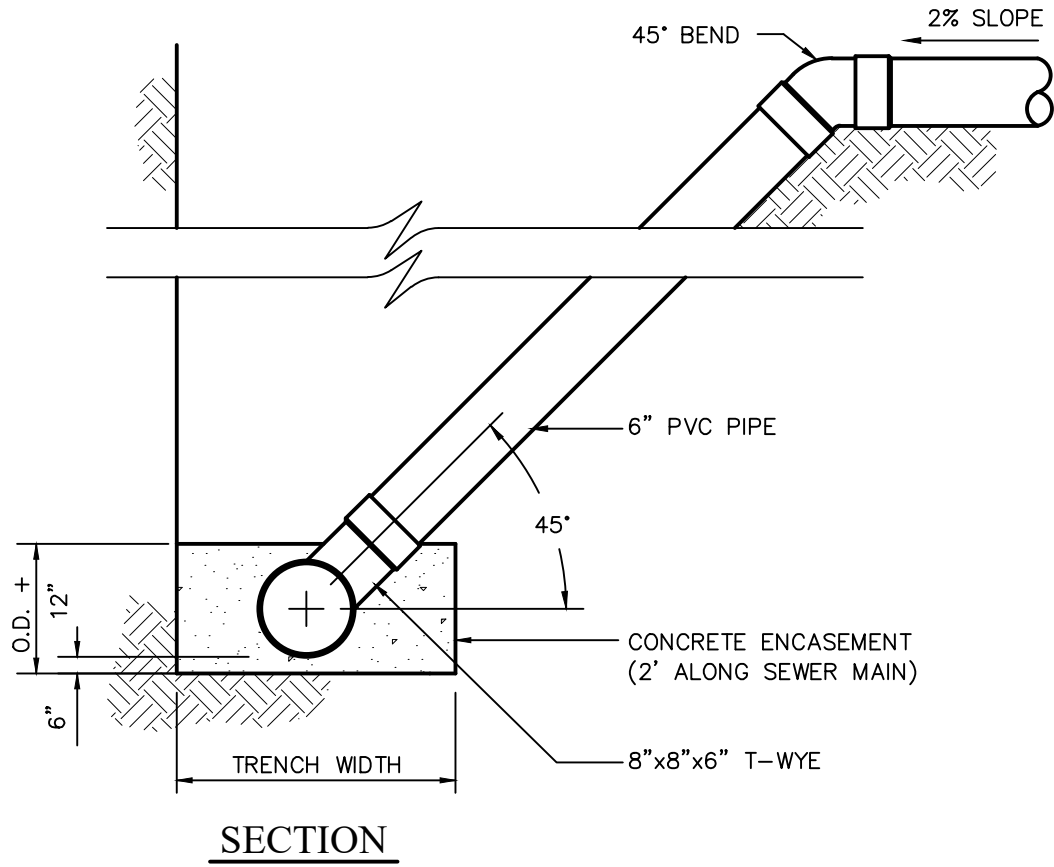

DEEP SANITARY SEWER LATERAL (12' AND DEEPER)

NOT TO SCALE

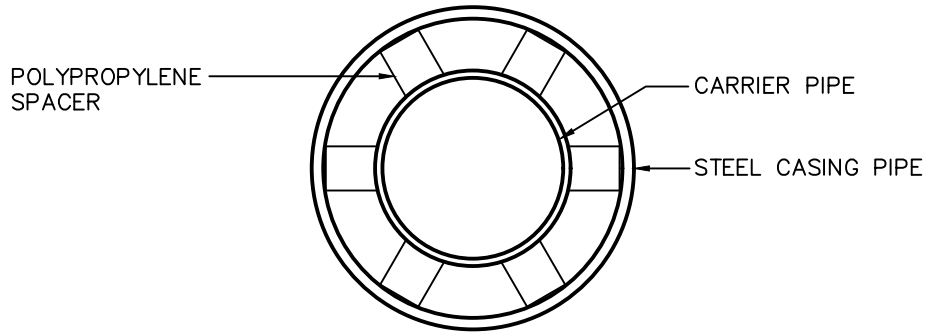

SECTION

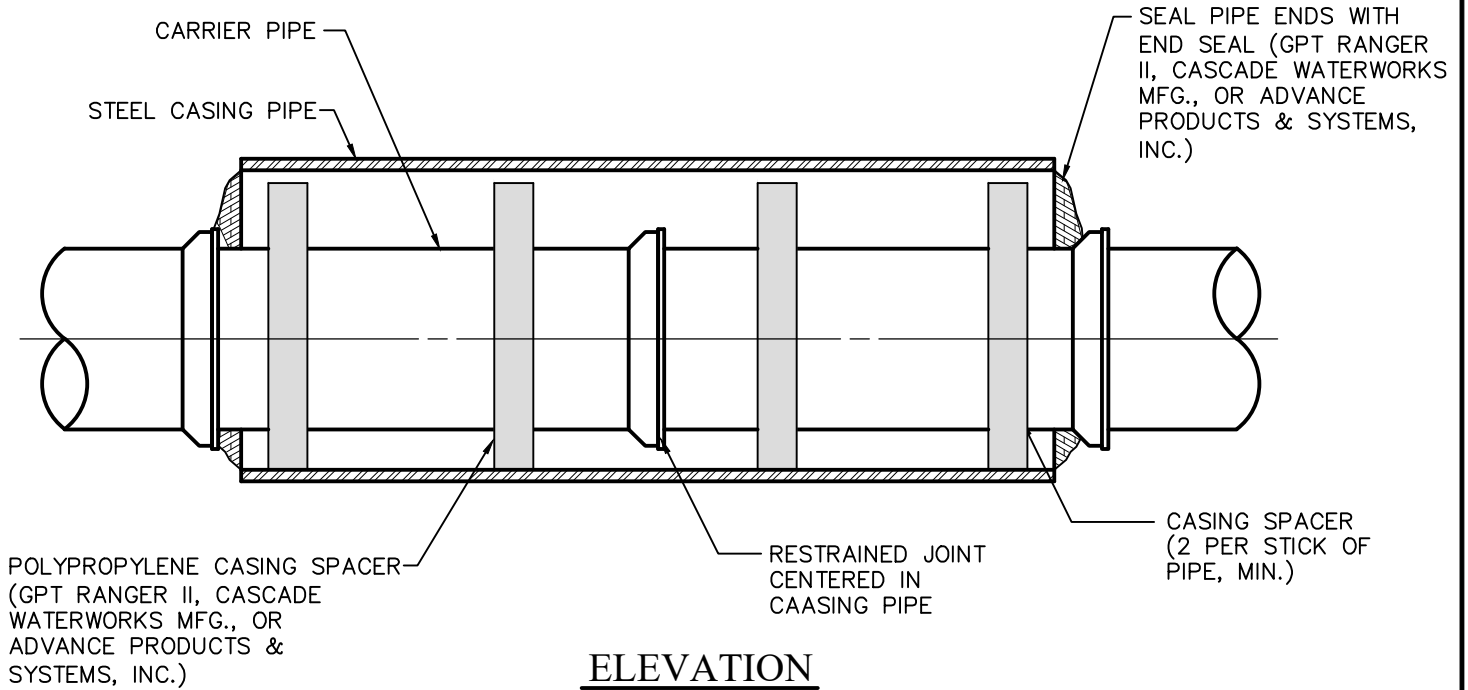

ELEVATION

PIPE CASING

NOT TO SCALE

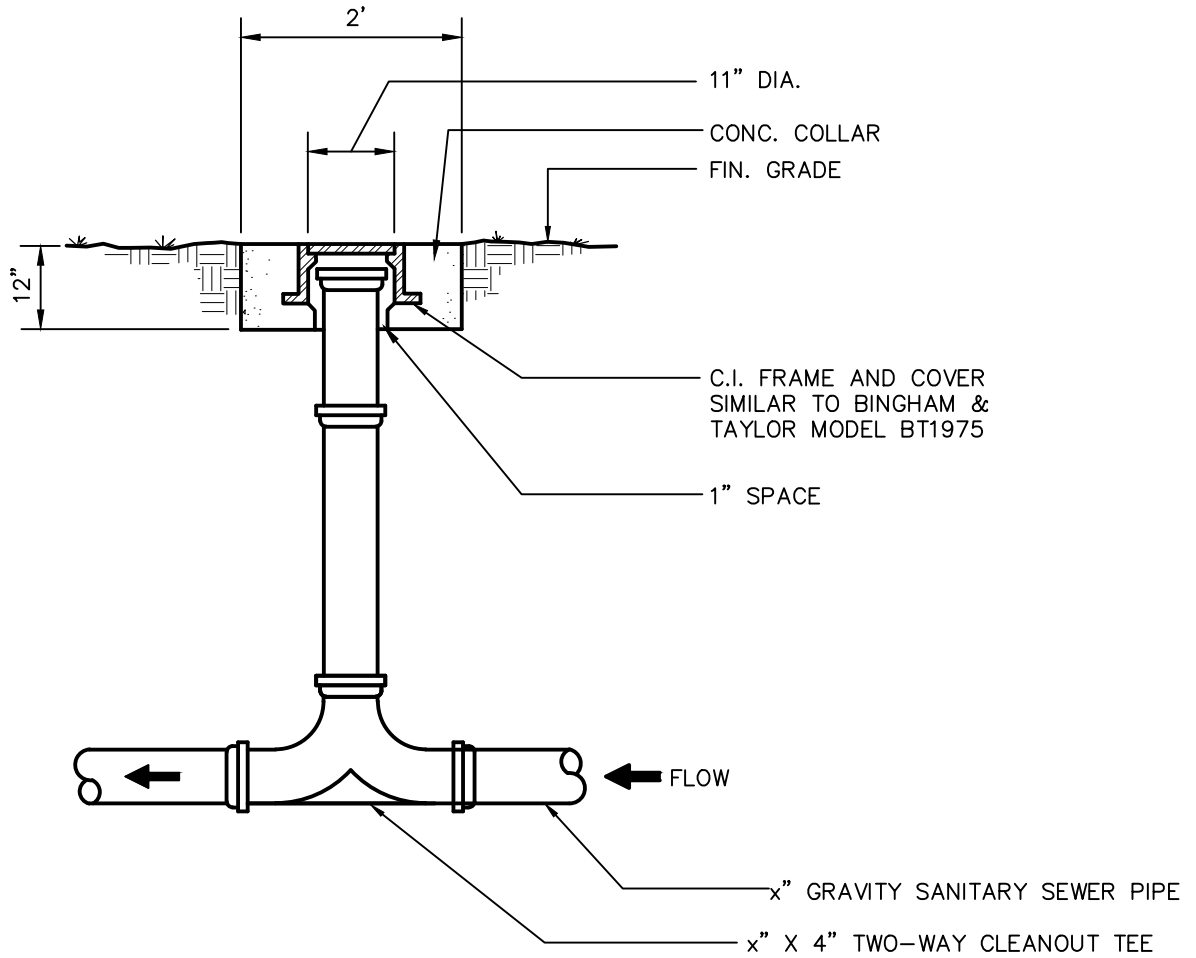

CLEANOUT

NOT TO SCALE

NOTE:
ELEVATIONS AND DIMENSIONS (*) MUST BE INSERTED ON THIS DETAIL PRIOR TO AUTHORITY APPROVAL..

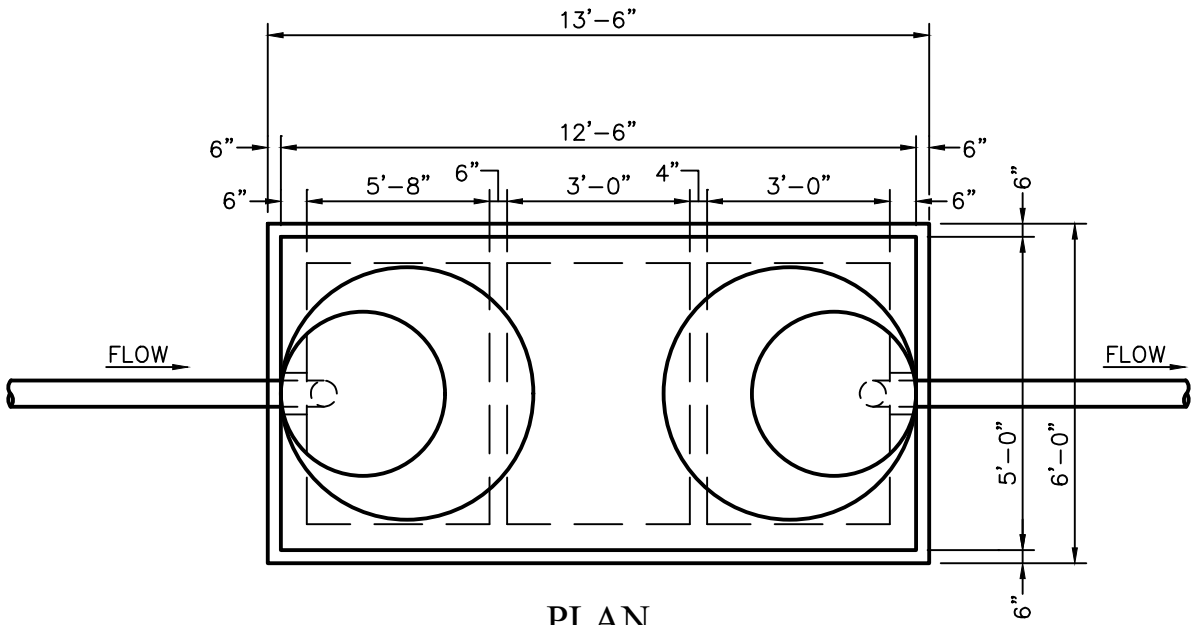

PLAN

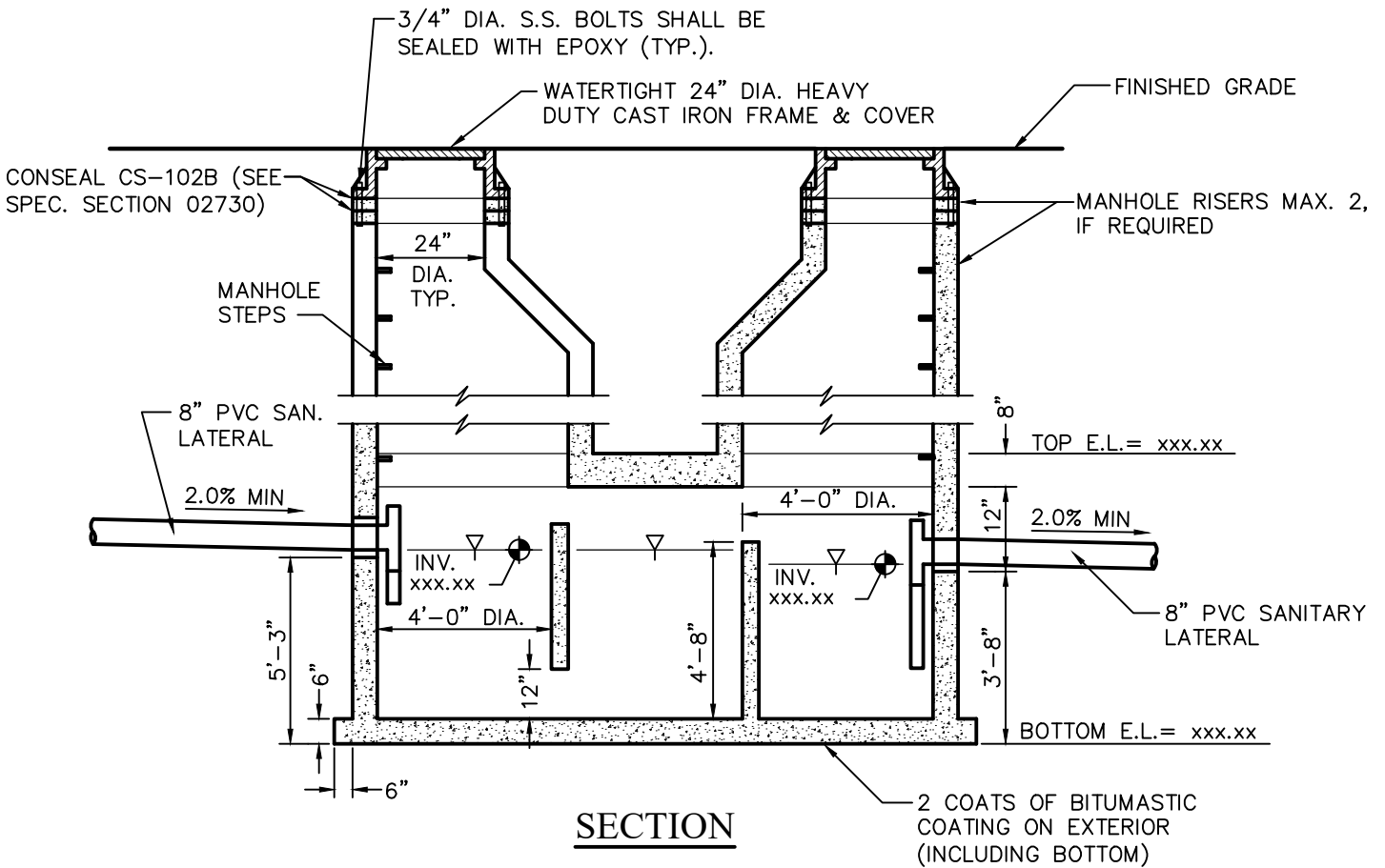

SECTION

2000 GALLON GREASE INTERCEPTOR

NOT TO SCALE

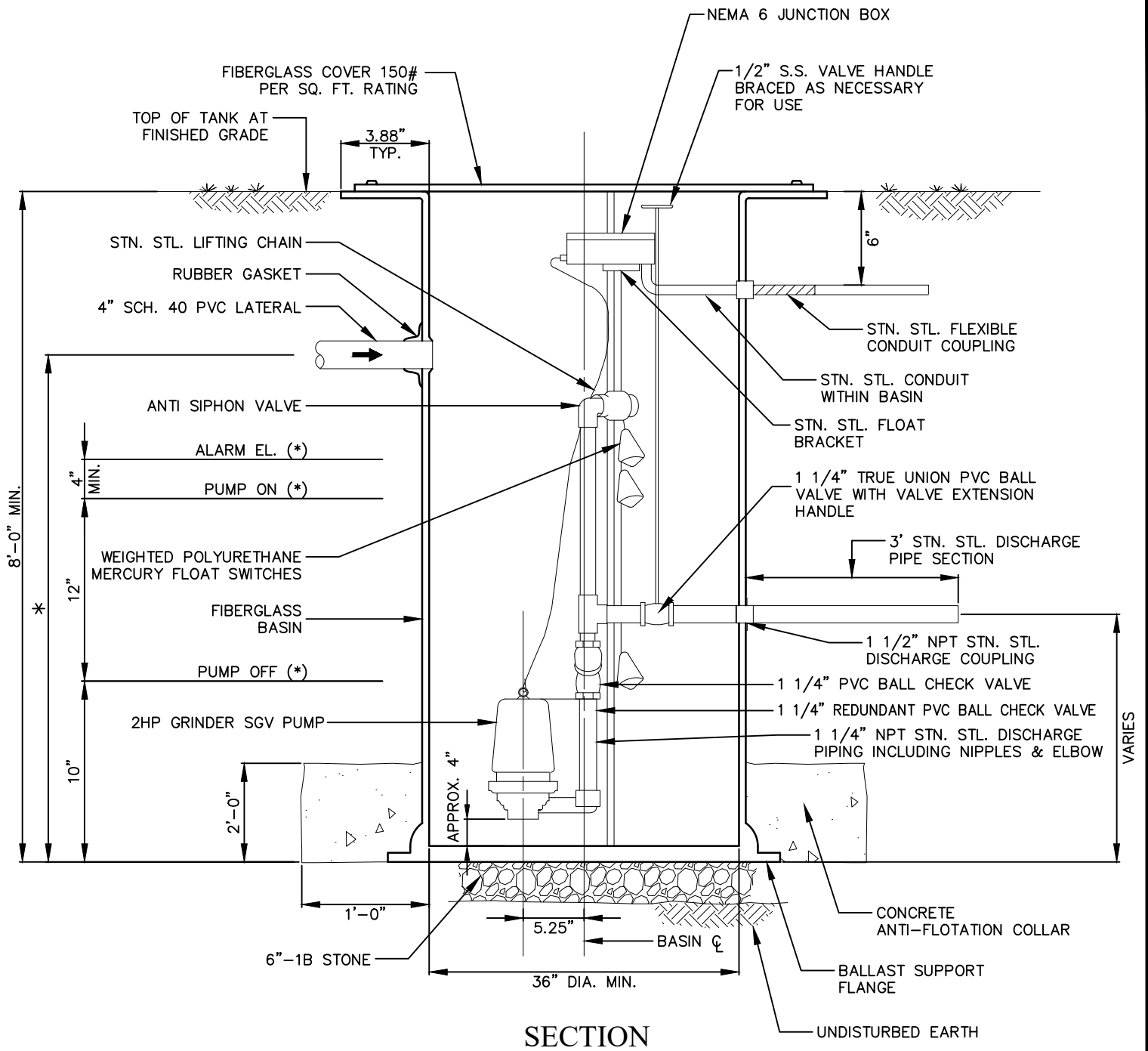

SECTION

NOTE:
 ELEVATIONS AND DIMENSIONS (*)
 MUST BE INSERTED ON THIS DETAIL
 PRIOR TO AUTHORITY APPROVAL.
 CONTRACTOR TO PROVIDE
 CALCULATIONS WITH SUBMITTALS.

**SIMPLEX GRINDER PUMP STATION
 FIBERGLASS BASIN - SECTION**

NO SCALE

NOTES:

1. CONTRACTOR SHALL PROVIDE A MINIMUM 3' SECTION OF 1 1/2" STAINLESS STEEL DISCHARGE PIPING OUTSIDE OF BASIN. THE 1 1/2" STAINLESS STEEL PIPE SHALL BE CONNECTED TO THE 1 1/2" PVC SERVICE LATERAL BY USE OF A COMPRESSION FITTING OR DRESSER COUPLING.
2. BACKFILL WITH EXCAVATED MATERIAL APPROVED BY THE ENGINEER & CONTAINING NO SOIL LUMPS, STONE, CONCRETE OR FOREIGN OBJECTS LARGER THAN ONE (1) INCH IN MAXIMUM DIMENSION OR WITH CLASS 1S MATERIAL CONSISTING OF NO. 8 COARSE AGGREGATE TO 6" BELOW GRADE; THEN TOPSOIL & SEED TOP 6".
3. MINIMUM NET EFFECTIVE STORAGE VOLUME BETWEEN PUMP SHUT-OFF ELEVATION & INVERT OF INFLUENT LINE SHALL BE 150 GALLONS.
4. ALL COVER & ACCESS HARDWARE SHALL BE STAINLESS STEEL INCLUDING ALL NUTS, BOLTS, WASHERS, ETC. WHICH PENETRATE THE COVER OR THE BASIN.
5. ALL CONTROL PANEL EXTERIOR HARDWARE SHALL BE STAINLESS STEEL.
6. CONCRETE BASINS SHALL BE USED IN AREAS SUBJECT TO TRAFFIC LOADING; SUCH AS DRIVEWAYS AND PARKING LOTS..
7. LOCATION OF BASIN TO BE DETERMINED BY PROPERTY OWNER.
8. FINISHED GRADE SHALL BE SLOPED AWAY FROM THE BASIN TOP.
9. ALL GRINDER PUMPS STATIONS SHALL HAVE ANTI-SIPHON FEATURE INCORPORATED. THE AUTHORITY SHALL REVIEW AND APPROVE ALL PROPOSED ANTI-SIPHONING EQUIPMENT.
10. INSTALL TRACER WIRE ON ALL LOW PRESSURE SEWER SERVICE LINES, AS SPECIFIED IN SECTION 013-2733.

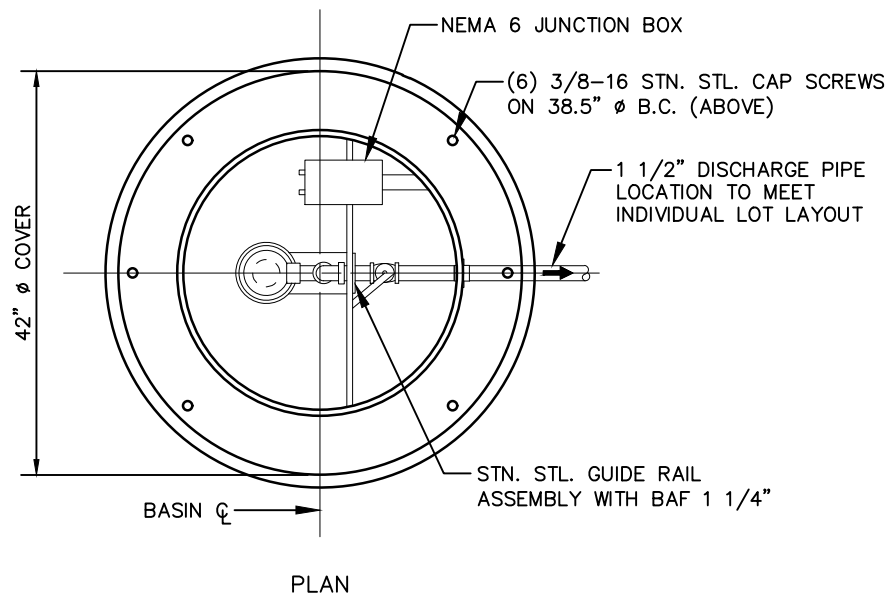

SIMPLEX GRINDER PUMP STATION FIBERGLASS BASIN - PLAN

NO SCALE

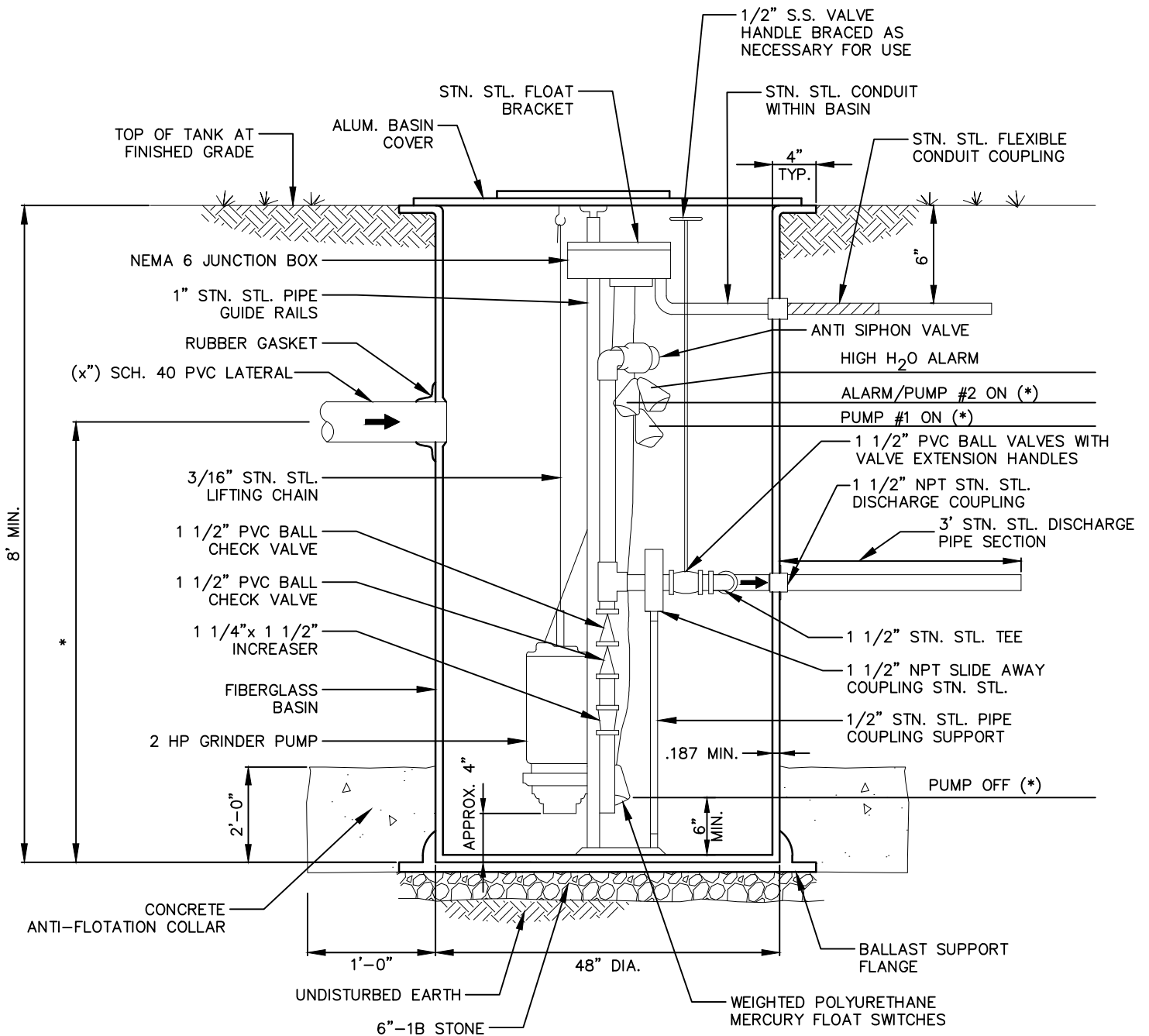

SECTION

NOTE:
 ELEVATIONS AND DIMENSIONS (*) MUST BE INSERTED ON THIS DETAIL PRIOR TO AUTHORITY APPROVAL
 PROVIDE ADDITIONAL BRACING FOR BASINS 144" AND DEEPER.

**DUPLEX GRINDER PUMP STATION
 FIBERGLASS BASIN - SECTION**

NO SCALE

NOTES:

1. CONTRACTOR SHALL PROVIDE A MINIMUM 3' SECTION OF 1 1/2" STAINLESS STEEL DISCHARGE PIPING OUTSIDE OF BASIN. THE 1 1/2" STAINLESS STEEL PIPE SHALL BE CONNECTED TO THE 1 1/2" PVC SERVICE LATERAL BY USE OF A COMPRESSION FITTING OR DRESSER COUPLING.
2. BACKFILL WITH EXCAVATED MATERIAL APPROVED BY THE ENGINEER & CONTAINING NO SOIL LUMPS, STONE, CONCRETE OR FOREIGN OBJECTS LARGER THAN ONE (1) INCH IN MAXIMUM DIMENSION OR WITH CLASS 1S MATERIAL CONSISTING OF NO. 8 COARSE AGGREGATE TO 6" BELOW GRADE; THEN TOPSOIL & SEED TOP 6".
3. MINIMUM NET EFFECTIVE STORAGE VOLUME BETWEEN PUMP SHUT-OFF ELEVATION & INVERT OF INFLUENT LINE SHALL BE 150 GALLONS.
4. ALL COVER & ACCESS HARDWARE SHALL BE STAINLESS STEEL INCLUDING ALL NUTS, BOLTS, WASHERS, ETC. WHICH PENETRATE THE COVER OR THE BASIN.
5. ALL CONTROL PANEL EXTERIOR HARDWARE SHALL BE STAINLESS STEEL.
6. CONCRETE BASINS SHALL BE USED IN AREAS SUBJECT TO TRAFFIC LOADING; SUCH AS DRIVEWAYS AND PARKING LOTS..
7. LOCATION OF BASIN TO BE DETERMINED BY PROPERTY OWNER.
8. FINISHED GRADE SHALL BE SLOPED AWAY FROM THE BASIN TOP.
9. ALL GRINDER PUMPS STATIONS SHALL HAVE ANTI-SIPHON FEATURE INCORPORATED. THE AUTHORITY SHALL REVIEW AND APPROVE ALL PROPOSED ANTI-SIPHONING EQUIPMENT.
10. INSTALL TRACER WIRE ON ALL LOW PRESSURE SEWER SERVICE LINES, AS SPECIFIED IN SECTION 013-2733.

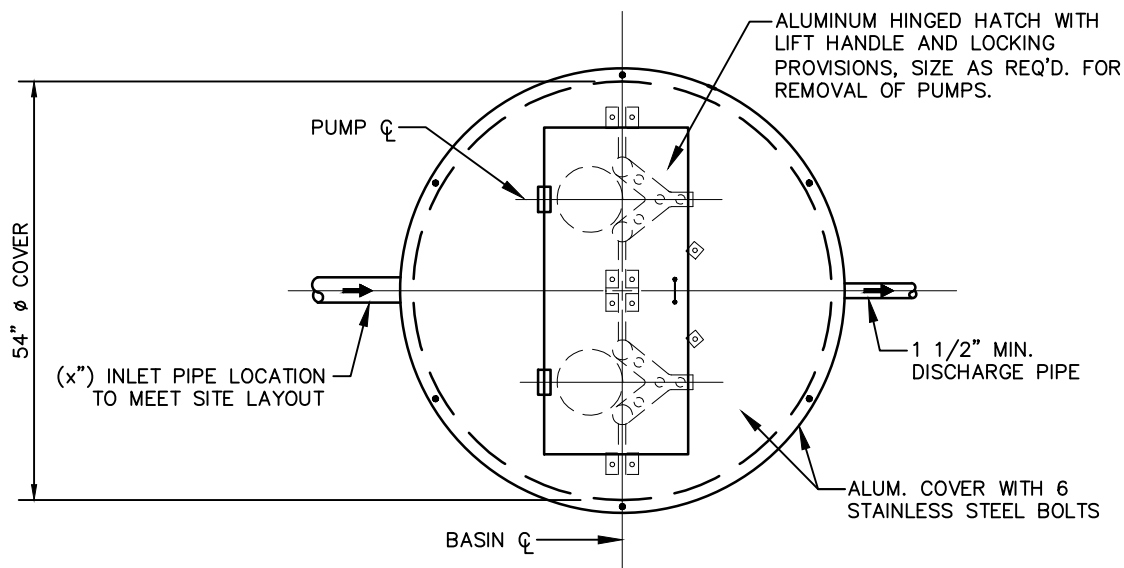

PLAN

DUPLEX GRINDER PUMP STATION FIBERGLASS BASIN - PLAN

NO SCALE

NOTES:

1. CONTRACTOR SHALL PROVIDE A MINIMUM 3' SECTION OF 1 1/2" STAINLESS STEEL DISCHARGE PIPING OUTSIDE OF BASIN. THE 1 1/2" STAINLESS STEEL PIPE SHALL BE CONNECTED TO THE 1 1/2" PVC SERVICE LATERAL BY USE OF A COMPRESSION FITTING OR DRESSER COUPLING.
2. BACKFILL WITH EXCAVATED MATERIAL APPROVED BY THE ENGINEER & CONTAINING NO SOIL LUMPS, STONE, CONCRETE OR FOREIGN OBJECTS LARGER THAN ONE (1) INCH IN MAXIMUM DIMENSION OR WITH CLASS 1S MATERIAL CONSISTING OF NO. 8 COARSE AGGREGATE TO 6" BELOW GRADE; THEN TOPSOIL & SEED TOP 6".
3. MINIMUM NET EFFECTIVE STORAGE VOLUME BETWEEN PUMP SHUT-OFF ELEVATION & INVERT OF INFLUENT LINE SHALL BE 250 GALLONS OR 24 HOURS OF STORAGE VOLUME, WHICHEVER IS GREATER.
4. ALL COVER & ACCESS HARDWARE SHALL BE STAINLESS STEEL INCLUDING ALL NUTS, BOLTS, WASHERS, ETC. WHICH PENETRATE THE COVER OR THE BASIN.
5. ALL CONTROL PANEL EXTERIOR HARDWARE SHALL BE STAINLESS STEEL.
6. FIBERGLASS BASINS MAY NOT BE USED IN AREAS SUBJECT TO TRAFFIC LOADING.
7. LOCATION OF BASIN TO BE DETERMINED BY PROPERTY OWNER.
8. FINISHED GRADE SHALL BE SLOPED AWAY FROM THE BASIN TOP.
9. INTERIOR OF MANHOLE SHALL HAVE PROTECTIVE PVC COATING IN ACCORDANCE WITH SPECIFICATIONS.
10. EXTERIOR SHALL HAVE 2 COATS BITUMASTIC COATING (INCLUDING BOTTOM)
11. ALL GRINDER PUMPS STATIONS SHALL HAVE ANTI-SIPHON FEATURE INCORPORATED. THE AUTHORITY SHALL REVIEW AND APPROVE ALL PROPOSED ANTI-SIPHONING EQUIPMENT.
12. INSTALL TRACER WIRE ON ALL LOW PRESSURE SEWER SERVICE LINES, AS SPECIFIED IN SECTION 013-2733.

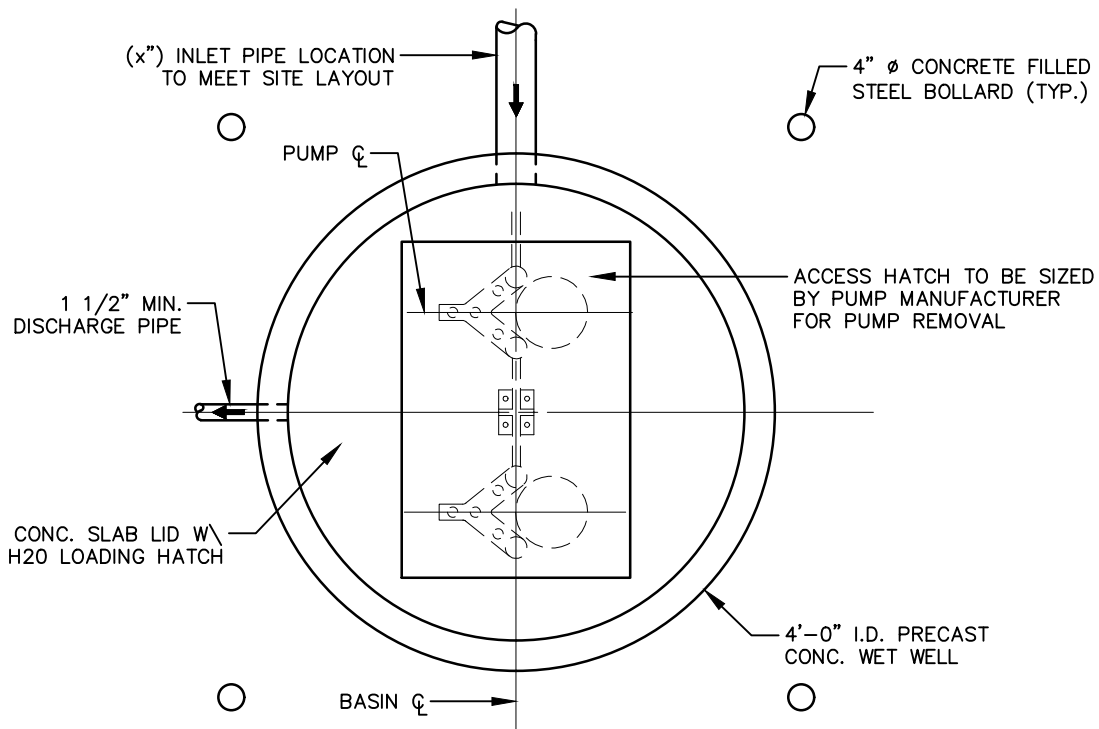
PLAN

DUPLEX GRINDER PUMP STATION CONCRETE BASIN - PLAN

NO SCALE

THIS PAGE INTENTIONALLY LEFT BLANK

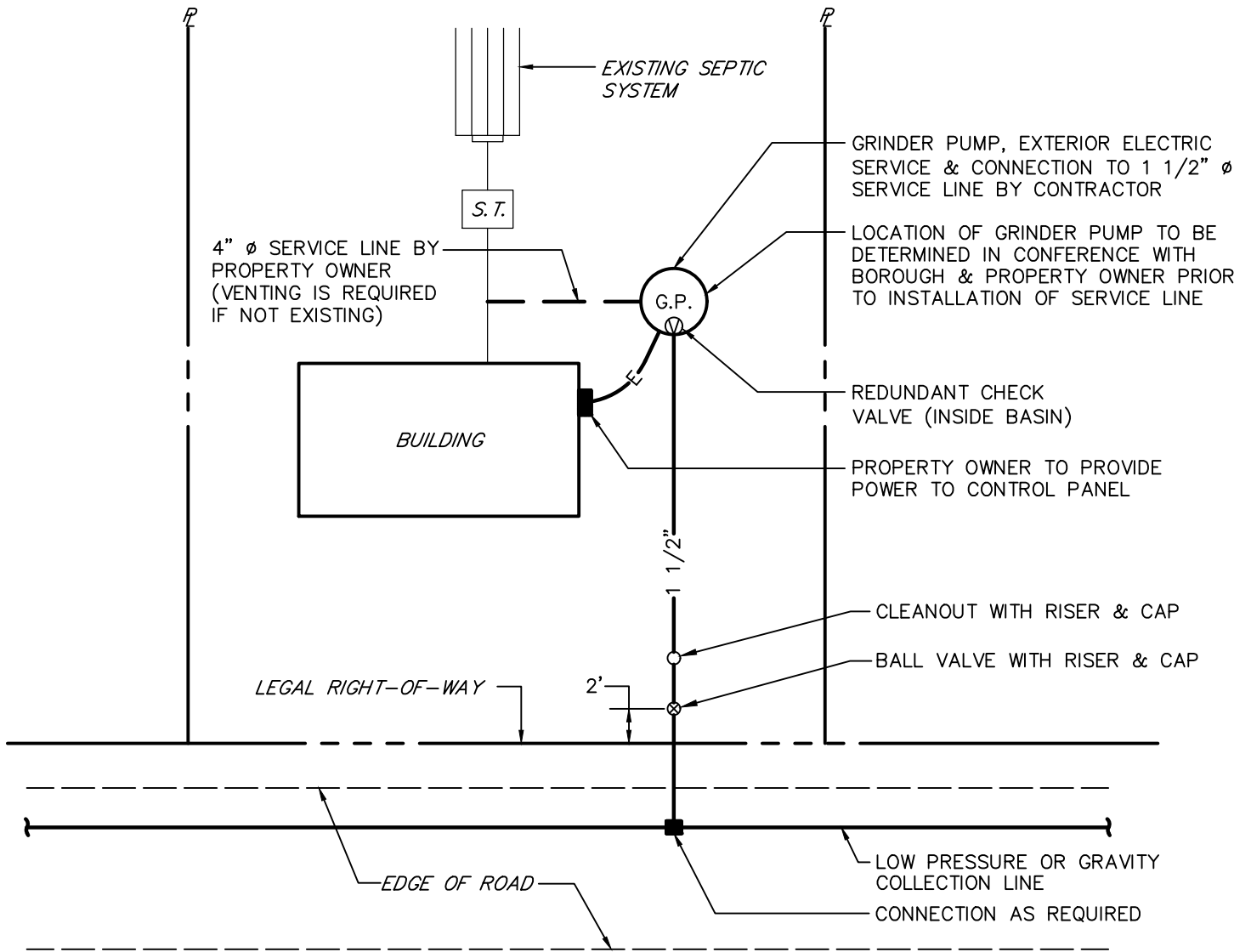

TYPICAL LOW PRESSURE SEWER PROPERTY CONNECTION SCHEMATIC

NOT TO SCALE

TYPICAL BASIN TOP AREA SHADED ALONG CIRCUMFERENCE OF THE BASIN SHOULD NOT BE USED FOR HOUSE CONNECTION. THIS IS THE AREA IN WHICH THE ELECTRIC CABLES AND FLOATS ARE LOCATED. ANY OTHER AREA ON BASIN IS ACCEPTABLE. PLUMBER MAKING CONNECTION MUST OPEN HATCH TO CONFIRM LOCATION OF ELECTRICAL CONTROLS.

FOR 1.5" PIPE
OUTLET/DISCHARGE

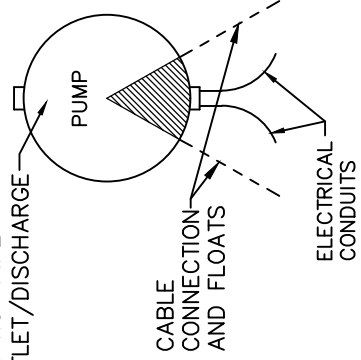

2" STAINLESS STEEL PIPE WITH 2" STAINLESS STEEL CAP.

RAINTIGHT LOCKABLE CONTROL ENCLOSURE WITH MAIN CIRCUIT BREAKER CONTROLS MOUNTED TO PIPE WITH 2" STAINLESS STEEL U-BOLTS.

3/4" DIA PVC SCHEDULE 40 CONDUIT PROPERLY SUPPORTED FOR INCOMING POWER WIRING & WIRING TO GRINDER PUMP BASIN.

CONDUIT COUPLINGS.

6" ABOVE FINISHED GRADE.

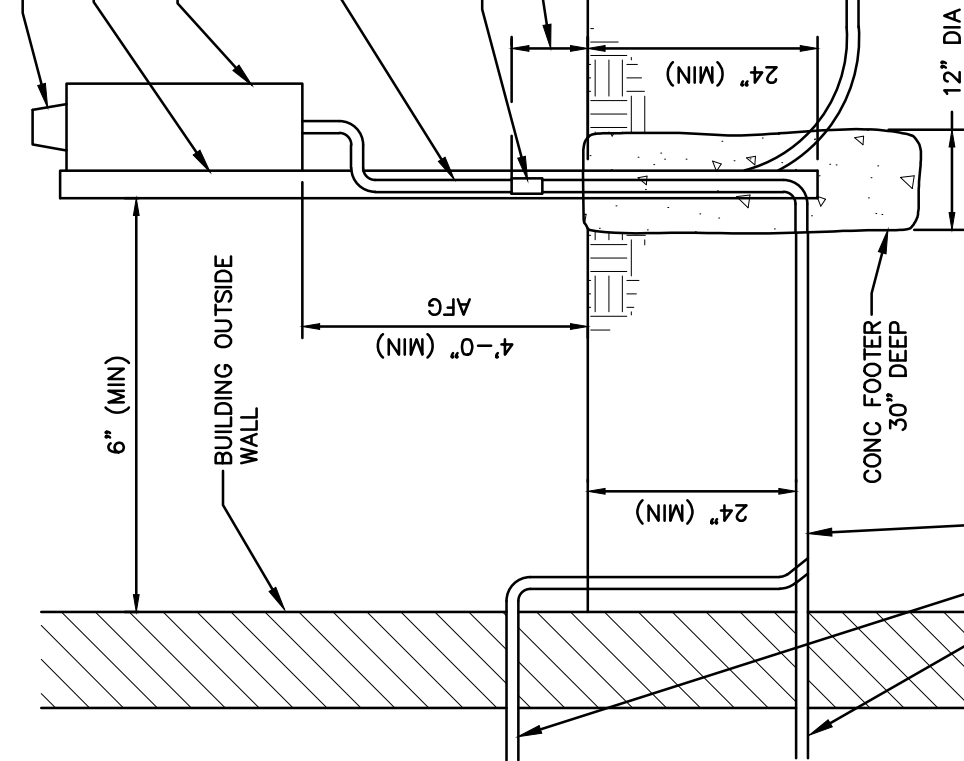

ELECTRICAL SERVICE & WIRING BY PROPERTY OWNER. CONTRACTOR RESPONSIBLE FOR ELECTRICAL WIRING & CONDUIT WITHIN 24" OF FINAL CONTROL PANEL LOCATION.

CONDUIT AND WIRE SIZING TO DEPEND ON POWER REQUIREMENTS OF THE CONTROL PANEL AND THE DISTANCE BETWEEN THE PANEL AND SERVICE ENTRANCE. THE MOST CURRENT VERSION OF NEC AND IBC CODES MUST BE FOLLOWED AND TAKE PRECEDENCE.

NOTE:

1. INSTALL TRACER WIRE ON ALL LOW PRESSURE SERVICE LINES, AS SPECIFIED IN SECTION 02733.

INSTALL S.S. FLEXIBLE CONDUIT AND COUPLING. THIS CONNECTION TO BE MADE WITH RUBBER SEALING RING, PROVIDED WITH FIBERGLASS TANK.

GRINDER PUMP POST MOUNTED CONTROL PANEL

NO SCALE

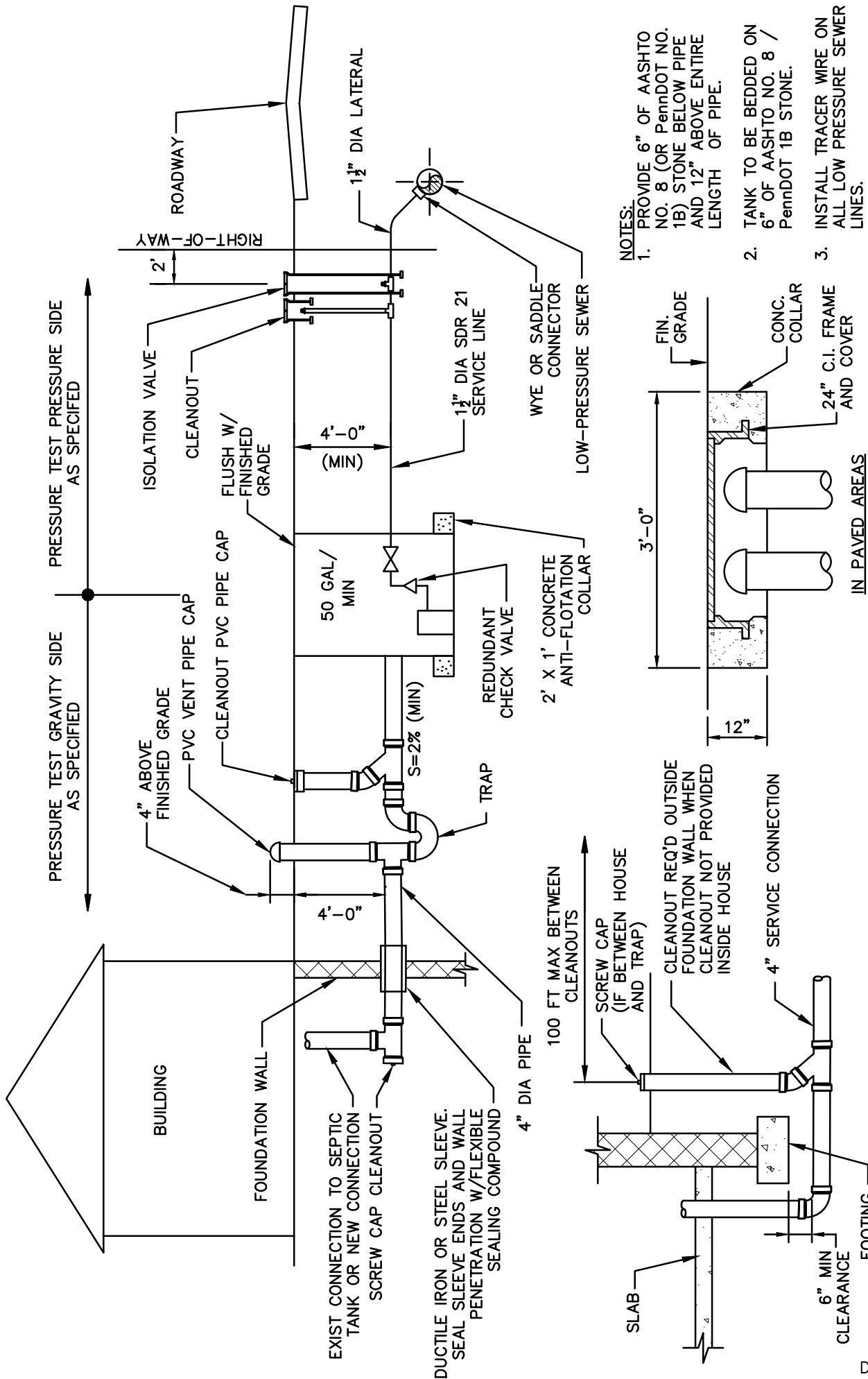

- NOTES:**
1. PROVIDE 6" OF AASHTO NO. 8 (OR PennDOT NO. 1B) STONE BELOW PIPE AND 12" ABOVE ENTIRE LENGTH OF PIPE.
 2. TANK TO BE BEDDED ON 6" OF AASHTO NO. 8 / PennDOT 1B STONE.
 3. INSTALL TRACER WIRE ON ALL LOW PRESSURE SEWER LINES.

TYPICAL GRINDER PUMP SERVICE LINE TO LOW PRESSURE SEWER SCHEMATIC

NO SCALE

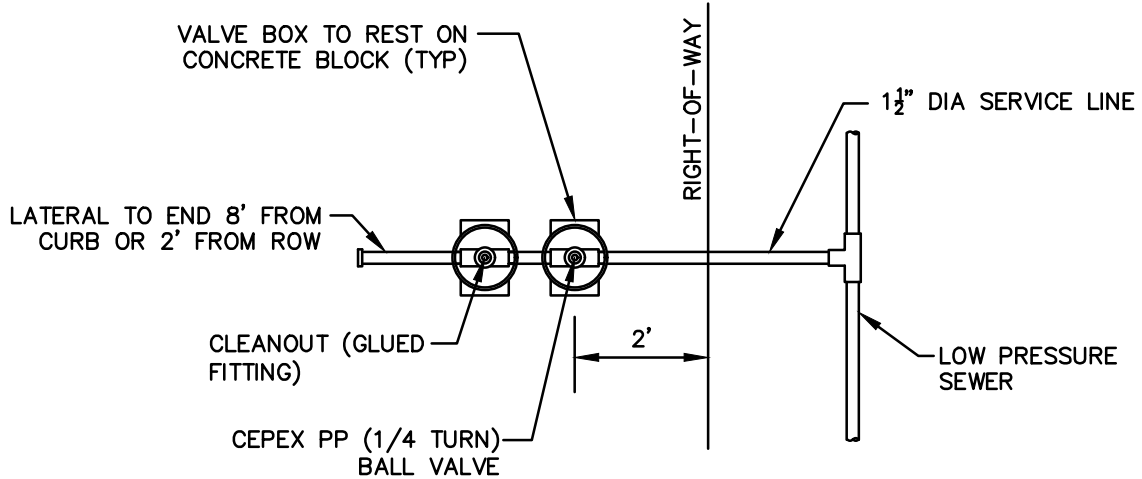

PLAN

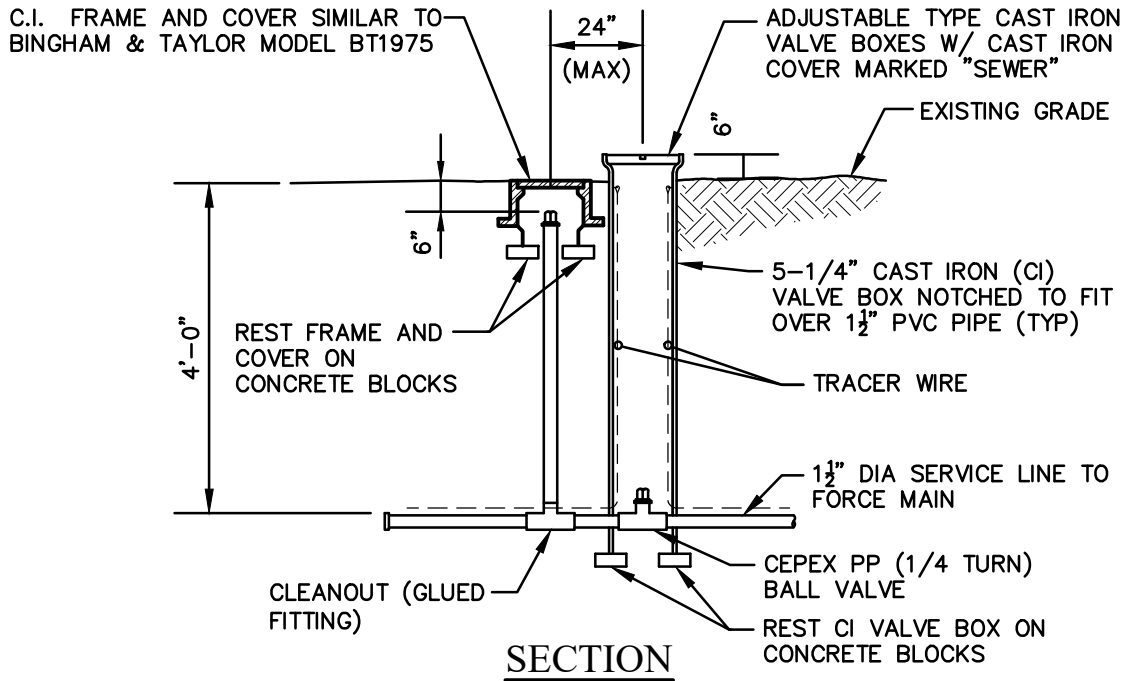

SECTION

NOTES:

1. ALL PVC CONNECTIONS SHALL BE SOLVENT WELDED UNLESS NOTED OTHERWISE.
2. PROVIDE 6" OF AASHTO NO. 8 (OR PennDOT NO. 1B) STONE BELOW PIPE AND 12" ABOVE ENTIRE LENGTH OF PIPE.
3. TRACER WIRE TO LOOP IN VALVE BOX.
4. CLEANOUT CAP SHALL BE A FEMALE THREAD STAINLESS STEEL CAP.

**TYPICAL LATERAL CONNECTION TO
LOW PRESSURE FORCEMAIN**

NO SCALE

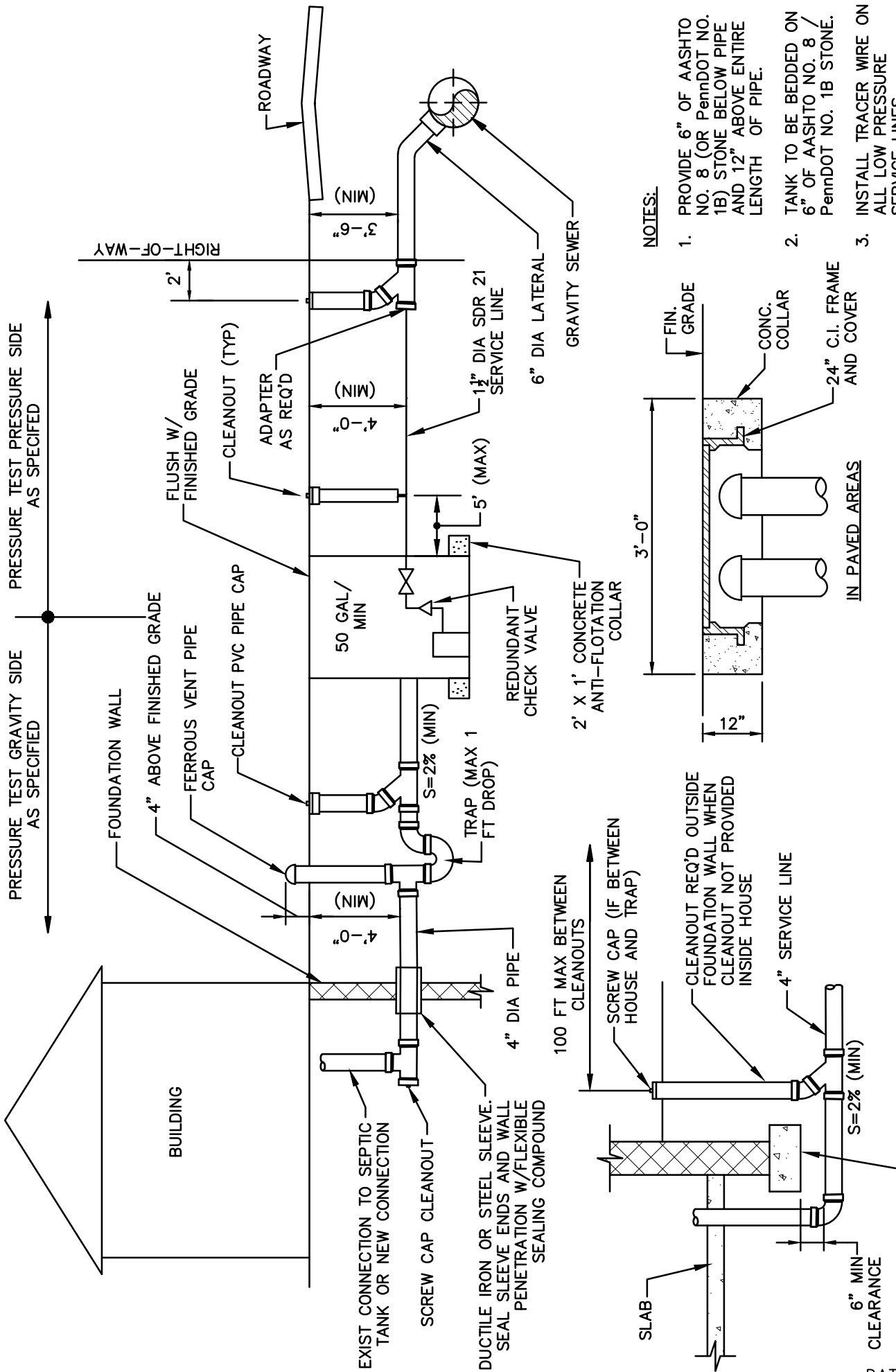

NOTES:

1. PROVIDE 6" OF AASHTO NO. 8 (OR PennDOT NO. 1B) STONE BELOW PIPE AND 12" ABOVE ENTIRE LENGTH OF PIPE.
2. TANK TO BE BEDDED ON 6" OF AASHTO NO. 8 / PennDOT NO. 1B STONE.
3. INSTALL TRACER WIRE ON ALL LOW PRESSURE SERVICE LINES.

TYPICAL GRINDER PUMP SERVICE LINE TO GRAVITY SEWER SCHEMATIC

NO SCALE

THIS PAGE INTENTIONALLY LEFT BLANK

THIS PAGE INTENTIONALLY LEFT BLANK

NOTES:

1. CLAY DIKE SHALL CONSIST OF CLAY CONTAINING NO MORE THAN 15% (BY VOLUME) STONE NO LARGER THAN TWO (2) INCHES IN DIAMETER. CLAY SHALL BE PLACED IN SIX (6) INCH LIFTS AND COMPACTED BY A MECHANICAL TAMPER TO NOT LESS THAN 95% OF MAXIMUM DENSITY AT OPTIMUM MOISTURE CONTENT.
2. INSTALL CLAY DIKES EVERY 200'. A MINIMUM OF ONE CLAY DIKE SHALL BE INSTALLED PER SANITARY SEWER MANHOLE RUN.

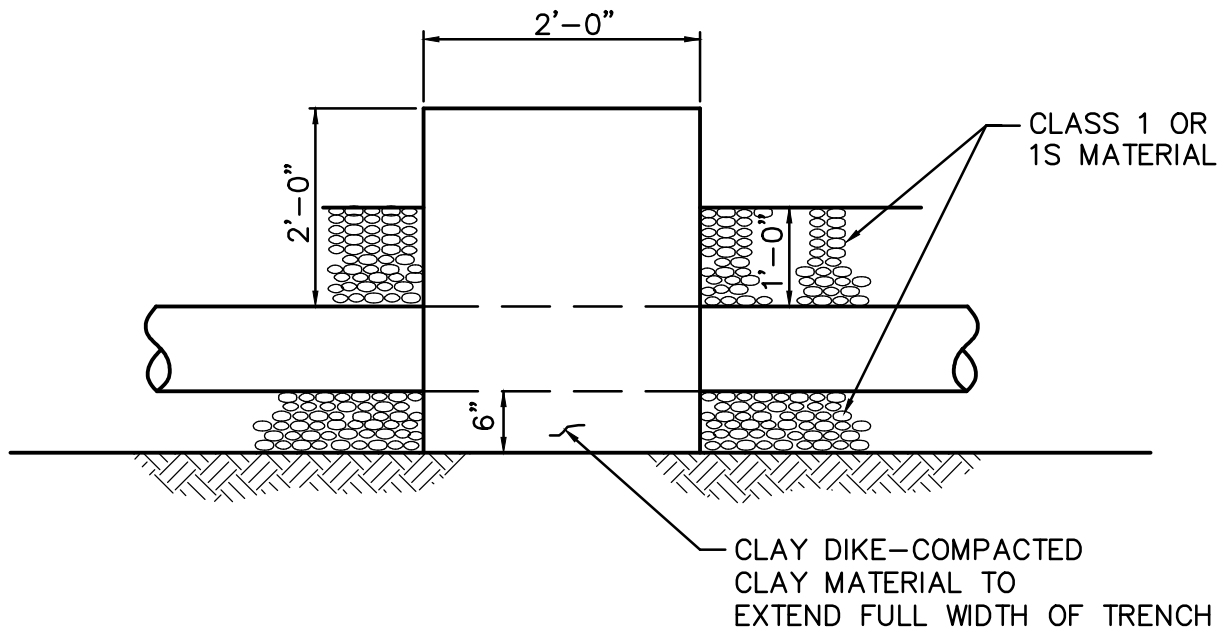

CLAY DIKE DETAIL

NOT TO SCALE

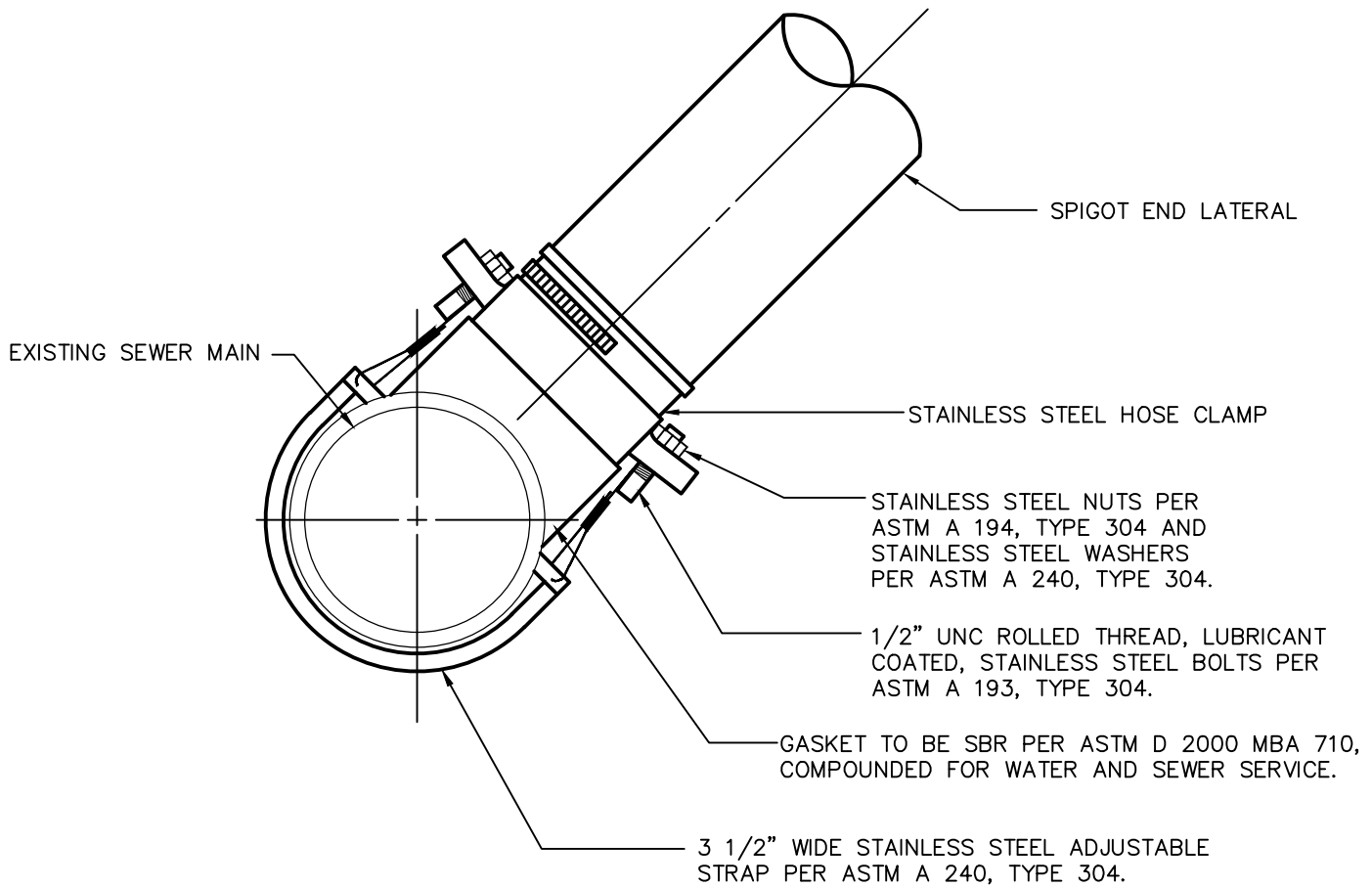

- NOTES:
1. FOR USE ONLY WITH AUTHORITY'S SPECIFIC APPROVAL.
 2. SADDLE SHALL BE ENCASED IN CONCRETE.
 3. PIPE SADDLES SHALL BE STYLE "CB" SEWER SADDLE AS MANUFACTURED BY ROMAC INDUSTRIES, INC. OR APPROVED EQUAL.
 4. INSTALLATION SHALL BE IN ACCORDANCE WITH MANUFACTURER'S INSTRUCTIONS.
 5. THE CONTRACTOR SHALL MAKE THE TAP INTO THE EXISTING PIPE USING SUITABLE HOLE CUTTING EQUIPMENT AND WITHOUT DAMAGING THE EXISTING PIPE.

SADDLE CONNECTION

NOT TO SCALE

NOTES:

1. THRUST BLOCKING FOR TEES SHALL HAVE THE SAME BEARING AREA AS 90° BENDS OF THE PIPE SIZE OF THE OUTLET. DEAD ENDS SHALL HAVE THE SAME BEARING AS 90° BENDS.
2. NO COUPLING OR JOINTS SHALL BE COVERED WITH CONCRETE.
3. REINFORCING BAR STRAPS TO BE SHAPED TO PIPE CURVATURE.
4. ALL EXPOSED STEEL TO BE PAINTED WITH TWO COATS ASPHALTIC PAINT.

BEARING AREA REQUIRED, SQUARE FEET

TYPE OF BEARING MATERIAL AND ALLOWABLE LOADS, PSF	4" AND LESS DEGREE BEND				6" AND 8" DEGREE BEND				10" AND 12" DEGREE BEND			
	11 1/4'	22 1/2'	45'	90'	11 1/4'	22 1/2'	45'	90'	11 1/4'	22 1/2'	45'	90'
LOOSE SAND OR MEDIUM CLAY - 2,000	1.0	2.0	2.7	4.0	1.5	3.0	6.0	10.0	3.0	6.2	12.0	22.0
PACKED GRAVEL AND SAND - 4,000	1.0	1.0	1.5	2.0	1.0	1.5	3.0	5.0	1.5	3.1	6.0	11.0
ROCK - 10,000	1.0	1.0	1.0	1.0	1.0	1.0	1.2	2.0	1.0	1.3	2.4	4.4

BEARING AREA REQUIRED, SQUARE FEET

TYPE OF BEARING MATERIAL AND ALLOWABLE LOADS, PSF	14" AND 16" DEGREE BEND OR DEFLECTION				18" AND 20" DEGREE BEND OR DEFLECTION			
	11 1/4'	22 1/2'	45'	90'	11 1/4'	22 1/2'	45'	90'
LOOSE SAND OR MEDIUM CLAY - 2,000	6.0	12.0	22.5	40.0	9.5	19.0	37.0	67.0
PACKED GRAVEL AND SAND - 4,000	3.0	6.0	11.3	20.0	4.8	9.5	18.5	33.5
ROCK - 10,000	1.2	2.4	4.5	8.0	2.0	3.8	7.4	13.5

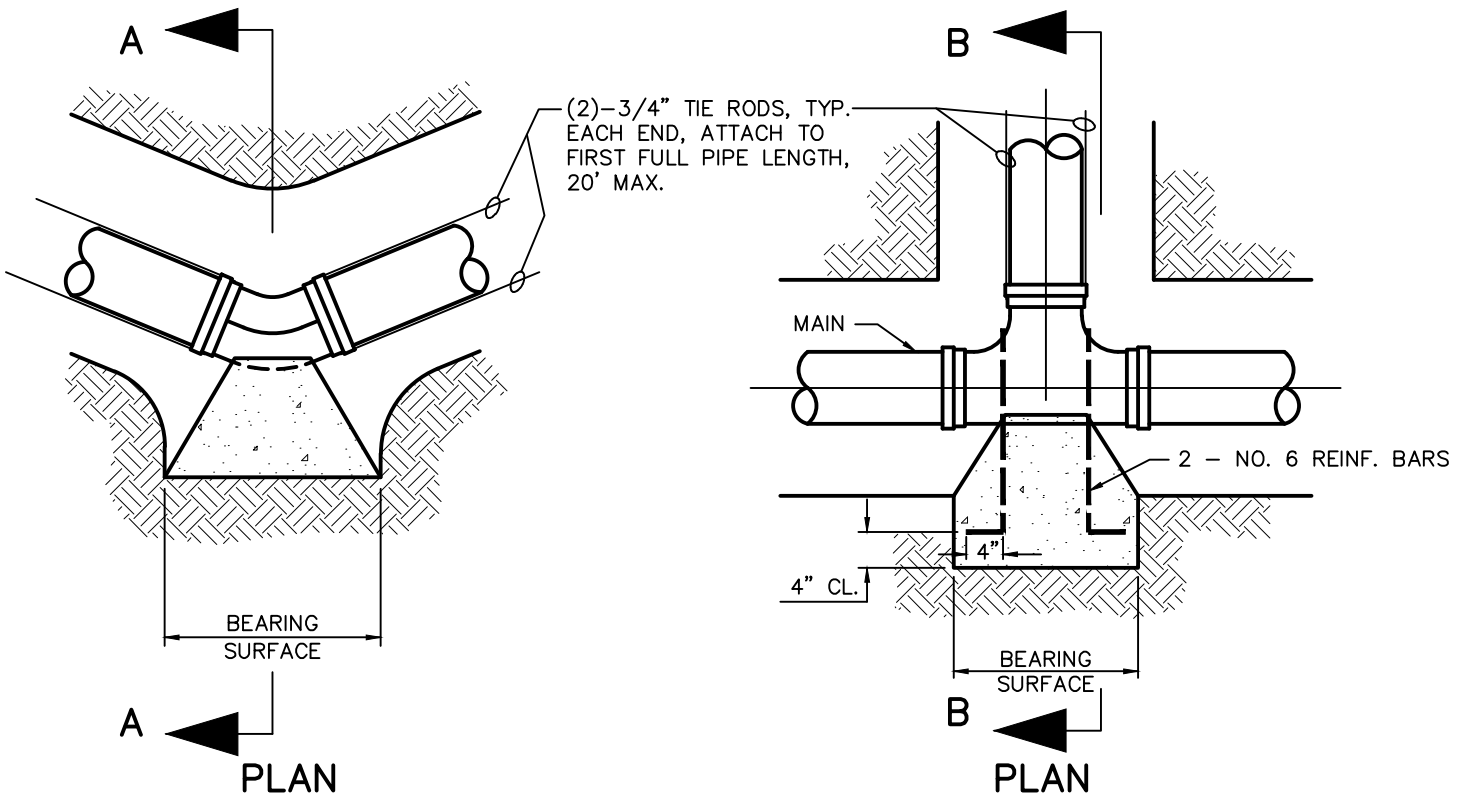

TYPICAL THRUST BLOCKING FOR HORIZONTAL & VERTICAL DOWNWARD THRUSTS UP TO 150 PSI WORKING PRESSURE

NOT TO SCALE

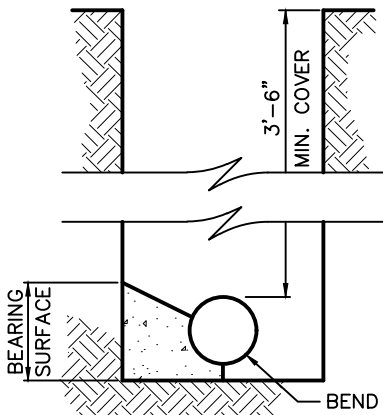

SECTION A-A

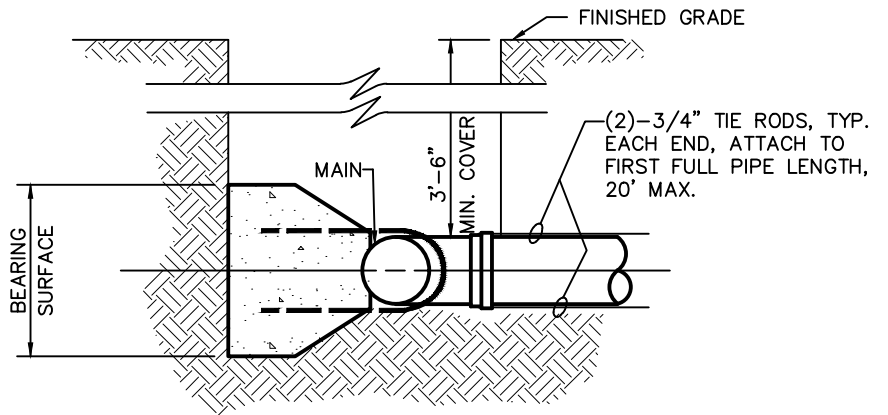

SECTION B-B

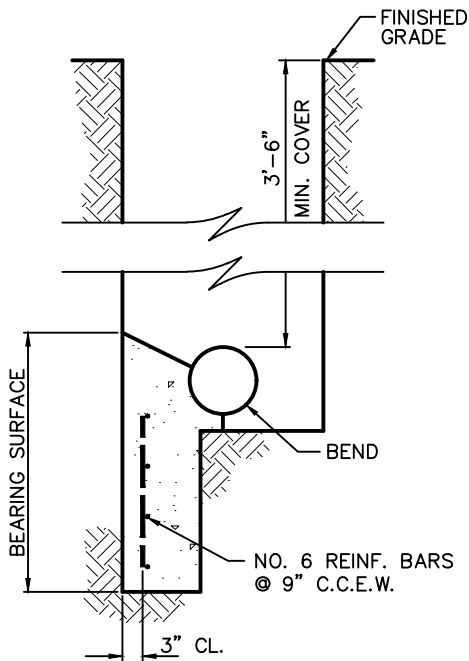

SECTION A-A

ADDITIONAL BEARING AS REQUIRED

NOTES:

1. NO COUPLING OR JOINTS SHALL BE COVERED WITH CONCRETE (WRAP IN PLASTIC).
2. REINFORCING BAR STRAPS TO BE SHAPED TO PIPE CURVATURE.
3. ALL EXPOSED STEEL TO BE PAINTED WITH TWO COATS ASPHALTIC PAINT.

**TYPICAL THRUST BLOCKING
FOR HORIZONTAL & VERTICAL
DOWNWARD THRUSTS UP TO 150 PSI WORKING PRESSURE**

NOT TO SCALE

PIPE SIZES	DIMENSIONS OF CONCRETE BLOCKING								
	LENGTH			WIDTH			DEPTH		
	11 1/4'	22 1/2'	45'	11 1/4'	22 1/2'	45'	11 1/4'	22 1/2'	45'
4" AND SMALLER	2'	4'	4'	1.5'	3'	3'	1'	2'	3'
6" AND 8"	3'	4'	6'	3'	3'	3'	2'	3'	4'
10" AND 12"	4.5'	6'	8'	3'	3'	4'	3'	4.5'	5'
14" AND 16"	6'	8'	11'	3.5'	3.5'	5'	2.5'	5'	5'
18" AND 20"	7'	9'	13'	4'	5'	5.5'	4'	5'	6'

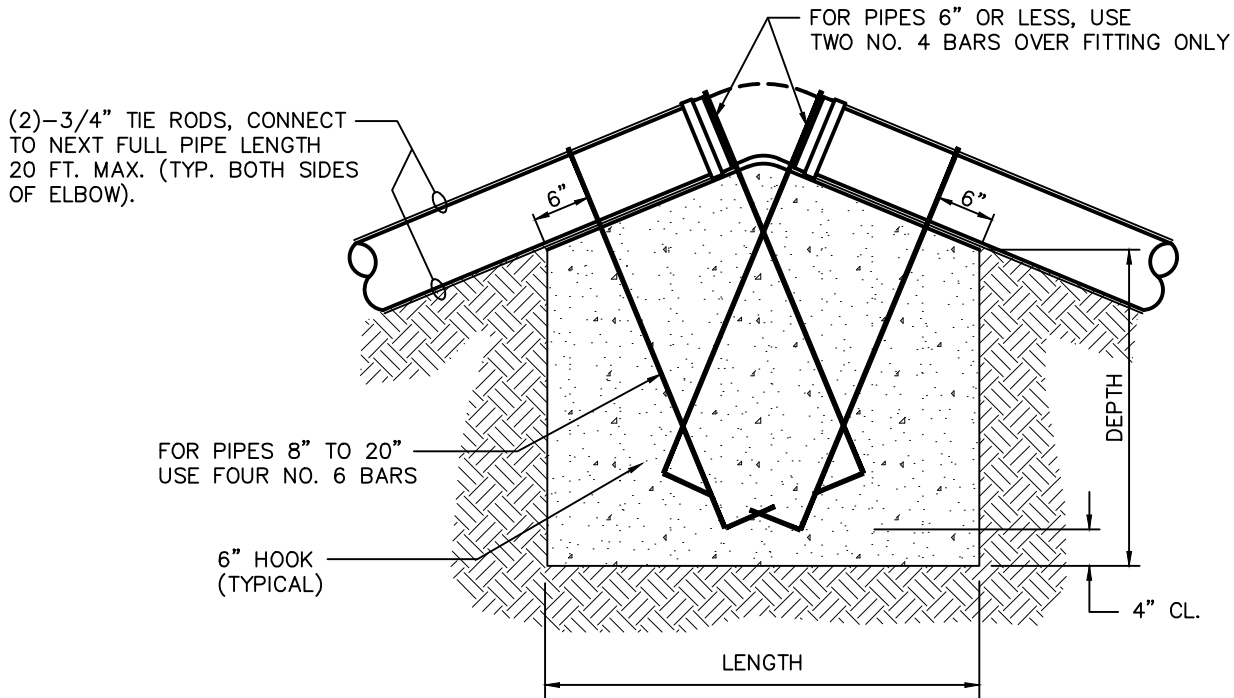

TYPICAL SECTION

NOTES:

1. NO COUPLING OR JOINTS SHALL BE COVERED WITH CONCRETE (WRAP W/ PLASTIC).
2. REINFORCING BAR STRAPS TO BE SHAPED TO PIPE CURVATURE.
3. ALL EXPOSED STEEL TO BE PAINTED WITH TWO COATS ASPHALTIC PAINT.

**THRUST BLOCKING
VERTICAL THRUSTS UPWARD UP TO
150 PSI WORKING PRESSURE**

NOT TO SCALE

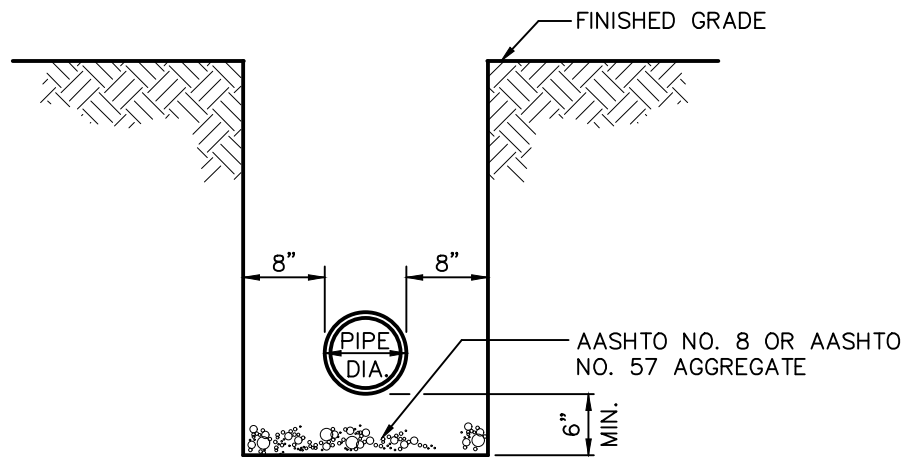

TYPICAL TRENCH

NOT TO SCALE

NOTE:

1. ALL FORCE MAIN AND LOW PRESSURE LINE PIPE TO BE INSTALLED WITH DOUBLE TRACER WIRE.

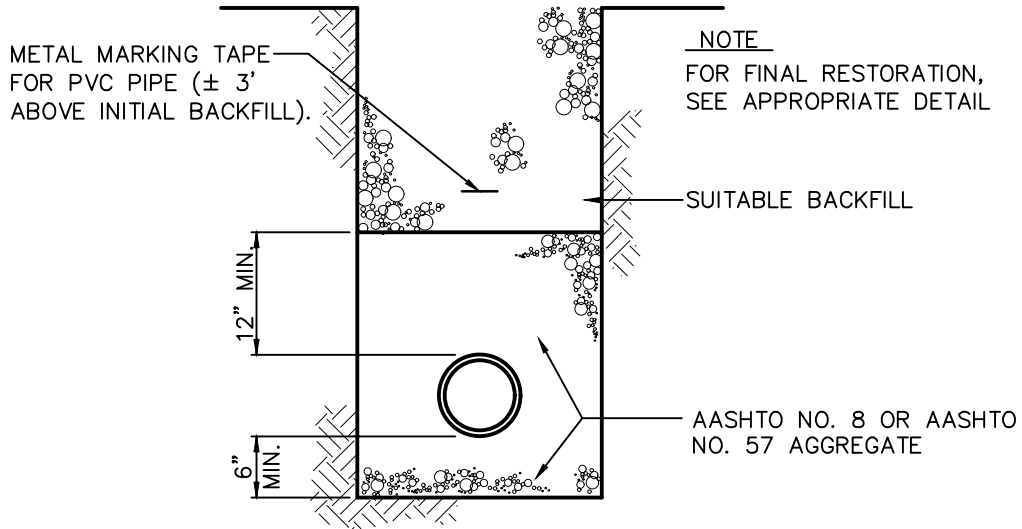

**TYPICAL BACKFILL
(OTHER THAN PAVED AREAS)**

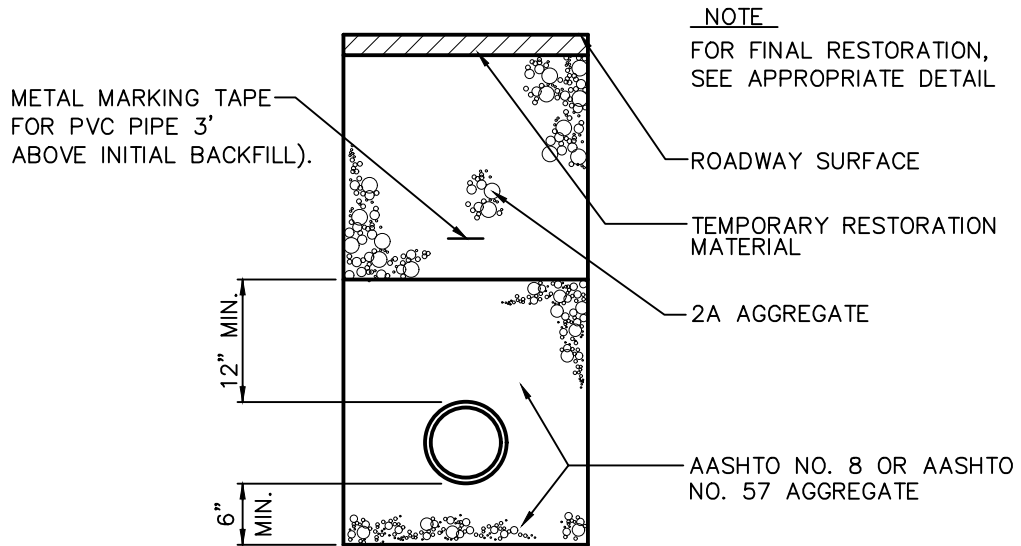

**TYPICAL BACKFILL
(ALL PAVED AREAS)**

NOTE:

1. ALL FORCE MAIN AND LOW PRESSURE LINE PIPE TO BE INSTALLED WITH DOUBLE TRACER WIRE.
2. ALL MATERIALS SHALL CONFORM TO PennDOT PUBLICATION 408, SECTION 703.3, LATEST EDITION.

PIPE BEDDING AND INTIAL BACKFILL – THIS MATERIAL SHALL CONSIST OF NO. 8 OR NO. 57 COARSE AGGREGATE.

SUITABLE BACKFILL – THIS MATERIAL SHALL CONSIST OF EXCAVATED MATERIAL FREE FROM CINDERS, ASHES, REFUSE, VEGETABLE OR ORGANIC MATERIAL, BOULDERS, ROCKS NO LARGER THAN FOUR (4) INCHES IN DIMENSION, STONE OR OTHER MATERIAL WHICH IN THE OPINION OF THE ENGINEER IS UNSUITABLE.

TYPICAL TRENCH BACKFILL

NOT TO SCALE

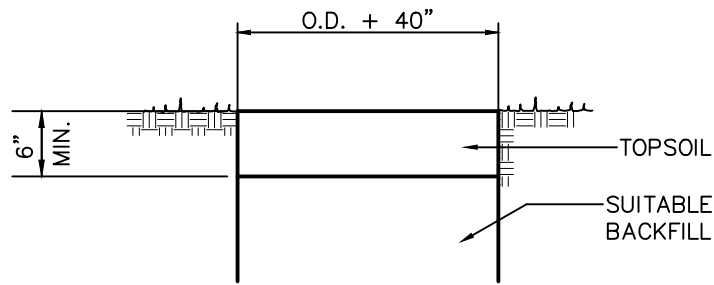

LAWN RESTORATION DETAIL

NOT TO SCALE

NOTE:
MATCH EXISTING WIDTH
OF DRIVEWAY

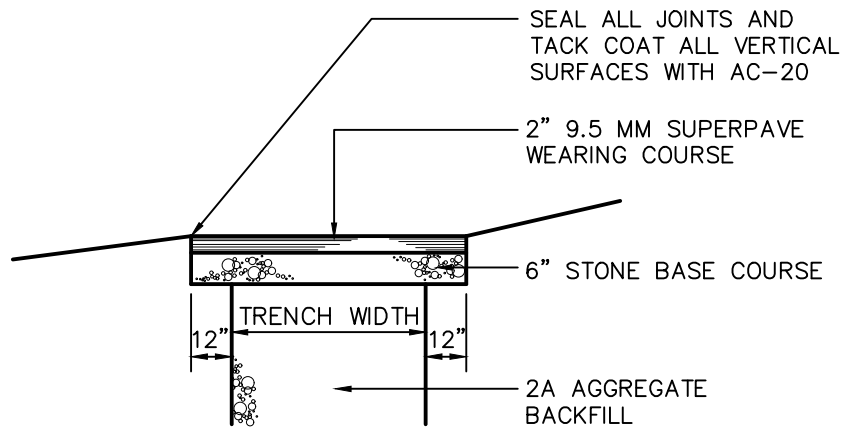

PAVED DRIVEWAY RESTORATION

NOT TO SCALE

NOTE:
MATCH EXISTING
WIDTH OF DRIVEWAY

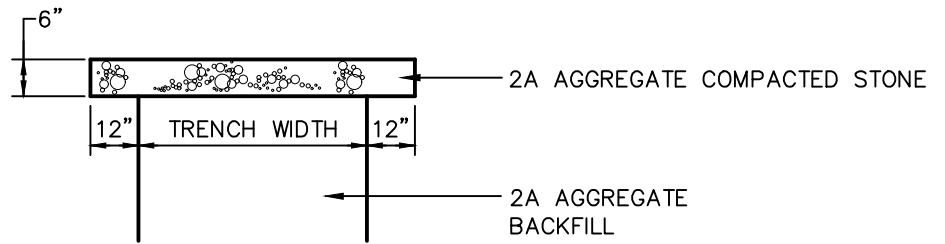

STONE DRIVEWAY RESTORATION

NOT TO SCALE

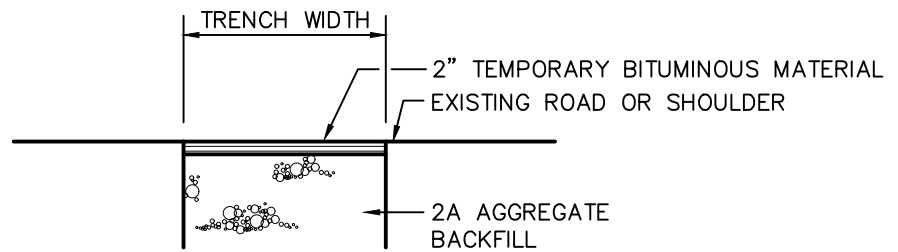

TEMPORARY BOROUGH ROADWAY
AND SHOULDER RESTORATION

NOT TO SCALE

NOTES

- ALL VERTICAL CUTS SHALL BE SAWCUT ONLY
- MATERIAL AND PLACEMENT FOR COARSE AND FINE AGGREGATES SHALL BE IN ACCORDANCE WITH PENNDOT SPECIFICATIONS PUBLICATIONS 408, LATEST EDITION.

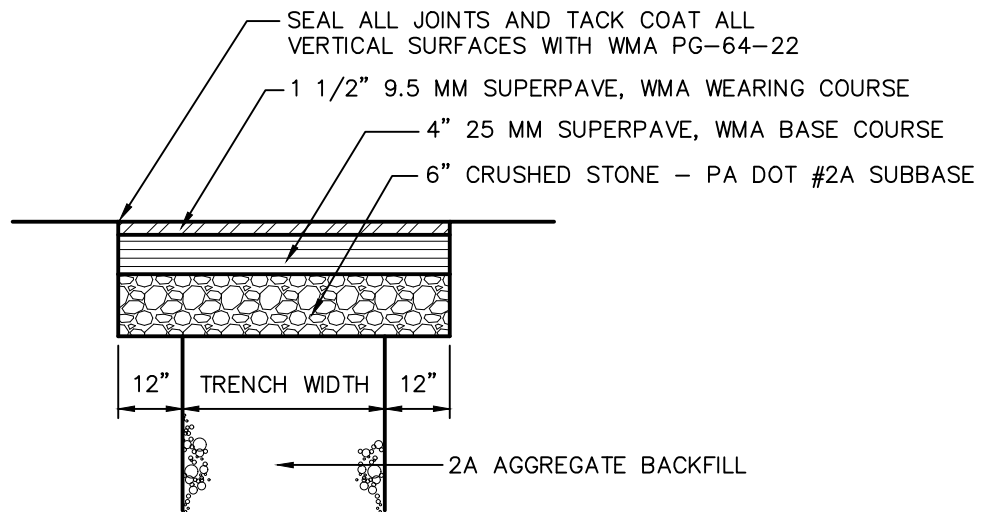

PERMANENT BOROUGH ROADWAY AND SHOULDER RESTORATION

NOT TO SCALE

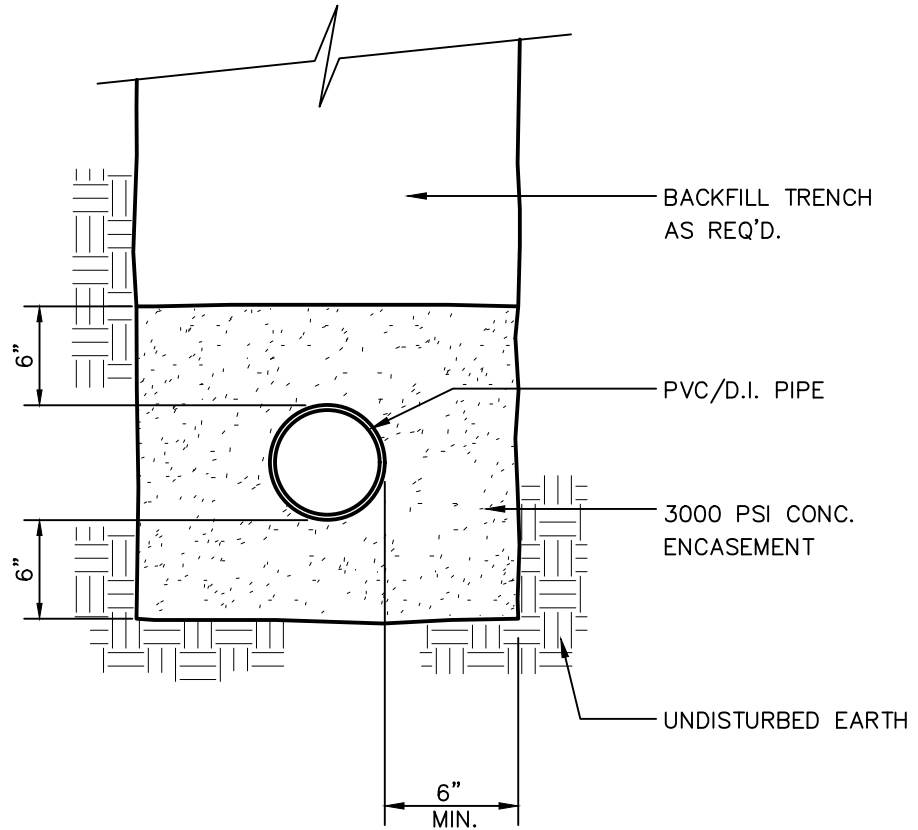

NOTE:

1. ALL FORCE MAIN AND LOW PRESSURE LINE PIPE TO BE INSTALLED WITH TRACER WIRE.

CONCRETE ENCASEMENT

NOT TO SCALE

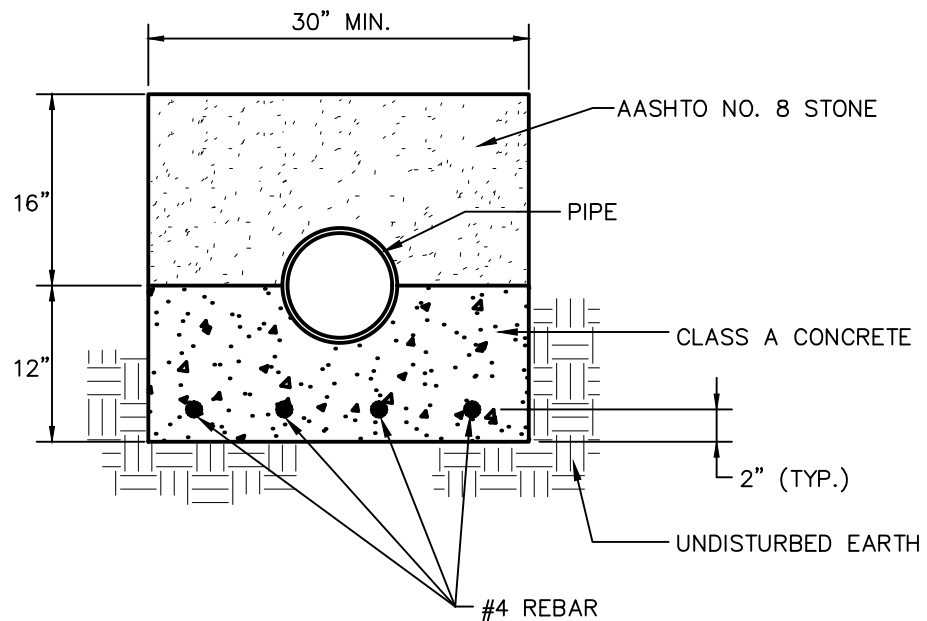

NOTES:

1. FOR USE ONLY WITH AUTHORITY'S SPECIFIC APPROVAL.
2. THE LENGTH OF CONCRETE SHALL EXTEND 10- FEET ON BOTH SIDES OF THE DEPRESSION.
3. FIELD ADJUSTMENTS MAY BE NECESSARY.
4. ALL FORCE MAIN AND LOW PRESSURE LINE PIPE TO BE INSTALLED WITH TRACER WIRE.

CONCRETE CRADLE

NOT TO SCALE

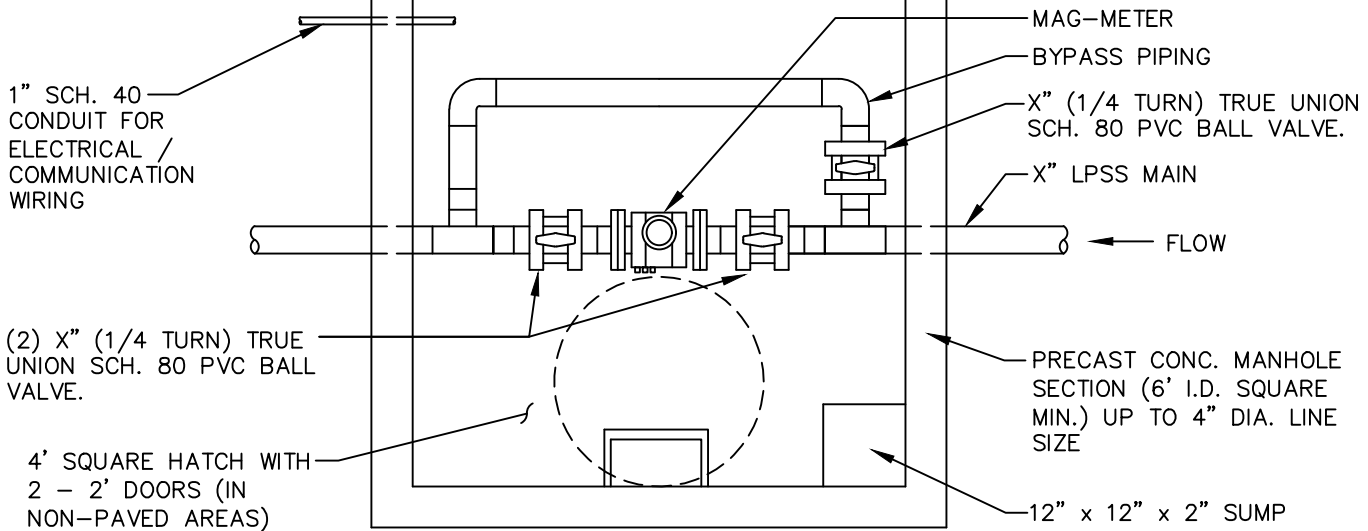

PLAN

INSTALL WRAPIDSEAL OR APPROVED EQUAL ON ALL PRECAST MANHOLE RISER RINGS AND MANHOLE FRAME JOINT (TYP.).

CONSEAL CS-102B (SEE SPEC. SECTION 02730)

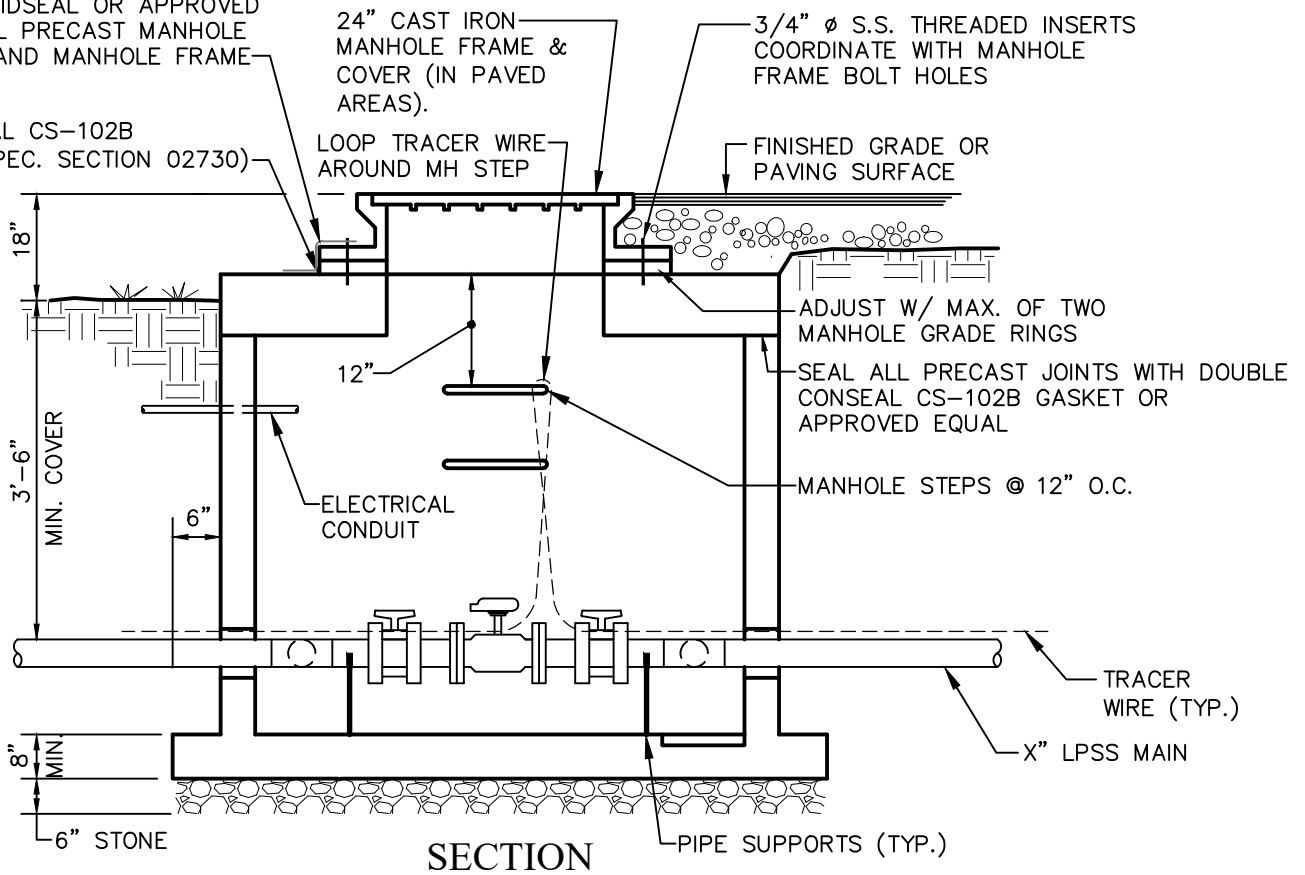

SECTION

NOTES:

1. MECHANICALLY VIBRATED PRECAST CONCRETE, RISER AND TOP SHALL CONFORM TO A.S.T.M. SPEC. C-478.
2. MANHOLE SHALL HAVE 2 COATS BITUMASTIC COATING ON EXTERIOR.
3. ALL OPENINGS AROUND PIPES SHALL BE FINISHED WITH NON-SHRINK GROUT.
4. ALL MANHOLE FOOTINGS TO BE UNDISTURBED EARTH W/ CRUSHED AGGREGATE UP TO PIPE INVERTS. MANHOLES TO BE OPEN TO DRAIN.
5. LOOP (24" MIN.) TRACER WIRE IN MANHOLE.
6. MAG-METER SIZE WILL BE BASED ON PROJECTED FLOWS.
7. FOR USE ONLY WITH AUTHORITY'S SPECIFIC APPROVAL.
8. CONTRACTOR SHALL FURNISH AND INSTALL A XX" KROHNE MAG-METER (OR APPROVED EQUAL).
9. CONTRACTOR SHALL SUPPLY AND INSTALL AN EASTECH FLOW CONTROLS-VANTAGE DUAL CHANNEL ULTRASONIC LEVEL FLOW METER.
10. CONTRACTOR SHALL SUPPLY AND INSTALL SENSAPHONE SENTINEL MONITORING SYSTEM WITH CELLULAR MODEM OPTION.
11. THE EASTECH AND SENSAPHONE DEVICES SHALL BE INSTALLED INSIDE A HOFFMAN TYPE 4 WALL MOUNT (CONTINUOUS HINGE WITH CLAMPS), NEMA 4, STAINLESS STEEL ENCLOSURE. SEE RECORDER MOUNTING DETAIL.
12. INSTALLATION OF METERING EQUIPMENT MAY REQUIRE SPECIAL AGREEMENT WITH THE AUTHORITY.

METERING MANHOLE (FORCE MAIN)

NOT TO SCALE

DATE: APRIL 2025

GENERAL NOTES:

1. FOR USE ONLY WITH AUTHORITY'S SPECIFIC APPROVAL.
2. CONTRACTOR SHALL FURNISH AND INSTALL A XX" PALMER BOWLUS FLUME. THE MANHOLE SHALL BE 5' DIAMETER (MINIMUM). THE FLUME SHALL BE SET LEVEL AND CONTRACTOR SHALL PROVIDE PIPE STUB ENDS WITH FLEXIBLE NEOPRENE COUPLING AND S.S. BAND CLAMPS.
3. CONTRACTOR SHALL SUPPLY AND INSTALL A SIGMA CONTROLS (MODEL 6200 MP) PRESSURE SENSOR LEVEL FLOW METER.
4. CONTRACTOR SHALL SUPPLY AND INSTALL OMNISITE MULTI-CHANNEL DATA MONITORING SYSTEM WITH CELLULAR MODEM OPTION.
5. THE SIGMA CONTROLS AND OMNISITE DEVICES SHALL BE INSTALLED INSIDE A HOFFMAN TYPE 4 WALL MOUNT (CONTINUOUS HINGE WITH CLAMPS), NEMA 4, STAINLESS STEEL ENCLOSURE. SEE RECORDER MOUNTING DETAIL.
6. INSTALLATION OF METERING EQUIPMENT WILL BE CLARIFIED UNDER SPECIAL AGREEMENT.

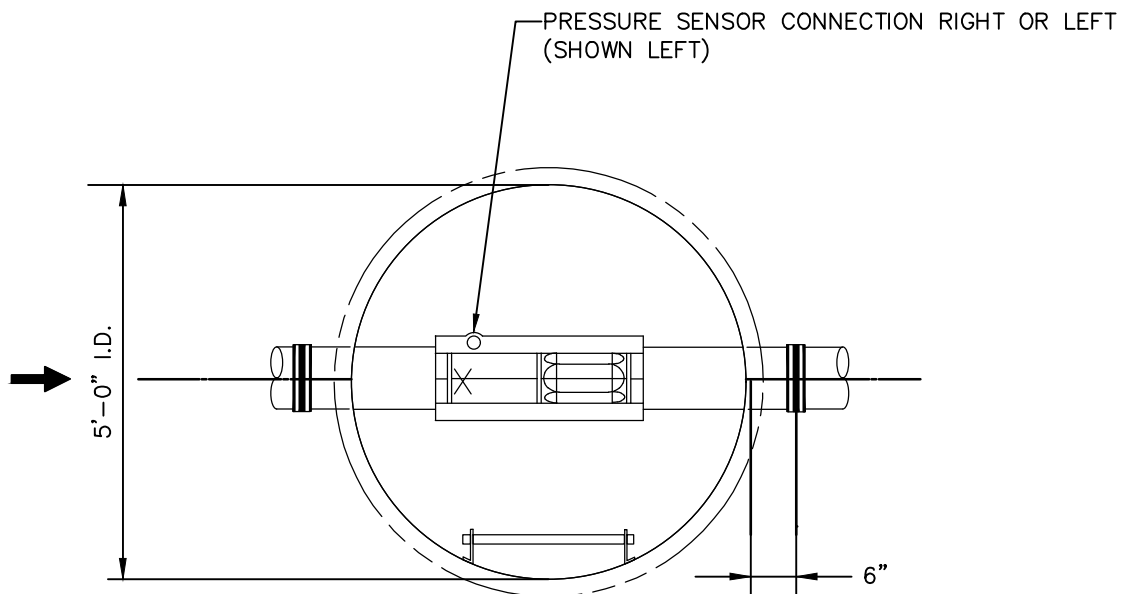

METERING MANHOLE (GRAVITY)

NO SCALE

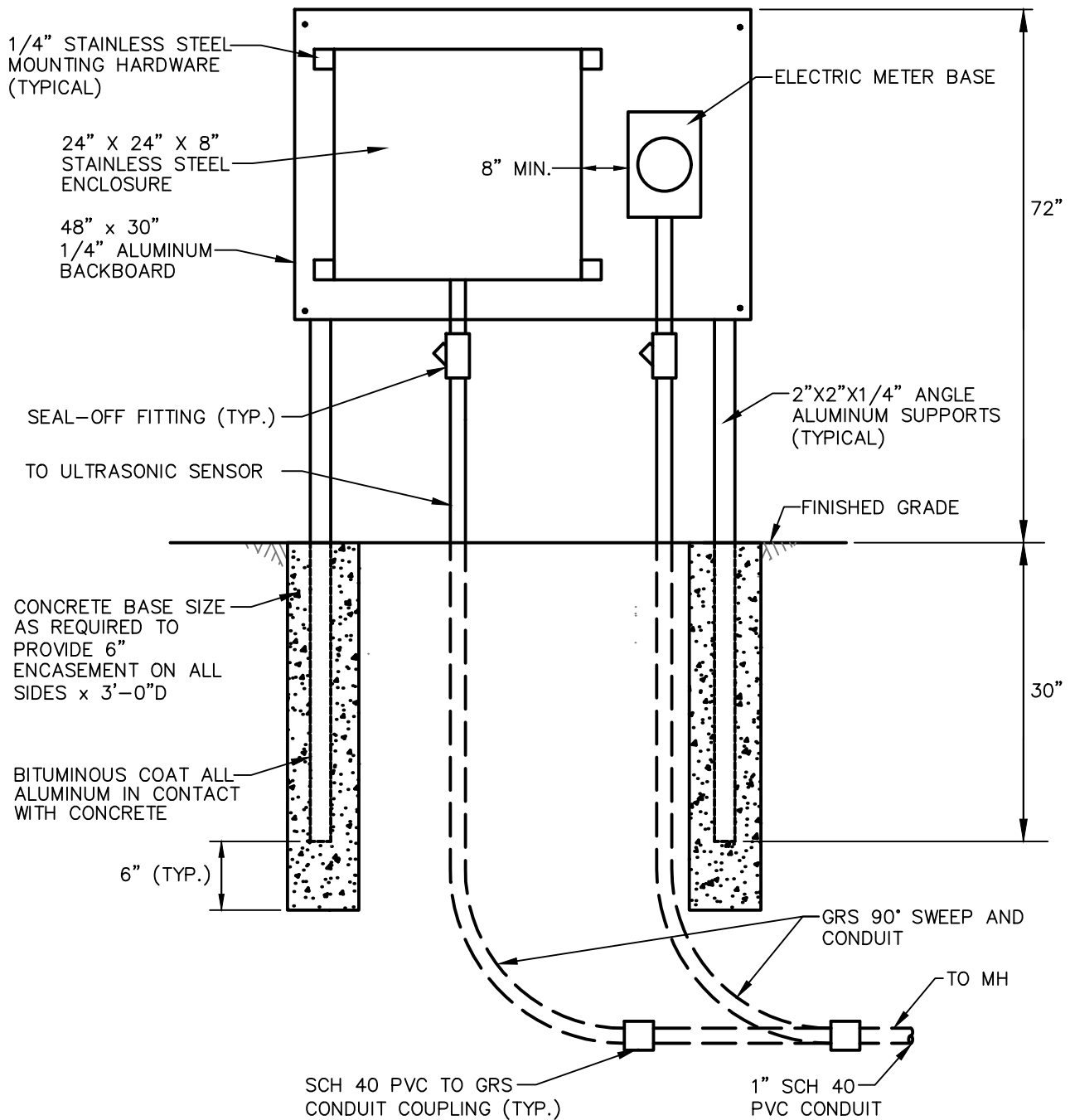

NOTE:

1. FOR USE ONLY WITH AUTHORITY'S SPECIFIC APPROVAL.
2. ALL MATERIALS AND CONSTRUCTION SHALL BE COMPLETED IN ACCORDANCE WITH APPLICABLE BUILDING AND ELECTRICAL CODES

RECORDER MOUNTING DETAIL

NOT TO SCALE

SPACING: GRADES 20% UP TO 35% – NOT OVER 36FT C.T.C.
 GRADES 35% UP TO 50% – NOT OVER 24FT C.T.C.
 GRADES 50% AND OVER – NOT OVER 16FT C.T.C.

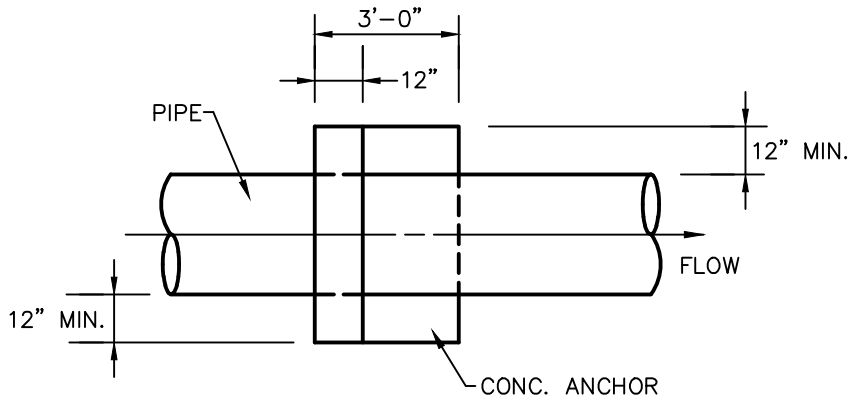

PLAN

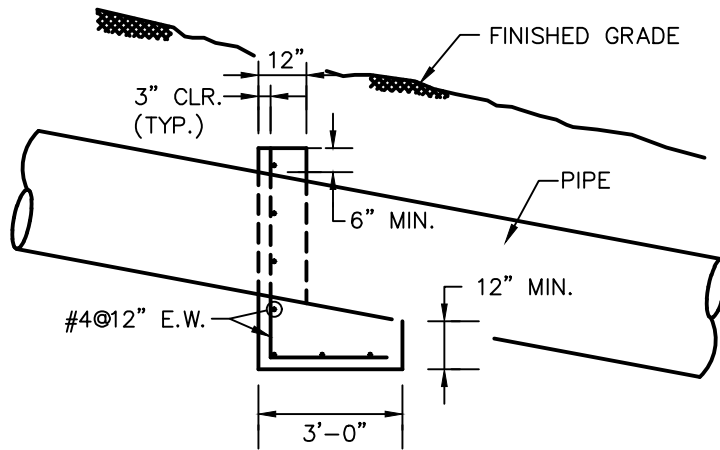

SECTION

TYP. CONCRETE ANCHOR DETAIL FOR 8" THRU 36" SEWERS

NOT TO SCALE

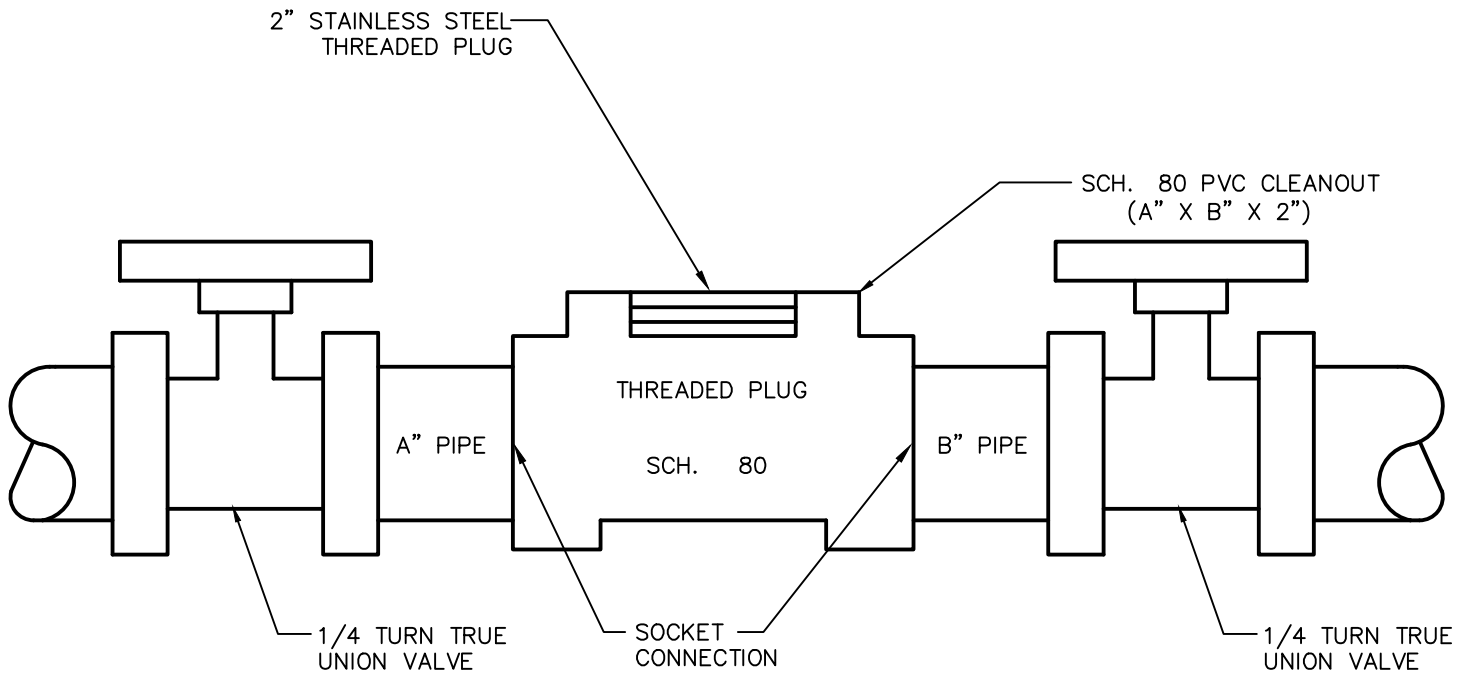

LOW PRESSURE CLEANOUT

NOT TO SCALE

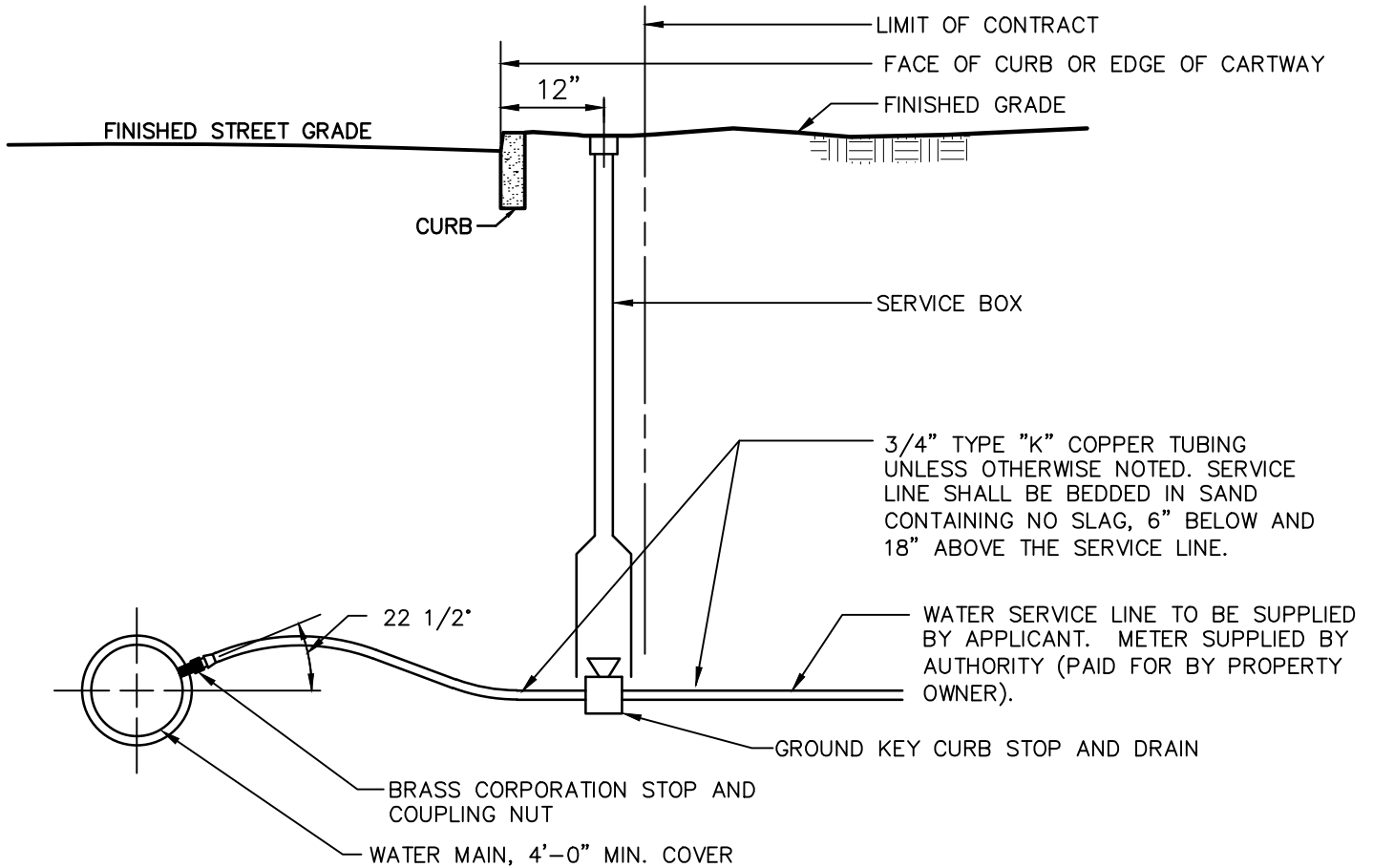

NOTES:

1. THE AUTHORITY REQUIRES THAT A WATER METERING CHAMBER BE INSTALLED FOR ALL WATER SERVICE LINES GREATER THAN 100 FEET MEASURED FROM PUBLIC RIGHT-OF-WAY TO FACE OF BUILDING ALONG THE WATER SERVICE LINE. THIS APPLIES TO BOTH RESIDENTIAL AND COMMERCIAL INSTALLATIONS. THE WATER METERING CHAMBER SHALL BE INSTALLED AT THE RIGHT-OF-WAY LINE OR ALTERNATE LOCATION APPROVED BY THE AUTHORITY.
2. WATER METERING CHAMBERS SHALL BE REVIEWED AND APPROVED BY THE AUTHORITY.

**STANDARD
DOMESTIC SERVICE INSTALLATION**

NOT TO SCALE

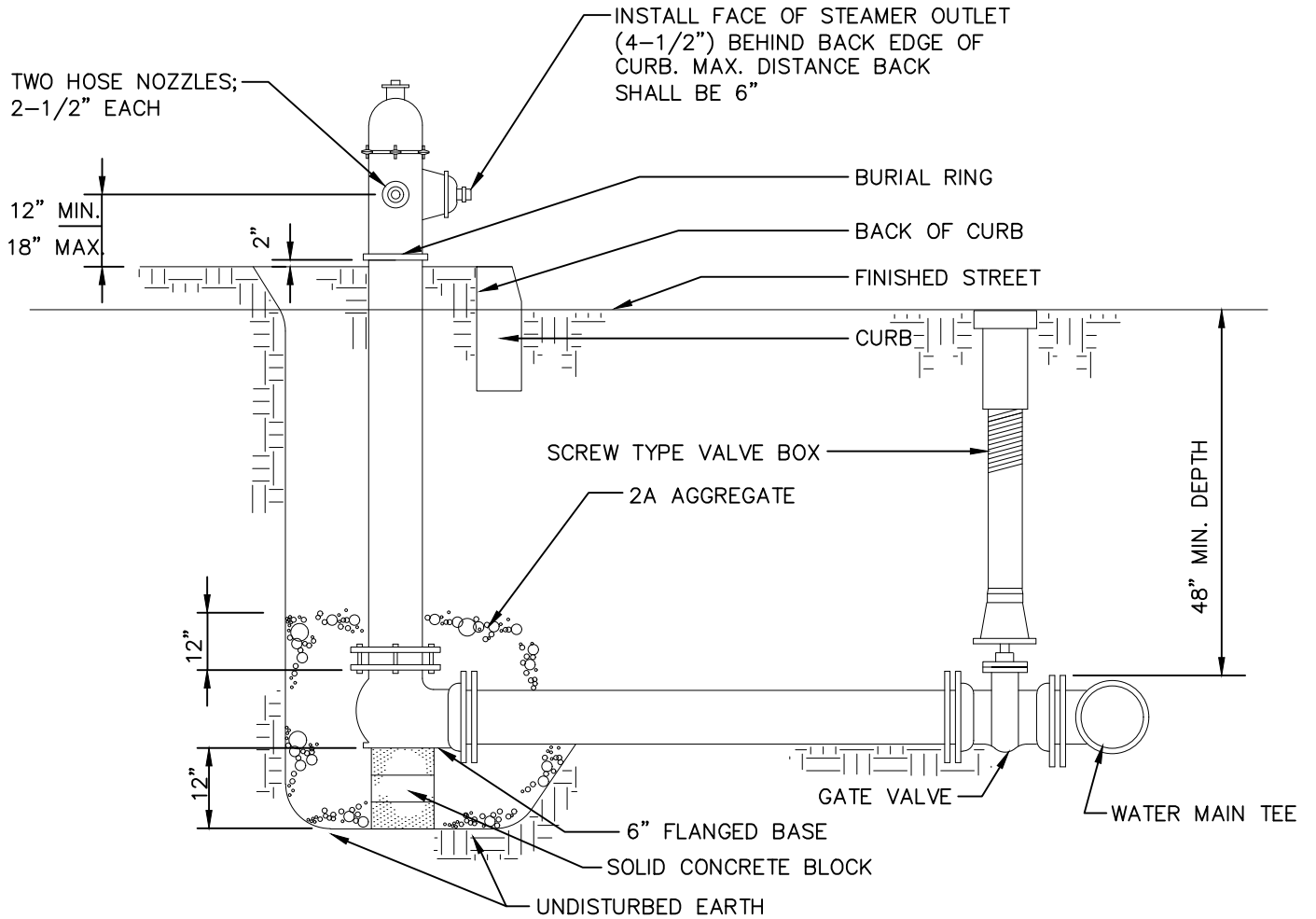

NOTES:

1. HYDRANT SHALL BE PAINTED AS REQUIRED BY AUTHORITY.
2. HYDRANT SHALL MEET UL-FM STANDARD SPECIFICATIONS.
3. HYDRANT SHALL BE KENNEDY MODEL K81-D

FIRE HYDRANT SETTING

NOT TO SCALE

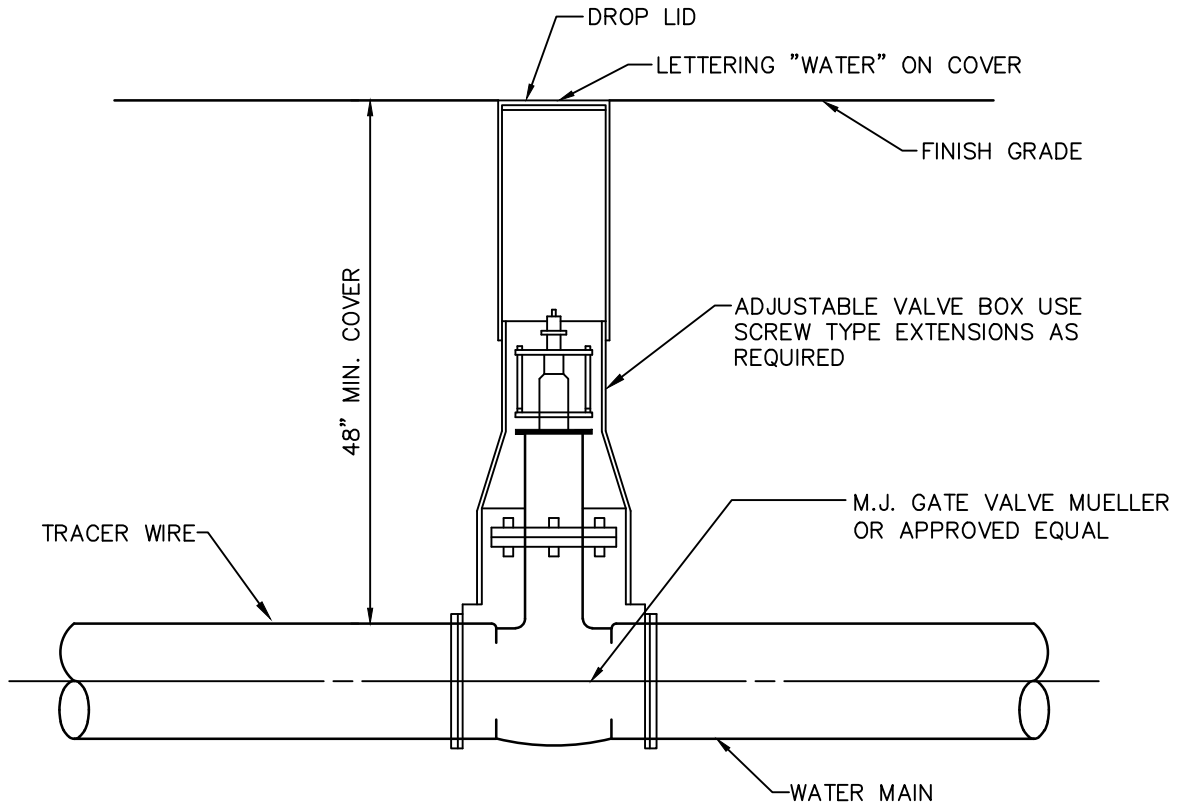

NOTE: IF EXTENSIONS ARE NECESSARY
CONTRACTOR SHALL SET "PLUMB"
AND ALIGN PROPERLY FOR ACCESS TO
OPERATING NUT.

TYPICAL GATE VALVE & VALVE BOX

NOT TO SCALE

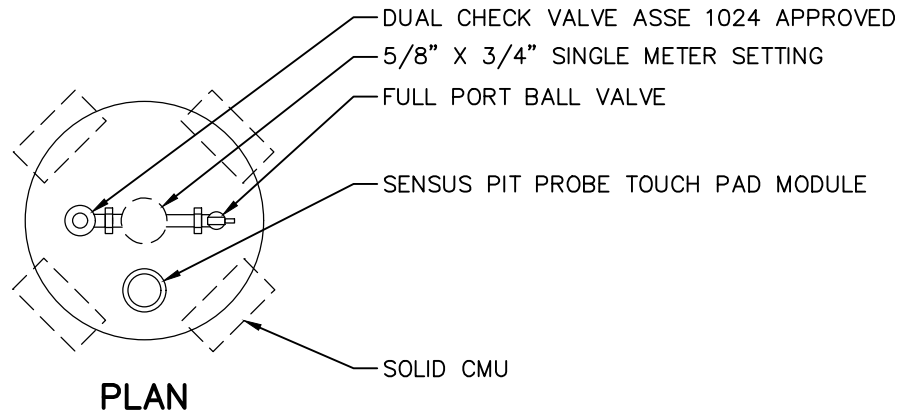

PLAN

NOTES:

1. FORD COIL PIT SETTER OR APPROVED EQUAL.
2. BRASS CONNECTIONS CONFORM TO ASTM C800.
3. BRASS VALVES & FITTINGS NSF/ANSI 61 APPROVED.

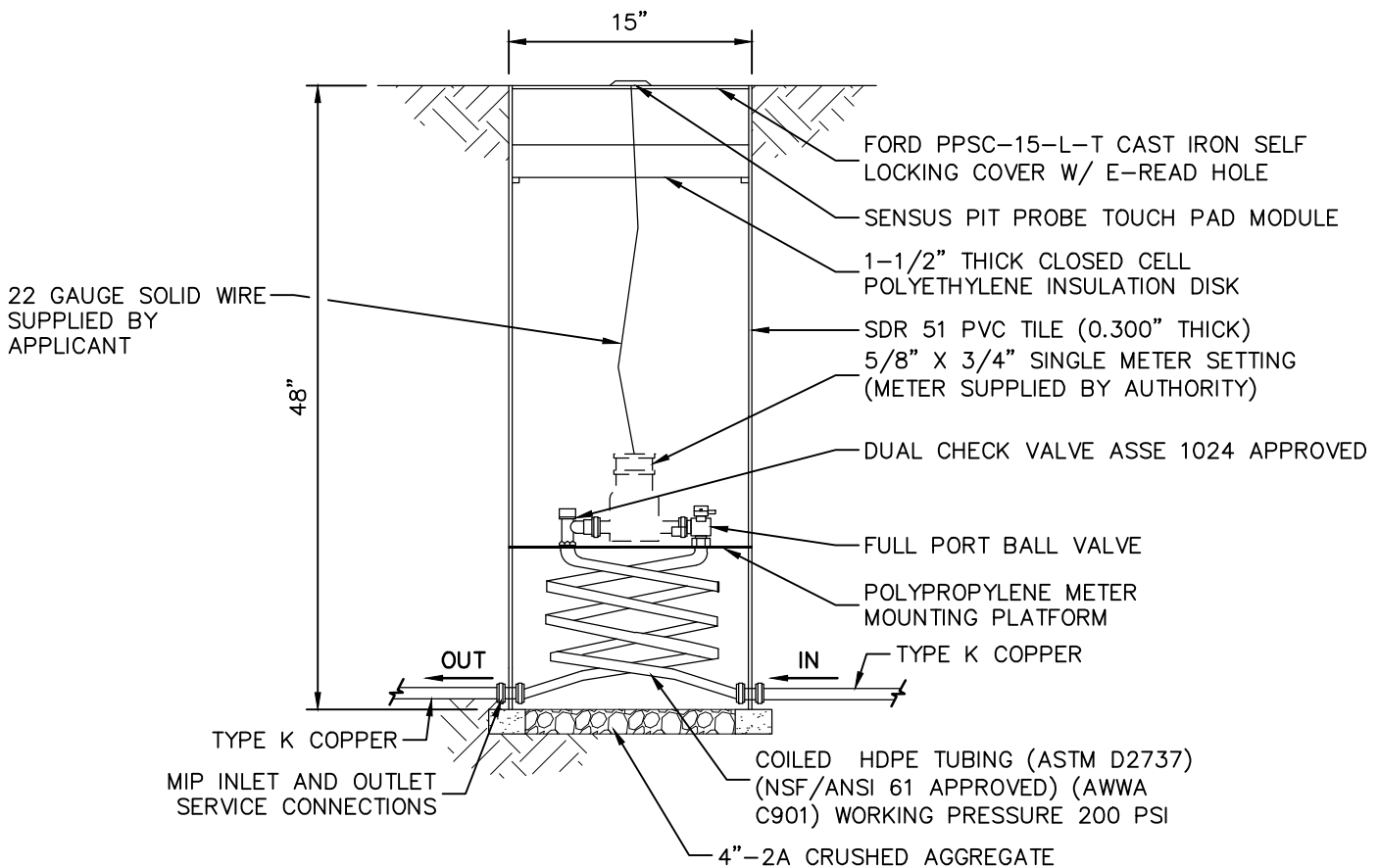

SECTION

NOTES:

1. THE AUTHORITY REQUIRES THAT A WATER METERING CHAMBER BE INSTALLED FOR ALL WATER SERVICE LINES GREATER THAN 100 FEET MEASURED FROM PUBLIC RIGHT-OF-WAY TO FACE OF BUILDING ALONG THE WATER SERVICE LINE. THIS APPLIES TO BOTH RESIDENTIAL AND COMMERCIAL INSTALLATIONS. THE WATER METERING CHAMBER SHALL BE INSTALLED AT THE RIGHT-OF-WAY LINE OR ALTERNATE LOCATION APPROVED BY THE AUTHORITY.
2. WATER METERING CHAMBERS SHALL BE REVIEWED AND APPROVED BY THE AUTHORITY.
3. OTHER SIZES SHALL BE REVIEWED ON A CASE BY CASE BASIS.

STANDARD 3/4" METERING CHAMBER

NO SCALE

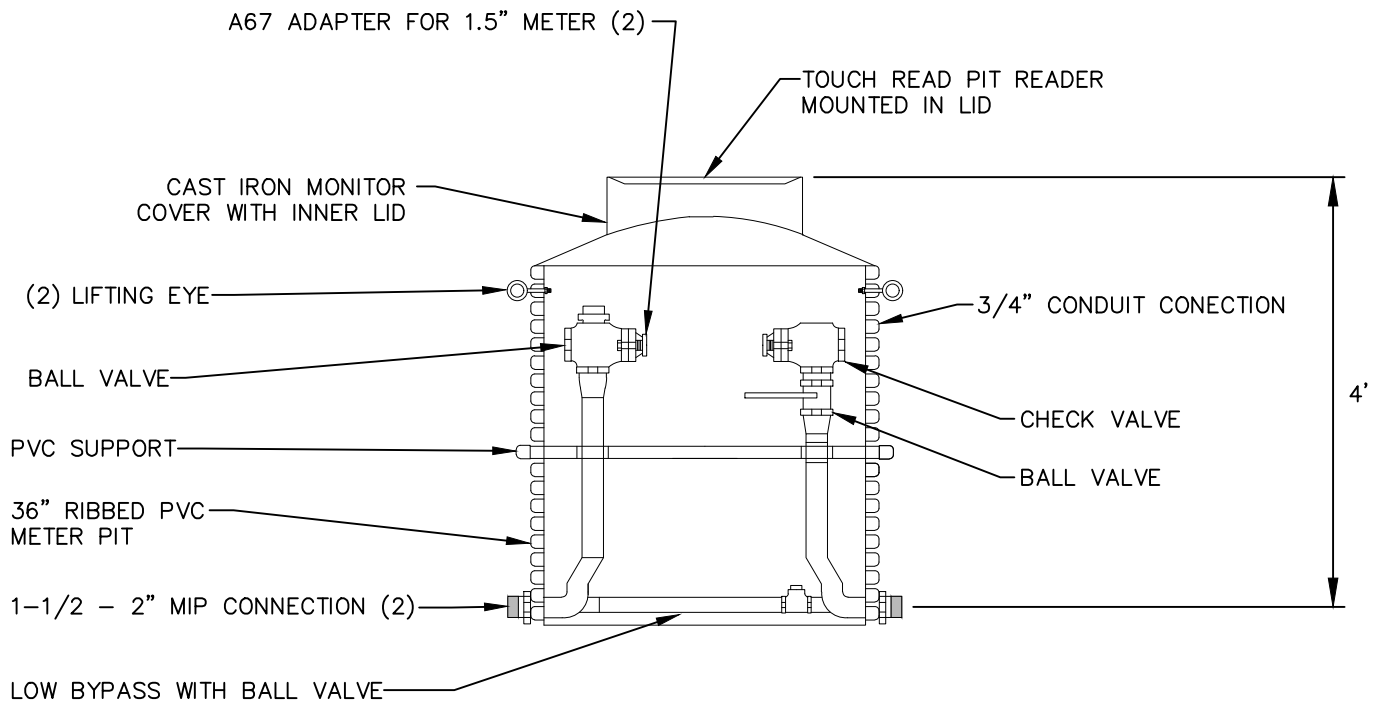

1. METER PIT PN# 2-SINGLEPIT (PMBHH788-DWG-95565-C)
 2. COVER PN# MC-36-MB
 3. ADAPTERS FOR 1-1/2" METER PN# A67 (NOT REQUIRED FOR 2" METER)
 4. CONNECTORS FOR 2" COPPER, PN#C14-77-Q
 5. CONNECTORS FOR 1-1/2" COPPER, PN# C11-76 AND PN#C84-66-Q
- *** LOCAL SUPPLIER L/B WATER SERVICE CO. EPHRATA, PA. (717)-738-0389

1-1/2" AND 2" STANDARD METER PIT, PREPIPED

NOT TO SCALE

MINIMUM PIT SIZE - DIMENSIONS IN INCHES										
FIRELINE & DOMESTIC LINE METER SIZE	A	B	C	D	E	F	G	H	I	J
2" FIRE & 1" DOM	72	96	18	36	84	20	18	36	6	6
2" FIRE & 2" DOM	72	96	18	36	84	20	18	36	6	6
4" FIRE & 1" DOM	72	144	24	30	84	20	18	39	6	6
4" FIRE & 2" DOM	72	144	24	30	84	20	18	39	6	6
6" FIRE & 1" DOM	72	192	30	30	84	20	18	45	6	6
6" FIRE & 2" DOM	72	192	30	30	84	20	18	45	6	6
8" FIRE & 1" DOM	96	210	42	30	84	20	18	57	6	6
8" FIRE & 2" DOM	96	210	42	30	84	20	18	57	6	6
10" FIRE & 1" DOM	96	240	48	30	84	20	18	63	6	6
10" FIRE & 2" DOM	96	240	48	30	84	20	18	63	6	6

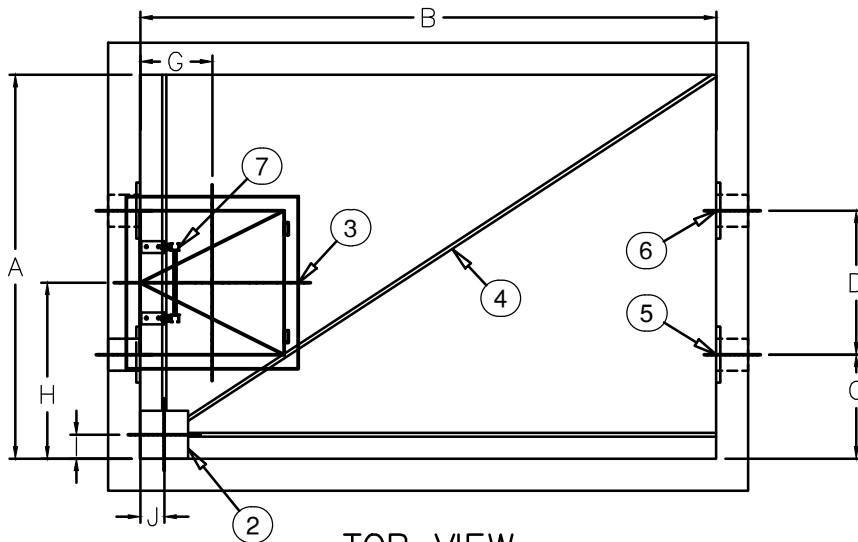

TOP VIEW

Parts List	
ITEM	NAME
1	SHIPLAP TONGUE AND GROOVE JOINT (TYP.)
2	12" X 12" X 4" DEEP SUMP
3	36" X 36" - SINGLE LEAF PENNSYLVANIA INSERT DOOR - RATED FOR EITHER NON TRAFFIC (SD DOOR) OR TRAFFIC (HD GAL. STL.)
4	(3) DRAIN CHANNEL 1" WIDE SLOPED 0" TO 1-1/2" AT SUMP
5	(2) OMNI SLEEVE FOR FIRE LINE
6	(2) HOLES FOR DOM LINE
7	PENNSYLVANIA INSERT ALUMINUM INTEGRAL LADDER W/SAFETY EXTENSION POST
PIT IS PRE-PIPED	
8	7'-0" PAI ALUM. LADDER W/BOLT ON EXTENSION POST INSTALLED IN FIELD BY CONTRACTOR.

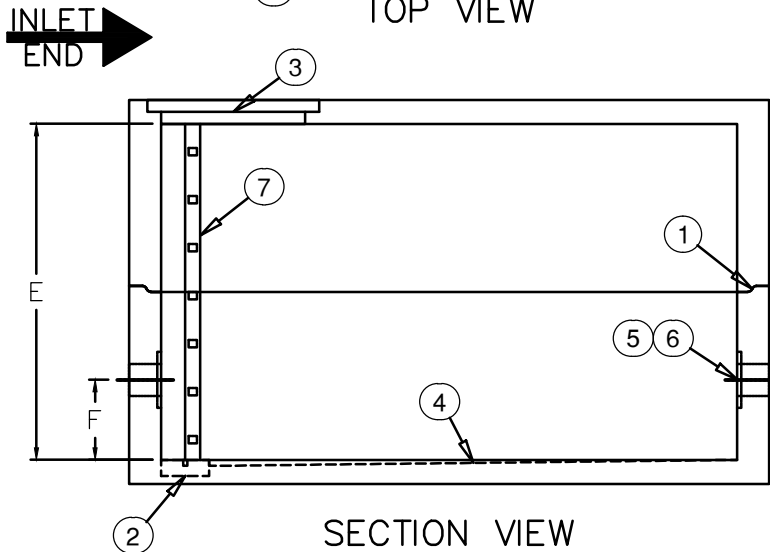

SECTION VIEW

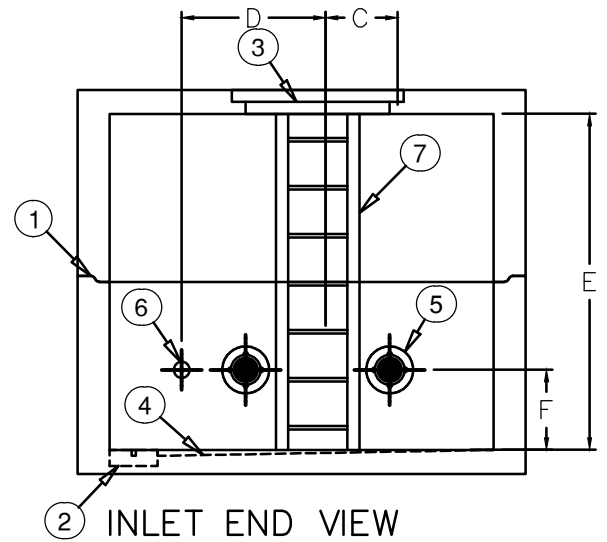

INLET END VIEW

DOUBLE WATER METER VAULT TYPE A

NOT TO SCALE

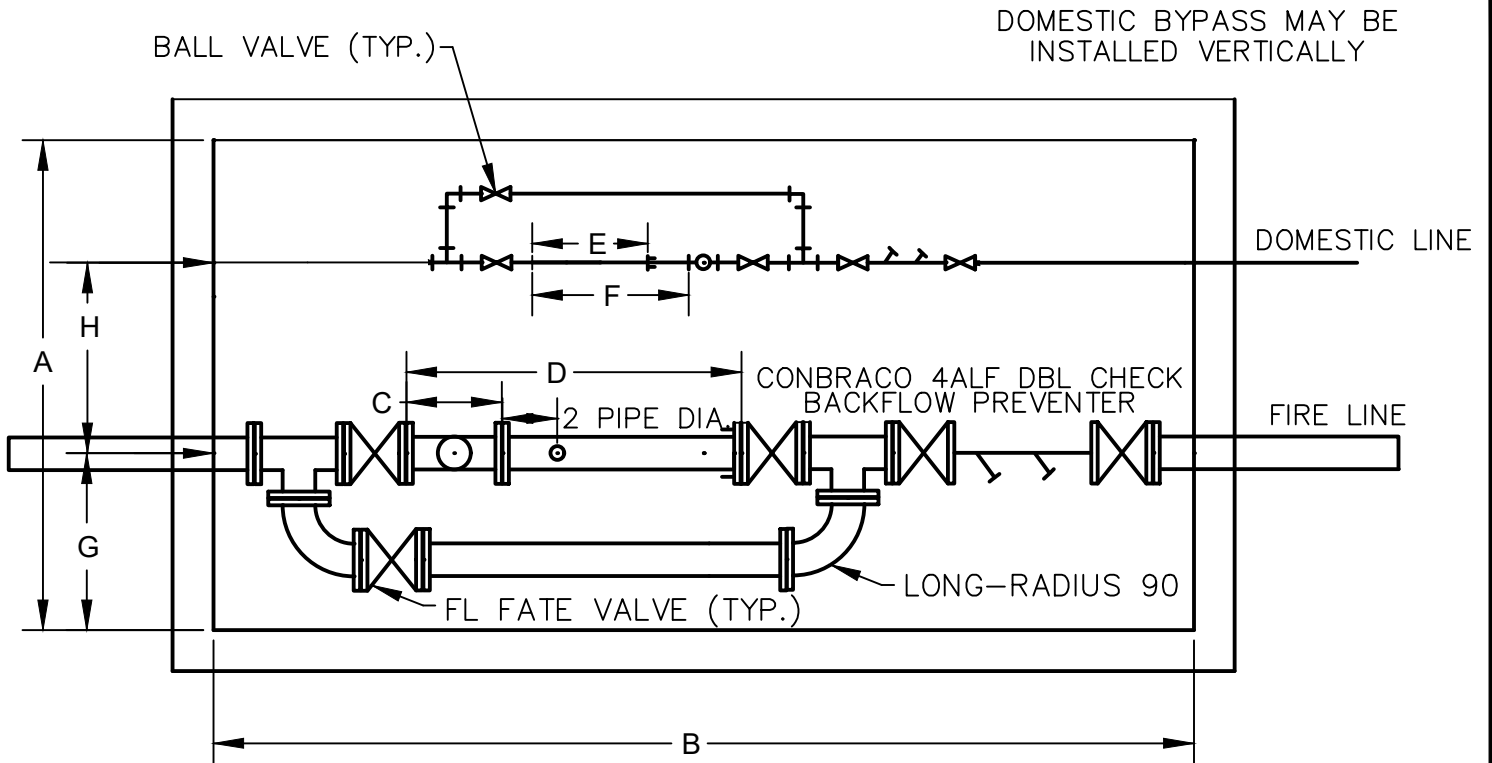

- NOTES:
 1. FIRE LINE FLOW METER TO BE SENSUS F3 FIRE METER

MINIMUM PIT SIZE - DIMENSIONS IN INCHES								
FIRELINE & DOMESTIC LINE METER SIZE	A	B	C	D	E	F	G	H
2" FIRE & 1" DOM.	72	96	17	23	10.75	16.75	18	36
2" FIRE & 2" DOM.	72	96	17	23	17	23	18	36
4" FIRE & 1" DOM.	72	144	14	48	10.75	16.75	24	30
4" FIRE & 2" DOM.	72	144	14	48	17	23	24	30
6" FIRE & 1" DOM.	72	192	18	60	10.75	16.75	30	30
6" FIRE & 2" DOM.	72	192	18	60	17	23	30	30
8" FIRE & 1" DOM.	96	210	20	68	10.75	16.75	42	30
8" FIRE & 2" DOM.	96	210	20	68	17	23	42	30
10" FIRE & 1" DOM.	96	240	17.75	84	10.75	16.75	48	30
10" FIRE & 2" DOM.	96	240	17.75	84	17	23	48	30

DOUBLE WATER METER VAULT TYPE A PIPE SCHEMATIC

NOT TO SCALE

ALUMINUM DOOR, STANDARD DUTY, SINGLE LEAF - TROUGH FRAME

- 1/4" Diamond Plate Lid Reinforced for 300 lb/ft² live load
- 6" Drain Trough Frame with Gasket
- Protective Barrier where Concrete meets Aluminum
- Continuous Anchor to Lock Frame into Concrete
- Stainless Steel Pneumatic Spring as required
- Stainless Steel Hinges
- Stainless Steel Hardware
- Type 316 Stainless Steel Snap Lock
- 1-1/2" (I.D.) Drain Coupling
- Automatic Hold Open Arm with Red Release Handle
- Flush Mounted Lift Handle

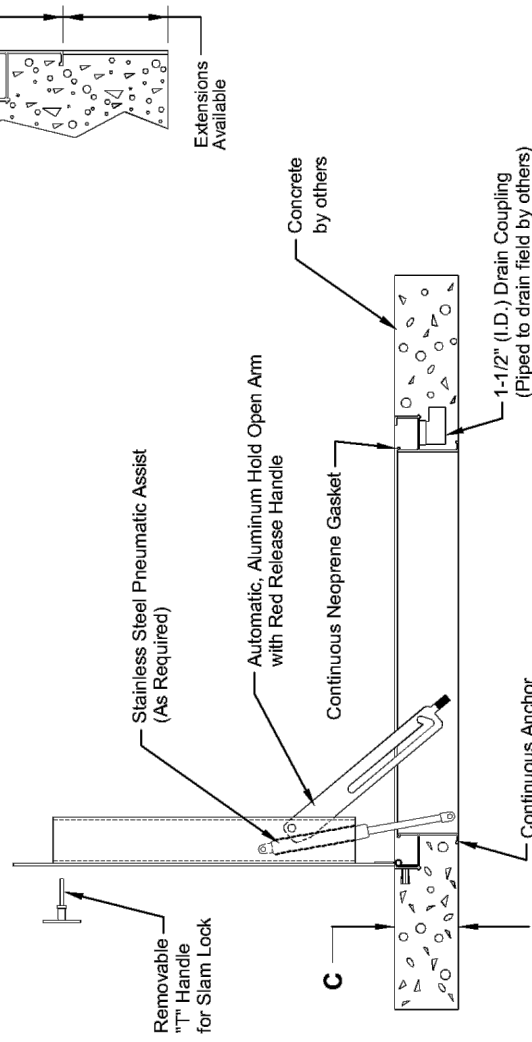
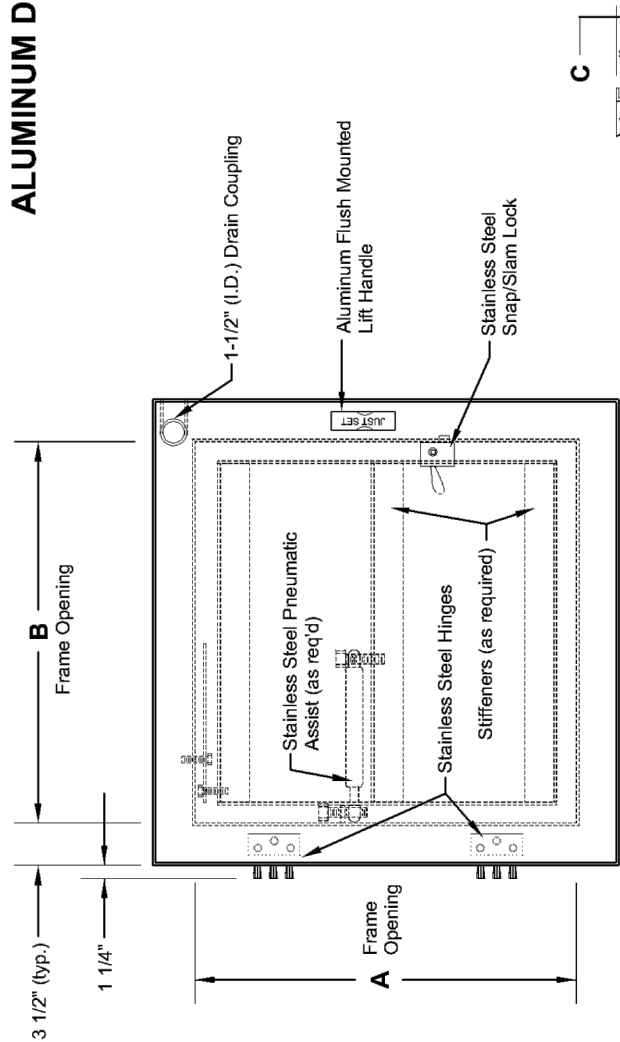

STANDARD DIMENSIONS				
QTY	A	B	C	STOCK#
 	24"	24"	6.00"	ATS2424S
 	30"	30"	6.00"	ATS3030S
 	36"	24"	6.00"	ATS3624S
 	36"	30"	6.00"	*ATS3630S
1	36"	36"	6.00"	*ATS3636S
 	42"	42"	6.00"	*ATS4242S
 	48"	36"	6.00"	*ATS4836S
 	48"	48"	6.00"	*ATS4848S

An asterisk (*) next to stock number = stainless steel pneumatic spring is standard.

NO SCALE

**Installation shall be in accordance with manufacturer's instructions

ALUMINUM WATERTIGHT DOOR, HEAVY DUTY, SINGLE LEAF

- 1/4" Diamond Plate Lid Reinforced for HS-20 Wheel Loading **(without Impact - for incidental traffic only)**
- Drain Trough Frame with Gasket
- Protective Barrier where Concrete meets Aluminum
- Continuous Anchor to Lock Frame into Concrete
- Stainless Steel Pneumatic Assist (as required)
- Stainless Steel (Butt Style) Hinges & Hinge Pin
- Stainless Steel Hardware
- Type 316 Stainless Steel Snap Lock
- 1-1/2" (I.D.) Drain Coupling
- Automatic Hold Open Arm
- Aluminum Flush Mounted Lift Handle

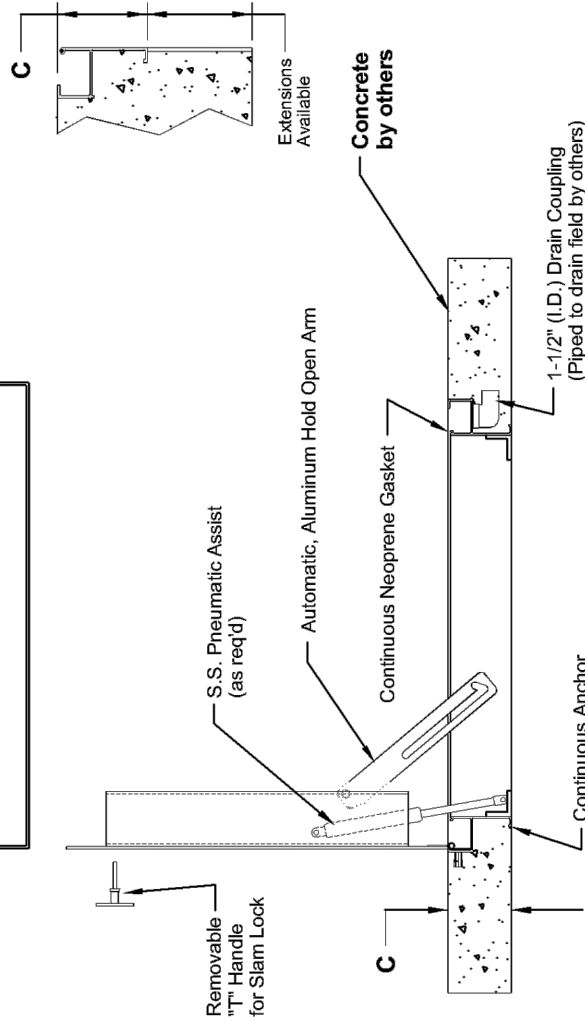
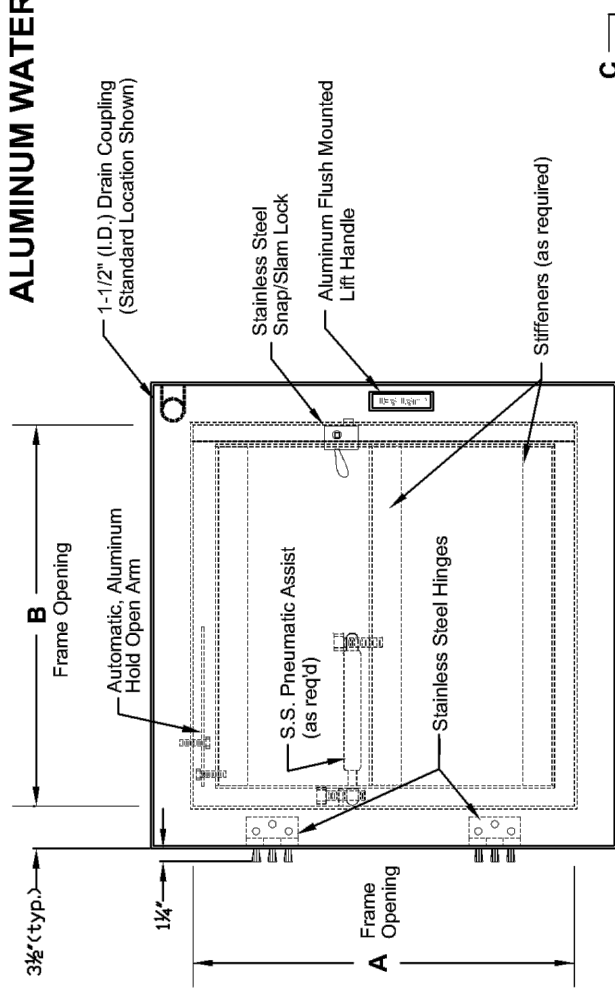

NO SCALE

Installation shall be in accordance with manufacturer's instructions

STANDARD DIMENSIONS				
QTY	A	B	C	STOCK#
X	24"	24"	6.00"	ATH2424S
X	30"	30"	6.00"	*ATH3030S
X	36"	24"	6.00"	*ATH3624S
1	36"	36"	6.00"	*ATH3636S
X	42"	42"	6.00"	*ATH4242S
X	48"	24"	6.00"	*ATH4824S
X	48"	48"	6.75"	*ATH4848S

An asterisk (*) next to stock number = stainless steel pneumatic assist is standard.

ALL MATERIALS ARE MILL FINISH ALUM. ALLOY

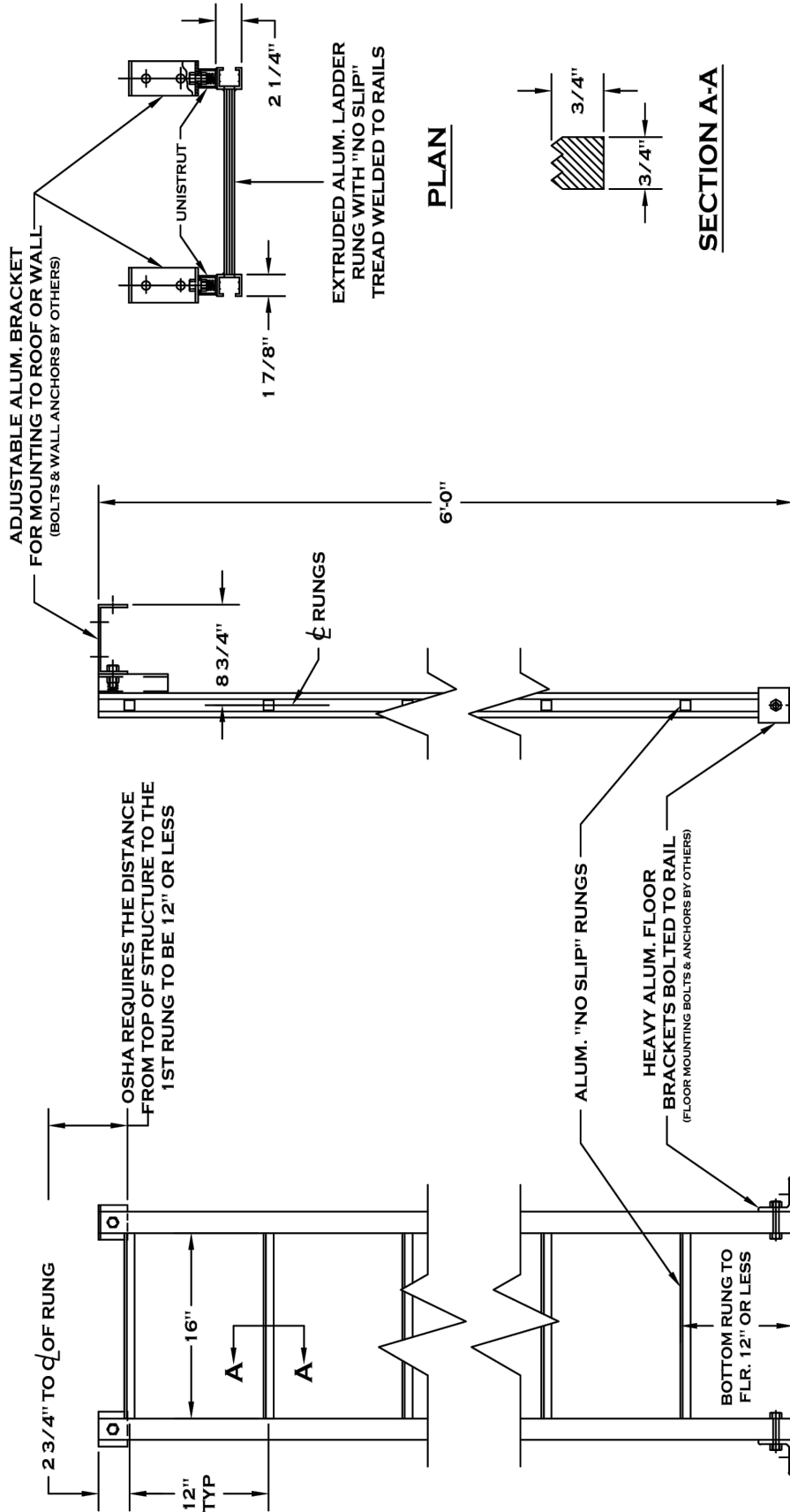

SIDE ELEVATION

ELEVATION

- OPTIONS:**
- INTEGRAL LADDER EXTENSION
 - BOLT-ON LADDER EXTENSION

NO SCALE

ALUMINUM -BOLT ON- LADDER EXTENSION

- ALL ALUMINUM CONSTRUCTION
- STAINLESS STEEL HARDWARE
- MINIMUM 5' - 0" LADDER REQUIRED

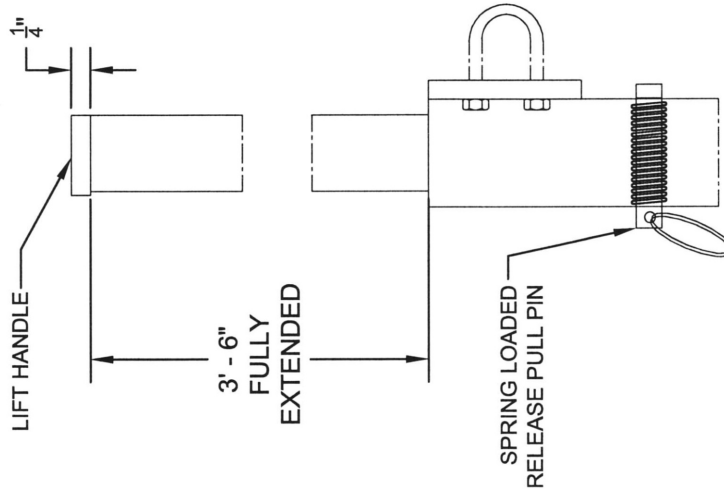
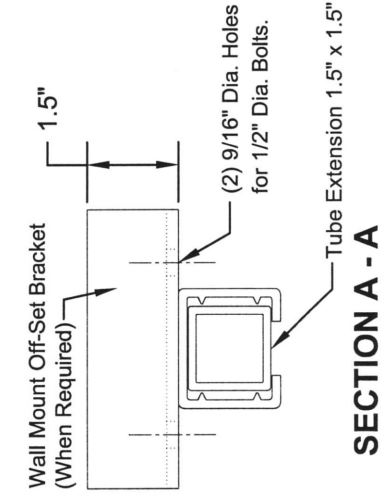
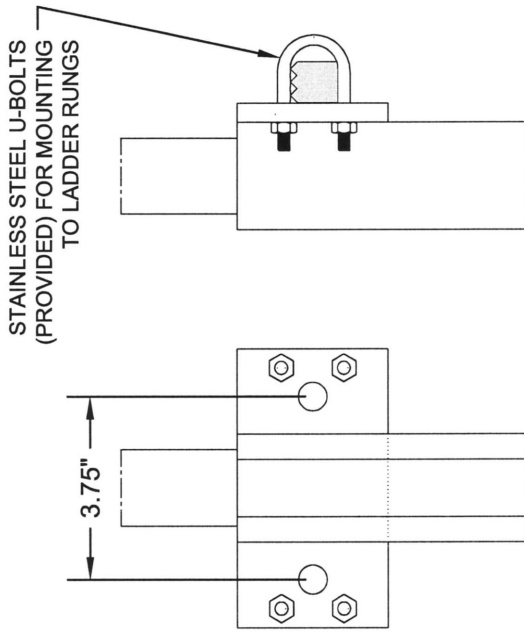
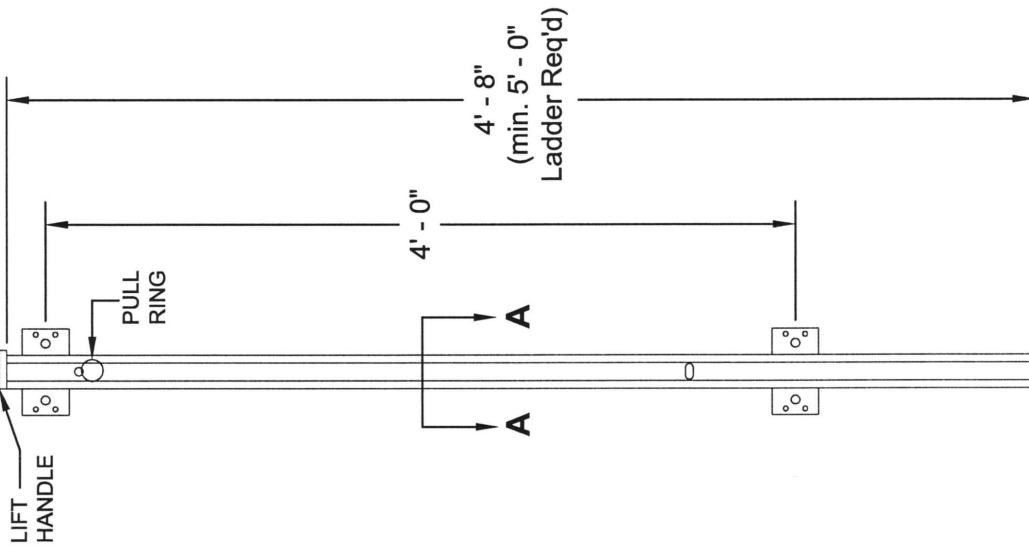

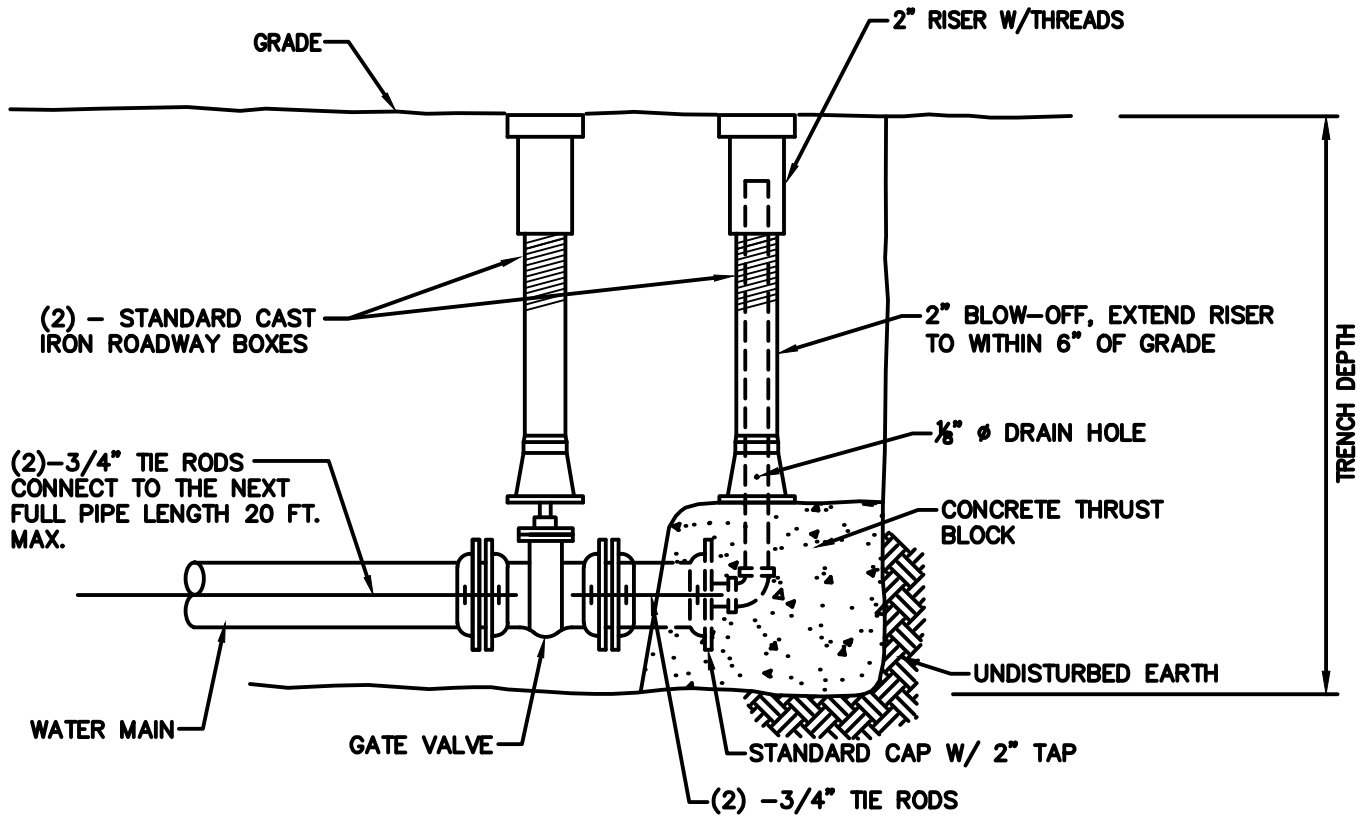

SECTION

CAP AND BLOW-OFF DETAIL

NOT TO SCALE

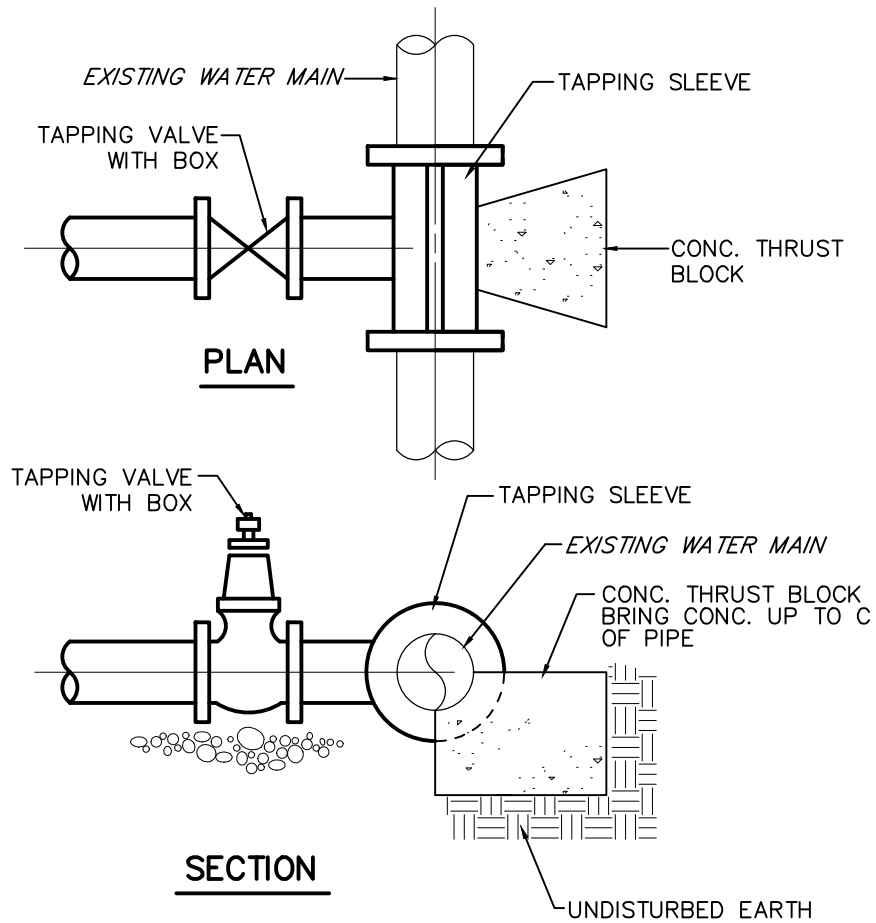
**NOTE:**

1. VALVE BOX TO BE PROVIDED AT ALL TAPPING VALVES.
2. ALL BOLTS SHALL BE WRAPPED IN PLASTIC PRIOR TO POURING CONCRETE THRUST BLOCK.
3. TAPPING VALVE SHALL BE INSTALLED ON 6" BED OF STONE.
4. CENTER VALVE BOX OVER OPERATING NUT TO INSURE FREE VALVE OPERATION.

TAPPING VALVE & SLEEVE

NO SCALE